



Lifting your dreams

GR-130F (I)

〔タワーリーチ式〕

(4段ブーム、6段フルオートジブ、H型アウトリガ)



INDEX

■ 主要諸元	P 1
■ 主要寸法図	P 2
■ 外観図・最小直角通路幅	P 3
■ 作業半径・揚程図 (主巻作業)	P 4
	(補巻作業)	P 5
■ 定格総荷重表 (主巻作業)	P 6
	(補巻作業)	P11

・ブーム長さ、ジブ長さ、アウトリガ張出幅の組合せによって次のように定格総荷重表を選定し該当ページを読み取ってください。

主巻作業				
ジブ アウトリガ張出幅	3.3m			
	5.5m	8.7m	11.8m	15.0m
4.7m	6P	6P	6P	6P
4.3m	7P	7P	7P	7P
3.5m	8P	8P	8P	8P
2.5m	9P	9P	9P	9P
1.64m	10P	10P	10P	10P

補巻作業				
ジブ アウトリガ張出幅	4.1m~15.9m			
	5.5m	8.7m	11.8m	15.0m
4.7m	14P	13P	12P	11P
4.3m	18P	17P	16P	15P
3.5m	22P	21P	20P	19P
2.5m	26P	25P	24P	23P
1.64m	29P	28P	27P	27P

■主要諸元

●クレーン

クレーン容量	主巻作業 3.3mジブ	5.5mブーム	4,900kg × 82° (4本掛)
		8.7mブーム	4,300kg × 80° (4本掛)
		11.8mブーム	4,300kg × 80° (4本掛)
		15.0mブーム	4,300kg × 82° (4本掛)
	補巻作業	4.1mジブ	1,800kg × 70° (1本掛)
		6.5mジブ	1,800kg × 72° (1本掛)
		8.9mジブ	1,200kg × 72° (1本掛)
		13.6mジブ	700kg × 67° (1本掛)
		15.9mジブ	650kg × 78° (1本掛)
最大地上揚程	主巻	19.0m	
	補巻	30.7m	
最大作業半径	主巻	13.0m	
	補巻	23.0m	
ブーム長さ	5.5m~15.0m		
ブーム伸縮長さ	9.5m		
ブーム伸長速度	9.5m/45s		
ジブ長さ	4.1m~15.9m		
ジブ伸縮長さ	11.8m		
ジブ伸長速度	11.8m/30s		
巻き上げ速度 (ローブスピード)	主巻	115m/min(5層)	
	補巻	100m/min(3層)	
フック巻き上げ速度	主巻	28.8m/min(4本掛)	
	補巻	100m/min(1本掛)	
ブーム起伏角度	-3°~82°		
ブーム上げ速度	-3°~82°/40s		
ジブオフセット角度	7°~75°		
ジブ上げ速度	7°~75°/20s		
旋回角度	360°連続		
旋回速度	2.4min ⁻¹ {rpm}		
ワイヤロープ	主巻	径11.2mm × 長さ105m 難燃性ワイヤロープ	
	補巻	径11.2mm × 長さ66m 難燃性ワイヤロープ	
ブーム形式	五角形4段油圧伸縮式(2段目順次、3-4段目同時)		
ブーム伸縮装置	複動油圧シリンダ直押し式2本、ワイヤロープ式伸縮装置1基		
ジブ形式	ブーム横折格納式、五角形6段油圧伸縮式、(2-3段目順次、4-5-6段目同時)		
ジブ伸縮装置	複動油圧シリンダ直押し式3本、ワイヤロープ式伸縮装置2基		
巻き上げ装置	油圧モータ駆動遊星歯車減速式、自動ブレーキ、シングルウインチ 2基、圧力補償付流量調整弁付		
ブーム起伏装置	複動油圧シリンダ直押し式1本、圧力補償付流量調整弁付		
ジブ起伏装置	複動油圧シリンダ直押し式1本、圧力補償付流量調整弁付		
旋回装置	油圧モータ駆動遊星歯車減速式、ボールベアリング式、ネガティブブレーキ		
アウトリガ	全油圧式H型(フロート一体型)、スライド・ジャッキ各個操作装置付、張出幅:最大4.7m、中間4.3m、3.5m、2.5m、最小1.64m		
操作方式	油圧パイロット操作式(フィンガーコントロール式)		
作業時最大路面荷重	10.6t		
動力取出方式	P.T.O.湿式多板クラッチ式		
油圧ポンプ	2連可変ピストンポンプ、2連ギヤポンプ		
安全装置	過負荷防止装置(AML)、旋回自動停止装置、起伏緩停止機能、ジブオフセット緩停止機能、巻過防止装置、作業領域制御装置、アウトリガ張出幅検出装置、水準器、玉掛けロープはずれ止め、油圧安全弁、伸縮シリンダ油圧ロック装置、起伏シリンダ油圧ロック装置、ジブ伸縮シリンダ油圧ロック装置、ジブオフセットシリンダ油圧ロック装置、ジャッキシリンダ油圧ロック装置		
付属装置	除湿機能付エアコン、作動油温度表示灯、FM・AMラジオ、オイルクーラー、視覚式ドラムインジケータ、操作ペダル…ISO配列の場合:伸縮用および補巻用 タダノ配列の場合:起伏用および伸縮用 テレマティクス用通信端末、燃料消費モニター、エコモード、作動油目詰まり警報装置、拡声器、AML外部表示灯		
付属品	盤木(4枚)		

●キャリヤ

車名および型式	タダノ YDR-T015	
エンジン	名称	日野 J05E (過給機及び給気冷却器、DPF/尿素SCRシステム付)
	形式	水冷4サイクル4気筒直接噴射式ディーゼルエンジン
	総排気量	5.123L
	最高出力	129kW{175PS} / 2,500min ⁻¹ {rpm}
	最大トルク	540N·m{55.0kgf·m} / 1,600min ⁻¹ {rpm}
トルクコンバータ形式	3要素1段(自動ロックアップ機構付)	
変速機形式	自動及び手動変速式、パワーシフト式(湿式多板クラッチ)前進3段、後退1段(Hi,Lo付)	
減速機形式	まがり歯かさ歯車2段減速式	
駆動方式	2輪駆動(4×2)・4輪駆動(4×4)切換式	
前車軸方式	全浮動式	
後車軸方式	全浮動式	
懸架方式	前輪	縦置板ばね式
	後輪	縦置板ばね式
ステアリング形式	全油圧式パワーステアリング	
ブレーキ	主ブレーキ	空気油圧複合式ディスクブレーキ
	駐車ブレーキ	機械式推進軸制動内部拡張式
	補助ブレーキ	排気管開閉弁式排気ブレーキ 作業用補助制動装置
フレーム	箱型溶接構造	
バッテリー	12V-100Ah×2個(24V)	
燃料タンク容量	189L	
尿素水タンク容量	19L	
タイヤ	GR-130F-1-00101 前輪・後輪: 275/80R22.5 151/148J	
	GR-130F-1-00102 前輪・後輪: 295/80R22.5 153/150J	
運転室	乗車定員1人、内装付、ゴムマウント方式、フルアジャスタブル・サスペンションシート(ヘッドレスト、アームレスト、シートベルト付)、アジャスト式ハンドル(チルト、伸縮)、間欠式フロント・天井ワイパ(ウォッシュ付)、パワウインド、サイドバイザ	
安全装置	緊急かじ取装置、サスペンションロック装置、リヤステアリングロック装置、エンジンオーバーラン警報装置、オーバシフト防止装置、駐車ブレーキ警報装置、ラジエータ液面警報装置、作動油漏れ警報装置、前方および左前方カメラ	
付属装置	手動式集中給油装置、ヒータ付電動格納ミラー、タイヤ歯止め、LEDヘッドランプ、人物検知警報装置、後方監視カメラ	

●オプション

電動式集中給油装置、路肩灯、マーカーランプ、外部音声警報装置、ハロゲンヘッドランプ、盗難防止装置
--

●走行寸法

	GR-130F-1-00101	GR-130F-1-00102
全長	7,590mm	7,590mm
全幅	2,000mm	2,000mm
全高	2,815mm	2,830mm
軸距	2,750mm	2,750mm
輪距	前輪	1,680mm
	後輪	1,660mm

●走行性能

最高速度	49km/h	
登坂能力(tanθ)	0.36	
最小回転半径	GR-130F-1-00101	GR-130F-1-00102
	3.8m(4輪ステアリング)	4.1m(4輪ステアリング)
	6.5m(2輪ステアリング)	6.8m(2輪ステアリング)

●重量

車両総重量	14,875kg	●最大ジャッキ反力(作業時最大路面荷重)	
前軸重	7,440kg	ブーム	10.6t
後軸重	7,435kg	ジブ	10.3t

■外観図

縮尺 1/100
(単位: mm)

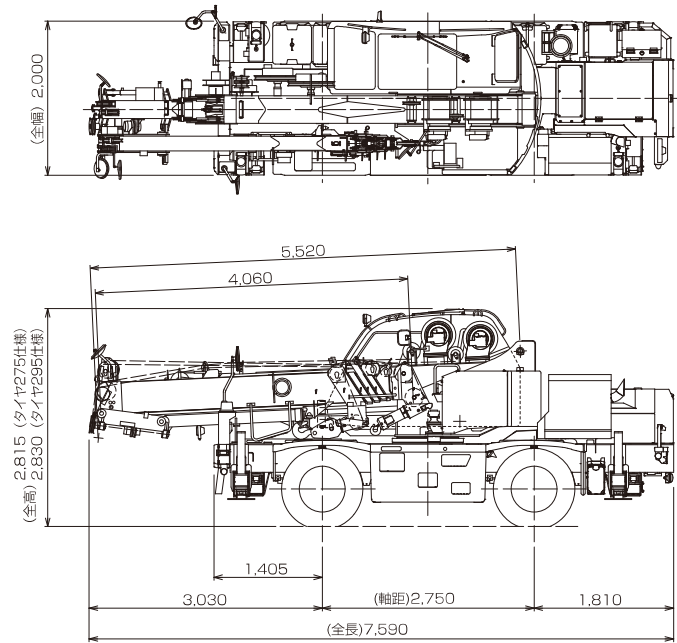

GR-130F-1-00101 : タイヤ275仕様
GR-130F-1-00102 : タイヤ295仕様

■最小直角通路幅

●前2輪ステアリングで右折する場合

		GR-130F-1-	
		00101	00102
(最小回転半径)	R1	6.50m	6.80m
(最外輪端回転半径)	R2	6.64m	6.95m
(車体回転半径)	R3	7.29m	7.85m
(ブーム先端回転半径)	R4	8.15m	8.40m
(入口通路幅)	A	3.55m	3.64m
(車輪出口通路幅)	B	3.55m	3.64m
(車体出口通路幅)	C	4.20m	4.27m
(ブーム先端出口通路幅)	D	5.06m	5.08m

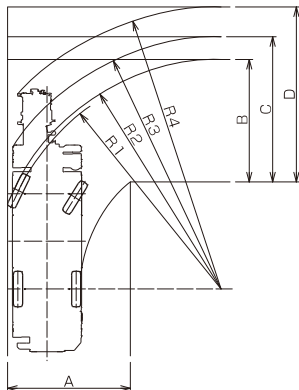

●4輪ステアリングで右折する場合

		GR-130F-1-	
		00101	00102
(最小回転半径)	R1	3.80m	4.10m
(最外輪端回転半径)	R2	3.94m	4.25m
(車体回転半径)	R3	4.68m	4.94m
(ブーム先端回転半径)	R4	5.54m	5.76m
(車輪入口通路幅)	A1	2.43m	2.54m
(車体入口通路幅)	A2	3.42m	3.45m
(車輪出口通路幅)	B	2.43m	2.54m
(車体出口通路幅)	C	3.46m	3.49m
(ブーム先端出口通路幅)	D	4.41m	4.39m

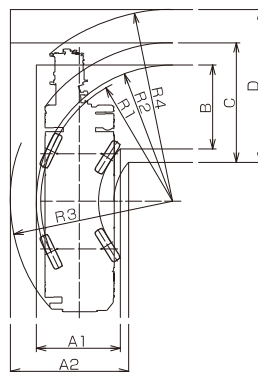

●後2輪ステアリングで右折する場合

		GR-130F-1-	
		00101	00102
(最小回転半径)	R1	6.50m	6.80m
(最外輪端回転半径)	R2	6.64m	6.95m
(車体回転半径)	R3	7.37m	7.65m
(ブーム先端回転半径)	R4	6.55m	6.86m
(車輪入口通路幅)	A1	3.22m	3.33m
(車体入口通路幅)	A2	3.96m	4.02m
(車体出口通路幅)	C	3.98m	4.05m
(ブーム先端出口通路幅)	D	4.36m	4.40m

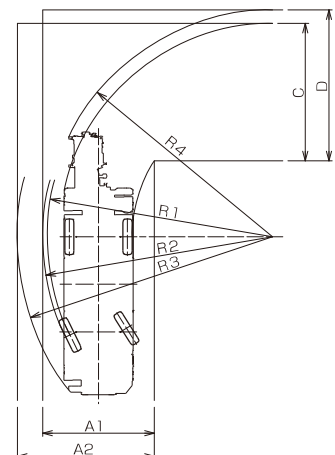

GR-130F-1-00101 : タイヤ275仕様
GR-130F-1-00102 : タイヤ295仕様

(注) 上記数値は計算値です。

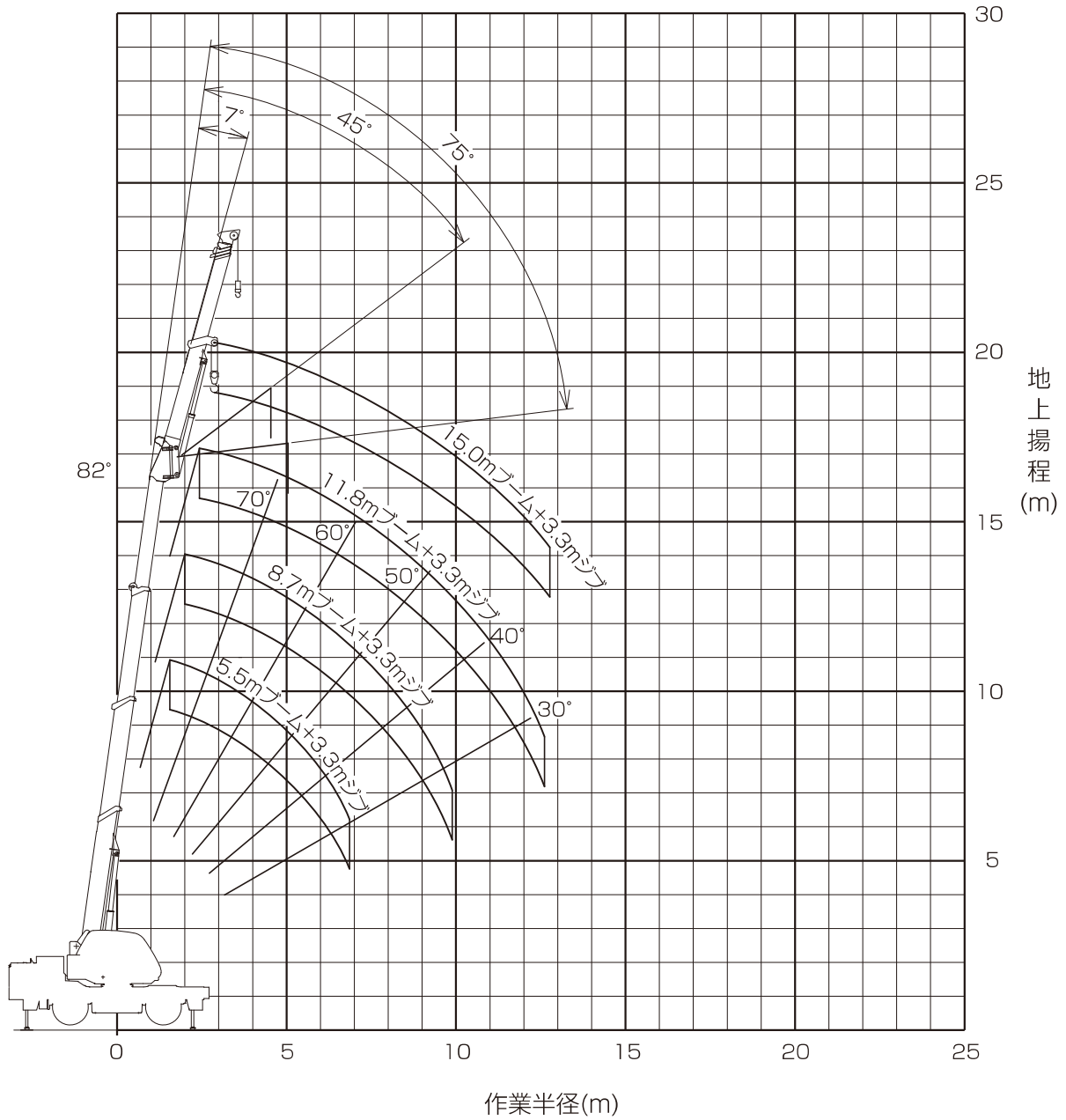

(注) 1.上図はブームのたわみを含んでいません。
2.本図は、アウトリガ最大(4.7m)張出状態での図です。

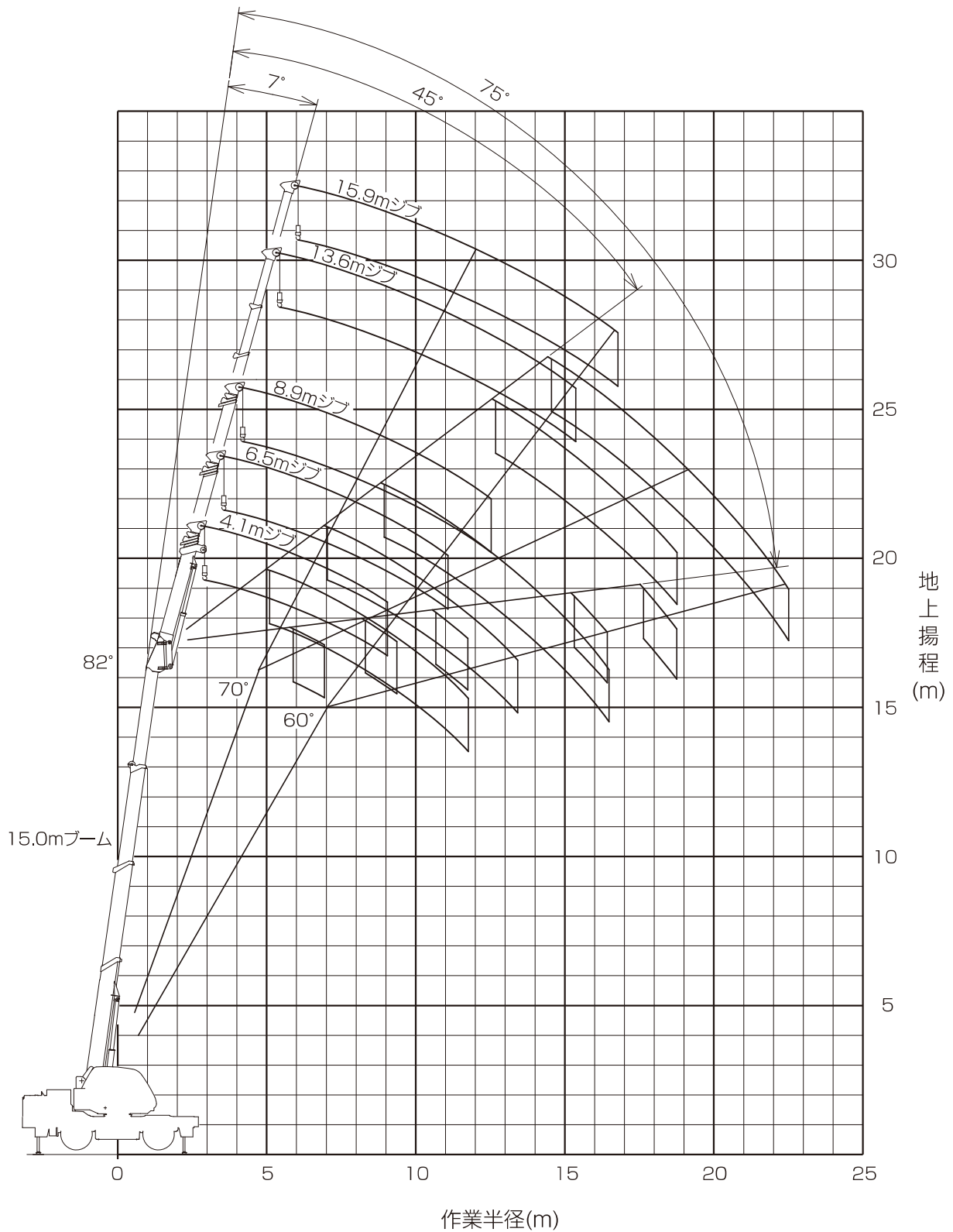

(注) 1.上図はブームのたわみを含んでいません。
 2.本図は、アウトリガ最大(4.7m)張出状態での図です。

5.5mブーム+3.3mジブ												
ジブオフセット	7°		15°		30°		45°		60°		75°	
ブーム角度 (°)	作業半径 (m)	定格総荷重 (t)	作業半径 (m)	定格総荷重 (t)	作業半径 (m)	定格総荷重 (t)	作業半径 (m)	定格総荷重 (t)	作業半径 (m)	定格総荷重 (t)	作業半径 (m)	定格総荷重 (t)
82	1.6	4.30	2.0	4.90	2.7	4.40	3.3	4.30	3.6	3.80	3.7	3.70
80	1.9	4.30	2.3	4.50	3.0	4.40	3.5	4.30	3.8	3.80	3.9	3.70
78	2.2	4.10	2.6	4.10	3.2	4.20	3.7	4.20	4.0	3.80	4.1	3.70
74	2.7	3.35	3.1	3.55	3.7	3.90	4.2	4.05	4.4	3.75		
72	3.0	3.05	3.4	3.35	4.0	3.75	4.4	3.95	4.6	3.70		
70	3.3	2.80	3.6	3.15	4.2	3.60	4.6	3.85	4.8	3.65		
67	3.7	2.50	4.0	2.90	4.6	3.45	4.9	3.75	5.1	3.55		
65	3.9	2.35	4.3	2.75	4.8	3.35	5.1	3.65	5.2	3.45		
62	4.3	2.10	4.6	2.50	5.1	3.20	5.4	3.40	5.5	3.30		
60	4.5	2.00	4.9	2.40	5.3	3.10	5.6	3.30				
57	4.9	1.80	5.2	2.30	5.6	3.00	5.8	3.10				
55	5.1	1.70	5.4	2.20	5.8	2.95	6.0	2.95				
52	5.4	1.55	5.7	2.05	6.1	2.85						
50	5.6	1.50	5.9	2.00	6.2	2.80						
45	6.1	1.35	6.3	1.85	6.6	2.60						
40	6.5	1.25	6.7	1.75	6.9	2.40						
35	6.9	1.15	7.0	1.65	7.1	2.20						
A(°)	7~82		15~82		30~82		45~82		60~82		75~82	

8.7mブーム+3.3mジブ												
ジブオフセット	7°		15°		30°		45°		60°		75°	
ブーム角度 (°)	作業半径 (m)	定格総荷重 (t)	作業半径 (m)	定格総荷重 (t)	作業半径 (m)	定格総荷重 (t)	作業半径 (m)	定格総荷重 (t)	作業半径 (m)	定格総荷重 (t)	作業半径 (m)	定格総荷重 (t)
82	2.1	4.30	2.5	4.30	3.2	4.30	3.7	4.30	4.1	3.80	4.2	3.70
80	2.5	4.30	2.9	4.30	3.6	4.30	4.1	4.30	4.4	3.80	4.5	3.70
78	2.9	3.90	3.3	4.00	3.9	4.05	4.4	4.15	4.7	3.80	4.8	3.70
74	3.6	3.20	4.0	3.45	4.7	3.80	5.1	3.65	5.3	3.45		
72	4.0	2.95	4.4	3.20	5.0	3.65	5.4	3.35	5.6	3.20		
70	4.4	2.75	4.8	3.00	5.4	3.30	5.8	3.10	5.9	3.00		
67	4.9	2.40	5.3	2.80	5.9	2.90	6.2	2.80	6.3	2.75		
65	5.3	2.25	5.6	2.65	6.2	2.70	6.5	2.60	6.6	2.55		
62	5.8	2.00	6.1	2.45	6.6	2.50	6.9	2.35	7.0	2.30		
60	6.2	1.90	6.5	2.35	6.9	2.30	7.2	2.20				
57	6.6	1.75	6.9	2.20	7.4	2.10	7.6	2.00				
55	7.0	1.65	7.2	2.10	7.6	1.95	7.8	1.90				
52	7.4	1.55	7.7	1.90	8.0	1.80	8.2	1.75				
50	7.7	1.45	7.9	1.80	8.3	1.70						
45	8.4	1.35	8.6	1.55	8.9	1.45						
40	9.0	1.20	9.1	1.35	9.3	1.30						
35	9.5	1.10	9.6	1.20	9.8	1.15						
30	9.9	1.00	10.0	1.05	10.1	1.00						
A(°)	7~82		15~82		30~82		45~82		60~82		75~82	

11.8mブーム+3.3mジブ												
ジブオフセット	7°		15°		30°		45°		60°		75°	
ブーム角度 (°)	作業半径 (m)	定格総荷重 (t)	作業半径 (m)	定格総荷重 (t)	作業半径 (m)	定格総荷重 (t)	作業半径 (m)	定格総荷重 (t)	作業半径 (m)	定格総荷重 (t)	作業半径 (m)	定格総荷重 (t)
82	2.6	4.30	3.0	4.30	3.7	4.30	4.3	4.30	4.6	3.80	4.7	3.70
80	3.1	4.30	3.5	4.15	4.2	4.20	4.8	4.00	5.1	3.80	5.1	3.60
78	3.6	3.80	4.0	3.85	4.7	3.95	5.2	3.60	5.5	3.35	5.5	3.35
74	4.6	3.10	5.0	3.35	5.6	3.10	6.1	2.90	6.3	2.75		
72	5.1	2.85	5.5	3.10	6.1	2.80	6.5	2.60	6.7	2.50		
70	5.6	2.60	5.9	2.85	6.5	2.50	6.9	2.40	7.1	2.30		
67	6.3	2.35	6.6	2.40	7.2	2.20	7.6	2.05	7.7	2.00		
65	6.7	2.20	7.1	2.20	7.6	2.00	7.9	1.85	8.0	1.85		
62	7.4	1.95	7.7	1.90	8.2	1.75	8.5	1.65				
60	7.8	1.80	8.1	1.75	8.6	1.65	8.9	1.55				
57	8.4	1.60	8.7	1.50	9.2	1.45	9.4	1.35				
55	8.8	1.45	9.1	1.40	9.5	1.30	9.7	1.25				
52	9.4	1.25	9.7	1.20	10.1	1.10	10.2	1.05				
50	9.8	1.15	10.0	1.10	10.4	1.00	10.5	0.95				
45	10.7	0.85	10.9	0.80	11.2	0.70	11.2	0.70				
40	11.4	0.60	11.6	0.55	11.8	0.50						
35	12.1	0.45	12.3	0.40								
30	12.7	0.30	12.8	0.25								
A(°)	25~82		30~82		45~82		60~82		75~82		75~82	

15.0mブーム+3.3mジブ												
ジブオフセット	7°		15°		30°		45°		60°		75°	
ブーム角度 (°)	作業半径 (m)	定格総荷重 (t)	作業半径 (m)	定格総荷重 (t)	作業半径 (m)	定格総荷重 (t)	作業半径 (m)	定格総荷重 (t)	作業半径 (m)	定格総荷重 (t)	作業半径 (m)	定格総荷重 (t)
82	3.2	4.30	3.6	4.20	4.4	3.90	4.9	3.30	5.2	3.20	5.3	3.20
80	3.8	4.05	4.3	4.05	5.0	3.60	5.5	3.30	5.8	3.05	5.8	3.05
78	4.4	3.65	4.9	3.70	5.5	3.25	6.0	2.95	6.3	2.75		
74	5.6	3.00	6.0	2.80	6.7	2.50	7.1	2.30	7.3	2.20		
72	6.2	2.60	6.6	2.45	7.2	2.20	7.7	2.05	7.8	1.95		
70	6.8	2.30	7.2	2.15	7.8	1.95	8.2	1.85	8.3	1.80		
67	7.7	1.90	8.0	1.80	8.6	1.65	8.9	1.50	9.1	1.50		
65	8.2	1.70	8.6	1.60	9.1	1.45	9.4	1.35	9.5	1.35		
62	9.0	1.45	9.4	1.35	9.9	1.20	10.1	1.15	10.2	1.15		
60	9.5	1.25	9.9	1.20	10.4	1.05	10.6	0.95				
57	10.3	1.00	10.6	0.95	11.1	0.80	11.3	0.70				
55	10.8	0.80	11.1	0.75	11.5	0.65	11.7	0.60				
52	11.5	0.60	11.8	0.55	12.2	0.45	12.3	0.40				
50	12.0	0.45	12.2	0.40	12.6	0.30	12.7	0.30				
45	13.0	0.20										
A(°)	40~82		45~82		60~82		75~82		75~82		75~82	

■ 定格総荷重表 [主巻作業] アウトリガ中間張出 (4.3m) -側方-

主巻作業

5.5mブーム+3.3mジブ												
ジブオフセット	7°		15°		30°		45°		60°		75°	
ブーム角度 (°)	作業半径 (m)	定格総荷重 (t)	作業半径 (m)	定格総荷重 (t)	作業半径 (m)	定格総荷重 (t)	作業半径 (m)	定格総荷重 (t)	作業半径 (m)	定格総荷重 (t)	作業半径 (m)	定格総荷重 (t)
82	1.6	4.30	2.0	4.90	2.7	4.40	3.3	4.30	3.6	3.80	3.7	3.70
80	1.9	4.30	2.3	4.50	3.0	4.40	3.5	4.30	3.8	3.80	3.9	3.70
78	2.2	4.10	2.6	4.10	3.2	4.20	3.7	4.20	4.0	3.80	4.1	3.70
74	2.7	3.35	3.1	3.55	3.7	3.90	4.2	4.05	4.4	3.70		
72	3.0	3.05	3.4	3.35	4.0	3.75	4.4	3.95	4.6	3.70		
70	3.3	2.80	3.6	3.15	4.2	3.60	4.6	3.85	4.8	3.65		
67	3.7	2.50	4.0	2.90	4.6	3.45	4.9	3.75	5.1	3.55		
65	3.9	2.35	4.3	2.75	4.8	3.35	5.1	3.65	5.2	3.45		
62	4.3	2.10	4.6	2.50	5.1	3.20	5.4	3.40	5.5	3.30		
60	4.5	2.00	4.9	2.40	5.3	3.10	5.6	3.30				
57	4.9	1.80	5.2	2.30	5.6	3.00	5.8	3.10				
55	5.1	1.70	5.4	2.20	5.8	2.95	6.0	2.95				
52	5.4	1.55	5.7	2.05	6.1	2.85						
50	5.6	1.50	5.9	2.00	6.2	2.80						
45	6.1	1.35	6.3	1.85	6.6	2.60						
40	6.5	1.25	6.7	1.75	6.9	2.40						
35	6.9	1.15	7.0	1.65	7.1	2.20						
A(°)	7~82		15~82		30~82		45~82		60~82		75~82	

8.7mブーム+3.3mジブ												
ジブオフセット	7°		15°		30°		45°		60°		75°	
ブーム角度 (°)	作業半径 (m)	定格総荷重 (t)	作業半径 (m)	定格総荷重 (t)	作業半径 (m)	定格総荷重 (t)	作業半径 (m)	定格総荷重 (t)	作業半径 (m)	定格総荷重 (t)	作業半径 (m)	定格総荷重 (t)
82	2.1	4.30	2.5	4.30	3.2	4.30	3.7	4.30	4.1	3.80	4.2	3.70
80	2.5	4.30	2.9	4.30	3.6	4.30	4.1	4.30	4.4	3.80	4.5	3.70
78	2.9	3.90	3.3	4.00	3.9	4.05	4.4	4.15	4.7	3.80	4.8	3.70
74	3.6	3.20	4.0	3.45	4.7	3.80	5.1	3.65	5.3	3.45		
72	4.0	2.95	4.4	3.20	5.0	3.65	5.4	3.35	5.6	3.20		
70	4.4	2.75	4.8	3.00	5.4	3.30	5.8	3.10	5.9	3.00		
67	4.9	2.40	5.3	2.80	5.9	2.90	6.2	2.80	6.3	2.75		
65	5.3	2.25	5.6	2.65	6.2	2.70	6.5	2.60	6.6	2.55		
62	5.8	2.00	6.1	2.45	6.6	2.50	6.9	2.35	7.0	2.30		
60	6.2	1.90	6.5	2.35	6.9	2.30	7.2	2.20				
57	6.6	1.75	6.9	2.20	7.4	2.10	7.6	2.00				
55	7.0	1.65	7.2	2.10	7.6	1.95	7.8	1.90				
52	7.4	1.55	7.7	1.90	8.0	1.80	8.2	1.75				
50	7.7	1.45	7.9	1.80	8.3	1.70						
45	8.4	1.35	8.6	1.55	8.9	1.45						
40	9.0	1.20	9.1	1.35	9.3	1.25						
35	9.5	1.10	9.6	1.20	9.8	1.05						
30	9.9	1.00	10.0	0.95	10.1	0.90						
A(°)	7~82		15~82		30~82		45~82		60~82		75~82	

11.8mブーム+3.3mジブ												
ジブオフセット	7°		15°		30°		45°		60°		75°	
ブーム角度 (°)	作業半径 (m)	定格総荷重 (t)	作業半径 (m)	定格総荷重 (t)	作業半径 (m)	定格総荷重 (t)	作業半径 (m)	定格総荷重 (t)	作業半径 (m)	定格総荷重 (t)	作業半径 (m)	定格総荷重 (t)
82	2.6	4.30	3.0	4.30	3.7	4.30	4.3	4.30	4.6	3.80	4.7	3.70
80	3.1	4.30	3.5	4.15	4.2	4.20	4.8	4.00	5.1	3.80	5.1	3.60
78	3.6	3.80	4.0	3.85	4.7	3.95	5.2	3.60	5.5	3.35	5.5	3.35
74	4.6	3.10	5.0	3.35	5.6	3.10	6.1	2.90	6.3	2.75		
72	5.1	2.85	5.5	3.10	6.1	2.80	6.5	2.60	6.7	2.50		
70	5.6	2.60	5.9	2.85	6.5	2.50	6.9	2.40	7.1	2.30		
67	6.3	2.35	6.6	2.40	7.2	2.20	7.6	2.05	7.7	2.00		
65	6.7	2.20	7.1	2.20	7.6	2.00	7.9	1.85	8.0	1.85		
62	7.4	1.95	7.7	1.90	8.2	1.75	8.5	1.65				
60	7.8	1.80	8.1	1.75	8.6	1.65	8.9	1.55				
57	8.4	1.60	8.7	1.50	9.2	1.45	9.4	1.30				
55	8.8	1.45	9.1	1.40	9.5	1.25	9.7	1.15				
52	9.4	1.25	9.7	1.15	10.1	1.00	10.2	0.95				
50	9.8	1.10	10.0	1.05	10.4	0.90	10.5	0.85				
45	10.7	0.75	10.9	0.70	11.2	0.60	11.2	0.60				
40	11.4	0.50	11.6	0.45	11.8	0.40						
A(°)	30~82		35~82		45~82		60~82		75~82			

15.0mブーム+3.3mジブ												
ジブオフセット	7°		15°		30°		45°		60°		75°	
ブーム角度 (°)	作業半径 (m)	定格総荷重 (t)	作業半径 (m)	定格総荷重 (t)	作業半径 (m)	定格総荷重 (t)	作業半径 (m)	定格総荷重 (t)	作業半径 (m)	定格総荷重 (t)	作業半径 (m)	定格総荷重 (t)
82	3.2	4.30	3.6	4.20	4.4	3.90	4.9	3.30	5.2	3.20	5.3	3.20
80	3.8	4.05	4.3	4.05	5.0	3.60	5.5	3.30	5.8	3.05	5.8	3.05
78	4.4	3.65	4.9	3.70	5.5	3.25	6.0	2.95	6.3	2.75		
74	5.6	3.00	6.0	2.80	6.7	2.50	7.1	2.30	7.3	2.20		
72	6.2	2.60	6.6	2.45	7.2	2.20	7.7	2.05	7.8	1.95		
70	6.8	2.30	7.2	2.15	7.8	1.95	8.2	1.85	8.3	1.80		
67	7.7	1.90	8.0	1.80	8.6	1.65	8.9	1.50	9.1	1.50		
65	8.2	1.70	8.6	1.60	9.1	1.45	9.4	1.35	9.5	1.30		
62	9.0	1.45	9.4	1.30	9.9	1.15	10.1	1.05	10.2	1.05		
60	9.5	1.25	9.9	1.10	10.4	0.95	10.6	0.85				
57	10.3	0.95	10.6	0.85	11.1	0.65	11.3	0.60				
55	10.8	0.70	11.1	0.65	11.5	0.55	11.7	0.50				
52	11.5	0.50	11.8	0.45								
50	12.0	0.35										
A(°)	45~82		50~82		52~82		60~82		75~82			

A: ブーム角度の範囲 (無負荷時)

5.5mブーム+3.3mジブ												
ジブオフセット	7°		15°		30°		45°		60°		75°	
ブーム角度 (°)	作業半径 (m)	定格総荷重 (t)	作業半径 (m)	定格総荷重 (t)	作業半径 (m)	定格総荷重 (t)	作業半径 (m)	定格総荷重 (t)	作業半径 (m)	定格総荷重 (t)	作業半径 (m)	定格総荷重 (t)
82	1.6	4.30	2.0	4.90	2.7	4.40	3.3	4.30	3.6	3.80	3.7	3.70
80	1.9	4.30	2.3	4.50	3.0	4.40	3.5	4.30	3.8	3.80	3.9	3.70
78	2.2	4.10	2.6	4.10	3.2	4.20	3.7	4.20	4.0	3.80	4.1	3.70
74	2.7	3.35	3.1	3.55	3.7	3.90	4.2	4.05	4.4	3.75		
72	3.0	3.05	3.4	3.35	4.0	3.75	4.4	3.95	4.6	3.70		
70	3.3	2.80	3.6	3.15	4.2	3.60	4.6	3.85	4.8	3.65		
67	3.7	2.50	4.0	2.90	4.6	3.45	4.9	3.75	5.1	3.55		
65	3.9	2.35	4.3	2.75	4.8	3.35	5.1	3.65	5.2	3.45		
62	4.3	2.10	4.6	2.50	5.1	3.20	5.4	3.40	5.5	3.30		
60	4.5	2.00	4.9	2.40	5.3	3.10	5.6	3.20				
57	4.9	1.80	5.2	2.30	5.6	2.95	5.8	2.90				
55	5.1	1.70	5.4	2.20	5.8	2.85	6.0	2.70				
52	5.4	1.55	5.7	2.05	6.1	2.65						
50	5.6	1.50	5.9	2.00	6.2	2.55						
45	6.1	1.35	6.3	1.85	6.6	2.20						
40	6.5	1.25	6.7	1.75	6.9	1.90						
35	6.9	1.15	7.0	1.65	7.1	1.70						
A(°)	7~82		15~82		30~82		45~82		60~82		75~82	

8.7mブーム+3.3mジブ												
ジブオフセット	7°		15°		30°		45°		60°		75°	
ブーム角度 (°)	作業半径 (m)	定格総荷重 (t)	作業半径 (m)	定格総荷重 (t)	作業半径 (m)	定格総荷重 (t)	作業半径 (m)	定格総荷重 (t)	作業半径 (m)	定格総荷重 (t)	作業半径 (m)	定格総荷重 (t)
82	2.1	4.30	2.5	4.30	3.2	4.30	3.7	4.30	4.1	3.80	4.2	3.70
80	2.5	4.30	2.9	4.30	3.6	4.30	4.1	4.30	4.4	3.80	4.5	3.70
78	2.9	3.90	3.3	4.00	3.9	4.05	4.4	4.15	4.7	3.80	4.8	3.70
74	3.6	3.20	4.0	3.45	4.7	3.80	5.1	3.65	5.3	3.40		
72	4.0	2.95	4.4	3.20	5.0	3.65	5.4	3.30	5.6	3.10		
70	4.4	2.75	4.8	3.00	5.4	3.30	5.8	2.90	5.9	2.75		
67	4.9	2.40	5.3	2.80	5.9	2.70	6.2	2.40	6.3	2.35		
65	5.3	2.25	5.6	2.65	6.2	2.40	6.5	2.20	6.6	2.10		
62	5.8	2.00	6.1	2.40	6.6	2.00	6.9	1.80	7.0	1.75		
60	6.2	1.90	6.5	2.10	6.9	1.75	7.2	1.60				
57	6.6	1.75	6.9	1.70	7.4	1.50	7.6	1.35				
55	7.0	1.65	7.2	1.50	7.6	1.30	7.8	1.20				
52	7.4	1.45	7.7	1.30	8.0	1.10	8.2	1.00				
50	7.7	1.30	7.9	1.10	8.3	1.00						
45	8.4	0.95	8.6	0.85	8.9	0.70						
40	9.0	0.65	9.1	0.60	9.3	0.52						
35	9.5	0.45	9.6	0.40	9.8	0.36						
30	9.9	0.25	10.0	0.25	10.1	0.22						
A(°)	25~82				30~82		45~82		60~82		75~82	

11.8mブーム+3.3mジブ												
ジブオフセット	7°		15°		30°		45°		60°		75°	
ブーム角度 (°)	作業半径 (m)	定格総荷重 (t)	作業半径 (m)	定格総荷重 (t)	作業半径 (m)	定格総荷重 (t)	作業半径 (m)	定格総荷重 (t)	作業半径 (m)	定格総荷重 (t)	作業半径 (m)	定格総荷重 (t)
82	2.6	4.30	3.0	4.30	3.7	4.30	4.3	4.30	4.6	3.80	4.7	3.70
80	3.1	4.30	3.5	4.15	4.2	4.20	4.8	4.00	5.1	3.80	5.1	3.60
78	3.6	3.80	4.0	3.85	4.7	3.95	5.2	3.60	5.5	3.30	5.5	3.25
74	4.6	3.10	5.0	3.35	5.6	3.05	6.1	2.60	6.3	2.40		
72	5.1	2.85	5.5	3.10	6.1	2.55	6.5	2.25	6.7	2.10		
70	5.6	2.60	5.9	2.65	6.5	2.15	6.9	1.90	7.1	1.80		
67	6.3	2.20	6.6	2.05	7.2	1.70	7.6	1.50	7.7	1.45		
65	6.7	1.90	7.1	1.65	7.6	1.45	7.9	1.30	8.0	1.25		
62	7.4	1.45	7.7	1.30	8.2	1.10	8.5	1.00				
60	7.8	1.20	8.1	1.10	8.6	0.90	8.9	0.85				
57	8.4	0.90	8.7	0.80	9.2	0.70	9.4	0.65				
55	8.8	0.75	9.1	0.65	9.5	0.55	9.7	0.50				
52	9.4	0.55	9.7	0.45	10.1	0.35						
50	9.8	0.40	10.0	0.35								
A(°)	45~82				50~82		52~82		60~82		75~82	

15.0mブーム+3.3mジブ												
ジブオフセット	7°		15°		30°		45°		60°		75°	
ブーム角度 (°)	作業半径 (m)	定格総荷重 (t)	作業半径 (m)	定格総荷重 (t)	作業半径 (m)	定格総荷重 (t)	作業半径 (m)	定格総荷重 (t)	作業半径 (m)	定格総荷重 (t)	作業半径 (m)	定格総荷重 (t)
82	3.2	4.30	3.6	4.20	4.4	3.90	4.9	3.30	5.2	3.20	5.3	3.20
80	3.8	4.05	4.3	4.05	5.0	3.60	5.5	3.30	5.8	2.95	5.8	2.85
78	4.4	3.65	4.9	3.70	5.5	3.25	6.0	2.70	6.3	2.45		
74	5.6	2.95	6.0	2.55	6.7	2.05	7.1	1.75	7.3	1.65		
72	6.2	2.30	6.6	2.00	7.2	1.65	7.7	1.45	7.8	1.35		
70	6.8	1.85	7.2	1.60	7.8	1.35	8.2	1.15	8.3	1.10		
67	7.7	1.35	8.0	1.15	8.6	1.00	8.9	0.85	9.1	0.80		
65	8.2	1.05	8.6	0.90	9.1	0.75	9.4	0.65	9.5	0.60		
62	9.0	0.70	9.4	0.60	9.9	0.50						
60	9.5	0.50	9.9	0.45								
A(°)	57~82				60~82		62~82				75~82	

A: ブーム角度の範囲 (無負荷時)

5.5mブーム+3.3mジブ												
ジブオフセット	7°		15°		30°		45°		60°		75°	
ブーム角度 (°)	作業半径 (m)	定格総荷重 (t)	作業半径 (m)	定格総荷重 (t)	作業半径 (m)	定格総荷重 (t)	作業半径 (m)	定格総荷重 (t)	作業半径 (m)	定格総荷重 (t)	作業半径 (m)	定格総荷重 (t)
82	1.6	4.30	2.0	4.90	2.7	4.40	3.3	4.30	3.6	3.50	3.7	3.50
80	1.9	4.30	2.3	4.50	3.0	4.40	3.5	4.30	3.8	3.50	3.9	3.50
78	2.2	4.10	2.6	4.10	3.2	4.20	3.7	3.90	4.0	3.50	4.1	3.30
74	2.7	3.35	3.1	3.55	3.7	3.75	4.2	3.10	4.4	2.75		
72	3.0	3.05	3.4	3.35	4.0	3.40	4.4	2.75	4.6	2.50		
70	3.3	2.80	3.6	3.15	4.2	3.05	4.6	2.45	4.8	2.30		
67	3.7	2.50	4.0	2.90	4.6	2.50	4.9	2.10	5.1	2.00		
65	3.9	2.35	4.3	2.70	4.8	2.25	5.1	1.95	5.2	1.80		
62	4.3	2.10	4.6	2.40	5.1	1.95	5.4	1.70	5.5	1.55		
60	4.5	2.00	4.9	2.10	5.3	1.75	5.6	1.55				
57	4.9	1.80	5.2	1.80	5.6	1.50	5.8	1.30				
55	5.1	1.70	5.4	1.60	5.8	1.35	6.0	1.20				
52	5.4	1.55	5.7	1.35	6.1	1.20						
50	5.6	1.40	5.9	1.20	6.2	1.10						
45	6.1	1.10	6.3	1.00	6.6	0.90						
40	6.5	0.90	6.7	0.80	6.9	0.70						
35	6.9	0.70	7.0	0.65								
A(°)	30~82				35~82		45~82		60~82		75~82	

8.7mブーム+3.3mジブ												
ジブオフセット	7°		15°		30°		45°		60°		75°	
ブーム角度 (°)	作業半径 (m)	定格総荷重 (t)	作業半径 (m)	定格総荷重 (t)	作業半径 (m)	定格総荷重 (t)	作業半径 (m)	定格総荷重 (t)	作業半径 (m)	定格総荷重 (t)	作業半径 (m)	定格総荷重 (t)
82	2.1	4.30	2.5	4.30	3.2	4.30	3.7	3.40	4.1	2.60	4.2	2.60
80	2.5	4.30	2.9	4.30	3.6	4.30	4.1	3.40	4.4	2.60	4.5	2.60
78	2.9	3.90	3.3	4.00	3.9	3.35	4.4	2.65	4.7	2.35	4.8	2.25
74	3.6	3.20	4.0	3.10	4.7	2.30	5.1	1.90	5.3	1.65		
72	4.0	2.95	4.4	2.50	5.0	1.90	5.4	1.55	5.6	1.40		
70	4.4	2.45	4.8	2.05	5.4	1.60	5.8	1.30	5.9	1.20		
67	4.9	1.80	5.3	1.55	5.9	1.20	6.2	1.05	6.3	0.95		
65	5.3	1.50	5.6	1.30	6.2	1.00	6.5	0.85	6.6	0.80		
62	5.8	1.15	6.1	1.00	6.6	0.75	6.9	0.65	7.0	0.60		
60	6.2	0.95	6.5	0.80	6.9	0.60	7.2	0.50				
57	6.6	0.70	6.9	0.50								
55	7.0	0.50	7.2	0.40								
A(°)	45~82				52~82				60~82		75~82	

11.8mブーム+3.3mジブ												
ジブオフセット	7°		15°		30°		45°		60°		75°	
ブーム角度 (°)	作業半径 (m)	定格総荷重 (t)	作業半径 (m)	定格総荷重 (t)	作業半径 (m)	定格総荷重 (t)	作業半径 (m)	定格総荷重 (t)	作業半径 (m)	定格総荷重 (t)	作業半径 (m)	定格総荷重 (t)
82	2.6	4.30	3.0	4.30	3.7	3.30	4.3	2.60	4.6	2.05	4.7	2.05
80	3.1	4.30	3.5	4.15	4.2	3.00	4.8	2.30	5.1	2.05	5.1	1.90
78	3.6	3.70	4.0	3.10	4.7	2.30	5.2	1.85	5.5	1.65	5.5	1.55
74	4.6	2.20	5.0	1.85	5.6	1.40	6.1	1.15	6.3	1.05		
72	5.1	1.70	5.5	1.40	6.1	1.10	6.5	0.95	6.7	0.85		
70	5.6	1.30	5.9	1.15	6.5	0.85	6.9	0.70	7.1	0.60		
67	6.3	0.90	6.6	0.80	7.2	0.50	7.6	0.40	7.7	0.35		
65	6.7	0.70	7.1	0.60	7.6	0.35	7.9	0.20	8.0	0.20		
A(°)	60~82				62~82				75~82			

15.0mブーム+3.3mジブ												
ジブオフセット	7°		15°		30°		45°		60°		75°	
ブーム角度 (°)	作業半径 (m)	定格総荷重 (t)	作業半径 (m)	定格総荷重 (t)	作業半径 (m)	定格総荷重 (t)	作業半径 (m)	定格総荷重 (t)	作業半径 (m)	定格総荷重 (t)	作業半径 (m)	定格総荷重 (t)
82	3.2	4.00	3.6	3.15	4.4	2.50	4.9	1.55	5.2	1.60	5.3	1.60
80	3.8	3.35	4.3	2.75	5.0	1.95	5.5	1.55	5.8	1.40	5.8	1.35
78	4.4	2.40	4.9	2.00	5.5	1.50	6.0	1.20	6.3	1.10		
74	5.6	1.30	6.0	1.10	6.7	0.80	7.1	0.65				
72	6.2	0.90	6.6	0.75	7.2	0.55						
70	6.8	0.60	7.2	0.50								
A(°)	67~82				70~82				75~82			

A: ブーム角度の範囲 (無負荷時)

■ 定格総荷重表 [主巻作業] アウトリガ最小張出 (1.64m) -側方-

主巻作業

5.5mブーム+3.3mジブ													
ジブオフセット	7°		15°		30°		45°		60°		75°		
ブーム角度 (°)	作業半径 (m)	定格総荷重 (t)	作業半径 (m)	定格総荷重 (t)	作業半径 (m)	定格総荷重 (t)	作業半径 (m)	定格総荷重 (t)	作業半径 (m)	定格総荷重 (t)	作業半径 (m)	定格総荷重 (t)	
82	1.6	4.30	2.0	4.90	2.7	2.80	3.3	2.10	3.6	1.50	3.7	1.50	
80	1.9	4.30	2.3	4.30	3.0	2.80	3.5	2.10	3.8	1.50	3.9	1.50	
78	2.2	4.10	2.6	3.60	3.2	2.40	3.7	1.90	4.0	1.50	4.1	1.50	
74	2.7	3.20	3.1	2.50	3.7	1.80	4.2	1.30	4.4	1.10			
72	3.0	2.60	3.4	2.10	4.0	1.40	4.4	1.10	4.6	0.95			
70	3.3	2.20	3.6	1.70	4.2	1.20	4.6	1.00	4.8	0.80			
67	3.7	1.60	4.0	1.30	4.6	0.90	4.9	0.75	5.1	0.60			
65	3.9	1.20	4.3	1.10	4.8	0.80	5.1	0.60	5.2	0.50			
62	4.3	0.95	4.6	0.85	5.1	0.60	5.4	0.45	5.5	0.35			
60	4.5	0.85	4.9	0.70	5.3	0.45	5.6	0.30					
A(°)	55~82		57~82				60~82		75~82				

8.7mブーム+3.3mジブ													
ジブオフセット	7°		15°		30°		45°		60°		75°		
ブーム角度 (°)	作業半径 (m)	定格総荷重 (t)	作業半径 (m)	定格総荷重 (t)	作業半径 (m)	定格総荷重 (t)	作業半径 (m)	定格総荷重 (t)	作業半径 (m)	定格総荷重 (t)	作業半径 (m)	定格総荷重 (t)	
82	2.1	3.50	2.5	2.50	3.2	1.85	3.7	1.40	4.1	1.00	4.2	1.00	
80	2.5	3.50	2.9	2.50	3.6	1.85	4.1	1.40	4.4	1.00	4.5	1.00	
78	2.9	2.80	3.3	2.20	3.9	1.70	4.4	1.00	4.7	0.85	4.8	0.80	
74	3.6	1.50	4.0	1.15	4.7	0.75	5.1	0.55	5.3	0.45			
72	4.0	1.10	4.4	0.85	5.0	0.50	5.4	0.35					
70	4.4	0.80	4.8	0.60									
A(°)	65~82		67~82				70~82		72~82		75~82		

11.8mブーム+3.3mジブ													
ジブオフセット	7°		15°		30°		45°		60°		75°		
ブーム角度 (°)	作業半径 (m)	定格総荷重 (t)	作業半径 (m)	定格総荷重 (t)	作業半径 (m)	定格総荷重 (t)	作業半径 (m)	定格総荷重 (t)	作業半径 (m)	定格総荷重 (t)	作業半径 (m)	定格総荷重 (t)	
82	2.6	2.40	3.0	1.75	3.7	1.35	4.3	0.95	4.6	0.65	4.7	0.65	
80	3.1	2.40	3.5	1.75	4.2	1.20	4.8	0.80	5.1	0.65	5.1	0.60	
78	3.6	1.60	4.0	1.20	4.7	0.80	5.2	0.50	5.5	0.40	5.5	0.40	
74	4.6	0.60	5.0	0.45									
A(°)	70~82		72~82				74~82		75~82				

15.0mブーム+3.3mジブ												
ジブオフセット	7°		15°		30°		45°		60°		75°	
ブーム角度 (°)	作業半径 (m)	定格総荷重 (t)	作業半径 (m)	定格総荷重 (t)	作業半径 (m)	定格総荷重 (t)	作業半径 (m)	定格総荷重 (t)	作業半径 (m)	定格総荷重 (t)	作業半径 (m)	定格総荷重 (t)
82	3.2	1.70	3.6	1.20	4.4	0.90						
80	3.8	1.40	4.3	1.00	5.0	0.60						
78	4.4	0.80	4.9	0.60								
A(°)	74~82				78~82							

A: ブーム角度の範囲 (無負荷時)

(注意)

1. 定格総荷重は、水平堅土上においてクレーンを水平に設置した状態での値で、つり具と主巻フック質量 (75kg) を含んだ値です。太線より上はクレーンの強度によって定められ、下はクレーンの安定度によって定められています。
2. ブームの角度を基準にしてください。なお、作業半径は、ブームのたわみを含んだ参考値を示します。
3. 主巻作業時は、補巻フックが主巻フックと干渉しない程度にジブ長さを4.1m~6.5mの間で調整してください。
4. 主巻作業におけるフックのワイヤロープ標準巻掛本数は4本です。
5. 側方域でのつり上げ性能は、アウトリガ張出幅によって異なります。張出幅に応じた性能で作業をしてください。また、前方・後方域でのつり上げ性能は「アウトリガ最大張出」の定格総荷重ですが、アウトリガ張出幅によってその前方・後方域の範囲(角度 a)が異なります。

張出幅	中間張出 (4.3m)	中間張出 (3.5m)	中間張出 (2.5m)	最小張出 (1.64m)
角度 a°	35	25	15	5

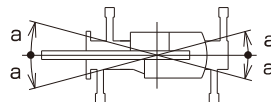

15.0mブーム+4.1mジブ												
ジブオフセット	※7°		※15°		30°		45°		60°		75°	
ブーム角度 (°)	作業半径 (m)	定格総荷重 (t)	作業半径 (m)	定格総荷重 (t)	作業半径 (m)	定格総荷重 (t)	作業半径 (m)	定格総荷重 (t)	作業半径 (m)	定格総荷重 (t)	作業半径 (m)	定格総荷重 (t)
82	3.3	1.80	4.0	1.80	4.6	1.80	5.4	1.80	5.9	1.80	6.1	1.80
80	4.0	1.80	4.7	1.80	5.3	1.80	6.0	1.80	6.4	1.80	6.6	1.80
78	4.8	1.80	5.3	1.80	5.9	1.80	6.6	1.80	7.0	1.80	7.1	1.80
74	6.1	1.80	6.7	1.80	7.1	1.80	7.7	1.80	8.1	1.80		
72	6.8	1.80	7.4	1.80	7.7	1.80	8.2	1.80	8.6	1.70		
70	7.5	1.75	8.0	1.75	8.2	1.80	8.8	1.70	9.1	1.60		
67	8.4	1.65	8.9	1.55	9.1	1.60	9.6	1.50	9.8	1.40		
65	9.0	1.50	9.5	1.40	9.6	1.40	10.1	1.35	10.3	1.25		
62	9.9	1.25	10.4	1.20	10.4	1.20	10.8	1.15	11.0	1.10		
60			10.9	1.05	10.9	1.05	11.3	1.00				
57							12.0	0.85				
A(°)	45~82				60~82				75~82			

15.0mブーム+6.5mジブ												
ジブオフセット	7°		15°		30°		45°		60°		75°	
ブーム角度 (°)	作業半径 (m)	定格総荷重 (t)	作業半径 (m)	定格総荷重 (t)	作業半径 (m)	定格総荷重 (t)	作業半径 (m)	定格総荷重 (t)	作業半径 (m)	定格総荷重 (t)	作業半径 (m)	定格総荷重 (t)
82	4.0	1.80	4.8	1.80	6.3	1.80	7.5	1.80	8.3	1.80	8.6	1.75
80	4.7	1.80	5.6	1.80	7.0	1.80	8.1	1.80	8.8	1.80	9.1	1.75
78	5.5	1.80	6.3	1.80	7.7	1.80	8.8	1.80	9.4	1.70	9.6	1.70
74	6.9	1.80	7.7	1.80	9.0	1.75	10.0	1.50	10.5	1.40		
72	7.6	1.80	8.3	1.80	9.6	1.55	10.6	1.35	11.1	1.25		
70	8.2	1.70	9.0	1.65	10.3	1.35	11.2	1.20	11.6	1.15		
67	9.2	1.45	10.0	1.35	11.2	1.15	12.0	1.05	12.4	1.00		
65	9.9	1.30	10.6	1.20	11.8	1.05	12.5	0.95	12.8	0.90		
62	10.8	1.10	11.5	1.05	12.6	0.85	13.3	0.80				
60	11.5	1.00	12.1	0.90	13.2	0.75	13.8	0.70				
57			13.0	0.75	14.0	0.60						
A(°)	50~82		45~82				60~82				75~82	

15.0mブーム+8.9mジブ												
ジブオフセット	7°		15°		30°		45°		60°		75°	
ブーム角度 (°)	作業半径 (m)	定格総荷重 (t)	作業半径 (m)	定格総荷重 (t)	作業半径 (m)	定格総荷重 (t)	作業半径 (m)	定格総荷重 (t)	作業半径 (m)	定格総荷重 (t)	作業半径 (m)	定格総荷重 (t)
82	4.7	1.20	5.9	1.20	7.9	1.20	9.5	1.20	10.5	1.20	11.0	1.15
80	5.5	1.20	6.7	1.20	8.7	1.20	10.2	1.20	11.2	1.20	11.5	1.15
78	6.3	1.20	7.4	1.20	9.4	1.20	10.8	1.20	11.8	1.20	12.0	1.15
74	7.8	1.20	9.0	1.20	10.8	1.20	12.2	1.20	12.9	1.05		
72	8.6	1.10	9.7	1.20	11.5	1.20	12.8	1.05	13.5	0.95		
70	9.4	1.00	10.5	1.10	12.2	1.10	13.4	0.95	14.0	0.90		
67	10.5	0.80	11.5	1.00	13.2	0.90	14.3	0.80	14.8	0.80		
65	11.2	0.70	12.2	0.90	13.8	0.80	14.9	0.70	15.3	0.70		
62	12.3	0.60	13.2	0.80	14.8	0.70	15.7	0.55	16.0	0.55		
60	12.9	0.55	13.9	0.70	15.3	0.60	16.2	0.45				
57					16.2	0.40	16.9	0.35				
A(°)	45~82				60~82				75~82			

15.0mブーム+13.6mジブ												
ジブオフセット	7°		15°		30°		45°		60°		75°	
ブーム角度 (°)	作業半径 (m)	定格総荷重 (t)	作業半径 (m)	定格総荷重 (t)	作業半径 (m)	定格総荷重 (t)	作業半径 (m)	定格総荷重 (t)	作業半径 (m)	定格総荷重 (t)	作業半径 (m)	定格総荷重 (t)
82	6.1	0.70	7.9	0.70	11.0	0.70	13.4	0.65	14.9	0.58	15.6	0.55
80	7.0	0.70	8.8	0.70	11.9	0.70	14.2	0.65	15.6	0.58	16.1	0.55
78	8.0	0.70	9.7	0.70	12.7	0.70	14.9	0.65	16.3	0.58	16.7	0.55
74	9.9	0.70	11.6	0.70	14.4	0.70	16.4	0.61	17.5	0.57		
72	10.8	0.60	12.4	0.65	15.2	0.70	17.1	0.59	18.1	0.56		
70	11.7	0.50	13.3	0.60	16.0	0.70	17.8	0.56	18.7	0.55		
67	13.0	0.45	14.6	0.52	17.1	0.70	18.8	0.51	19.5	0.45		
65	13.9	0.35	15.4	0.48	17.8	0.55	19.4	0.45	20.0	0.35		
62	15.1	0.30	16.6	0.42	18.9	0.40						
60	15.9	0.25			19.6	0.30						
A(°)	50~82				55~82				60~82		75~82	

15.0mブーム+15.9mジブ												
ジブオフセット	7°		15°		30°		45°		60°		75°	
ブーム角度 (°)	作業半径 (m)	定格総荷重 (t)	作業半径 (m)	定格総荷重 (t)	作業半径 (m)	定格総荷重 (t)	作業半径 (m)	定格総荷重 (t)	作業半径 (m)	定格総荷重 (t)	作業半径 (m)	定格総荷重 (t)
82	6.8	0.65	8.8	0.65	12.3	0.40	15.1	0.30	17.0	0.27	17.9	0.27
80	7.8	0.65	9.9	0.65	13.3	0.40	16.0	0.30	17.7	0.27	18.4	0.27
78	8.9	0.65	10.9	0.60	14.2	0.40	16.8	0.30	18.4	0.27	19.0	0.27
74	10.9	0.55	12.8	0.52	16.0	0.37	18.3	0.30	19.7	0.27		
72	11.9	0.45	13.8	0.49	16.8	0.36	19.1	0.29	20.3	0.27		
70	12.8	0.40	14.7	0.46	17.7	0.35	19.8	0.28	20.9	0.27		
67	14.3	0.33	16.1	0.42	18.9	0.33	20.8	0.27	21.7	0.27		
65	15.2	0.28	17.0	0.38	19.7	0.32	21.5	0.26	22.3	0.27		
62	16.6	0.22	18.2	0.34	20.8	0.30	22.4	0.25	23.0	0.27		
60	17.4	0.18	19.1	0.31	21.5	0.28	23.0	0.25				
A(°)	50~82				55~82				60~82		75~82	

A：ブーム角度の範囲（無負荷時）

11.8mブーム+4.1mジブ												
ジブオフセット	※7°		※15°		30°		45°		60°		75°	
ブーム角度 (°)	作業半径 (m)	定格総荷重 (t)	作業半径 (m)	定格総荷重 (t)	作業半径 (m)	定格総荷重 (t)	作業半径 (m)	定格総荷重 (t)	作業半径 (m)	定格総荷重 (t)	作業半径 (m)	定格総荷重 (t)
82	2.8	1.80	3.4	1.80	4.0	1.80	4.8	1.80	5.3	1.80	5.5	1.80
80	3.4	1.80	3.9	1.80	4.5	1.80	5.3	1.80	5.7	1.80	5.9	1.80
78	3.9	1.80	4.6	1.80	5.1	1.80	5.7	1.80	6.2	1.80		
74	5.1	1.80	5.7	1.80	6.0	1.80	6.7	1.80	7.0	1.80		
72	5.6	1.80	6.1	1.80	6.5	1.80	7.1	1.80	7.4	1.80		
70	6.1	1.80	6.7	1.80	7.0	1.80	7.6	1.80	7.9	1.80		
67	6.9	1.65	7.5	1.80	7.7	1.80	8.2	1.80	8.4	1.75		
65	7.5	1.60	8.0	1.70	8.1	1.80	8.6	1.70	8.8	1.70		
62	8.2	1.55	8.7	1.60	8.8	1.65	9.2	1.50				
60	8.7	1.45	9.2	1.50	9.2	1.55	9.6	1.40				
57	9.4	1.30	9.9	1.30	9.8	1.35	10.1	1.25				
55	9.8	1.15	10.3	1.20	10.2	1.25	10.5	1.15				
52	10.5	1.05	11.0	1.05	10.7	1.10	11.0	1.05				
50	10.9	0.95			11.1	1.00						
45					11.9	0.83						
A(°)	30~82		25~82		30~82		45~82		60~82		75~82	

11.8mブーム+6.5mジブ												
ジブオフセット	7°		15°		30°		45°		60°		75°	
ブーム角度 (°)	作業半径 (m)	定格総荷重 (t)	作業半径 (m)	定格総荷重 (t)	作業半径 (m)	定格総荷重 (t)	作業半径 (m)	定格総荷重 (t)	作業半径 (m)	定格総荷重 (t)	作業半径 (m)	定格総荷重 (t)
82	3.3	1.80	4.2	1.80	5.6	1.80	6.8	1.80	7.6	1.80	8.0	1.80
80	4.0	1.80	4.8	1.80	6.2	1.80	7.3	1.80	8.1	1.80	8.4	1.80
78	4.6	1.80	5.4	1.80	6.8	1.80	7.9	1.80	8.6	1.80	8.8	1.80
74	5.8	1.80	6.6	1.80	7.9	1.80	8.9	1.80	9.5	1.70		
72	6.4	1.80	7.1	1.80	8.4	1.80	9.4	1.70	9.9	1.55		
70	6.9	1.75	7.7	1.80	9.0	1.75	9.9	1.55	10.3	1.45		
67	7.8	1.45	8.5	1.80	9.7	1.55	10.5	1.35	10.9	1.30		
65	8.3	1.35	9.1	1.55	10.2	1.40	11.0	1.25	11.3	1.20		
62	9.2	1.20	9.9	1.35	10.9	1.20	11.6	1.10	11.9	1.05		
60	9.7	1.05	10.4	1.25	11.4	1.10	12.0	1.05	12.2	1.00		
57	10.4	0.93	11.1	1.10	12.1	1.00	12.6	0.95				
55	10.9	0.85	11.6	1.00	12.5	0.90	13.0	0.85				
52	11.6	0.78	12.2	0.88	13.1	0.80	13.5	0.75				
50	12.1	0.73	12.7	0.80	13.5	0.70	13.8	0.65				
45	13.2	0.63										
A(°)	30~82		25~82		30~82		45~82		60~82		75~82	

11.8mブーム+8.9mジブ												
ジブオフセット	7°		15°		30°		45°		60°		75°	
ブーム角度 (°)	作業半径 (m)	定格総荷重 (t)	作業半径 (m)	定格総荷重 (t)	作業半径 (m)	定格総荷重 (t)	作業半径 (m)	定格総荷重 (t)	作業半径 (m)	定格総荷重 (t)	作業半径 (m)	定格総荷重 (t)
82	4.0	1.20	5.2	1.20	7.2	1.20	8.8	1.20	9.9	1.20	10.3	1.20
80	4.7	1.20	5.9	1.20	7.8	1.20	9.4	1.20	10.4	1.20	10.8	1.20
78	5.4	1.20	6.5	1.20	8.5	1.20	9.9	1.20	10.9	1.20	11.2	1.20
74	6.8	1.20	7.9	1.20	9.7	1.20	11.0	1.20	11.8	1.20		
72	7.4	1.15	8.5	1.20	10.3	1.20	11.6	1.20	12.3	1.20		
70	8.1	1.00	9.1	1.15	10.9	1.20	12.1	1.20	12.7	1.10		
67	9.0	0.85	10.1	1.00	11.7	1.15	12.8	1.05	13.4	1.00		
65	9.7	0.75	10.7	0.93	12.3	1.10	13.3	0.98	13.8	0.95		
62	10.6	0.65	11.5	0.85	13.0	1.00	14.0	0.85				
60	11.2	0.60	12.1	0.80	13.5	0.90	14.4	0.80				
57	12.0	0.50	12.9	0.70	14.3	0.75	15.0	0.70				
55	12.6	0.45	13.4	0.68	14.7	0.70	15.4	0.63				
52	13.4	0.40	14.2	0.63	15.4	0.57	15.9	0.51				
50	13.9	0.37	14.7	0.59	15.8	0.50	16.2	0.45				
A(°)	35~82		25~82		30~82		45~82		60~82		75~82	

11.8mブーム+13.6mジブ												
ジブオフセット	7°		15°		30°		45°		60°		75°	
ブーム角度 (°)	作業半径 (m)	定格総荷重 (t)	作業半径 (m)	定格総荷重 (t)	作業半径 (m)	定格総荷重 (t)	作業半径 (m)	定格総荷重 (t)	作業半径 (m)	定格総荷重 (t)	作業半径 (m)	定格総荷重 (t)
82	5.4	0.70	7.2	0.70	10.2	0.70	12.7	0.70	14.3	0.58	15.0	0.55
80	6.2	0.70	8.0	0.70	11.0	0.70	13.4	0.69	14.8	0.58	15.5	0.55
78	7.1	0.70	8.8	0.70	11.8	0.70	14.0	0.67	15.4	0.58		
74	8.7	0.70	10.4	0.70	13.2	0.70	15.3	0.65	16.4	0.57		
72	9.5	0.65	11.2	0.70	13.9	0.70	15.9	0.63	16.9	0.57		
70	10.3	0.55	12.0	0.60	14.6	0.70	16.5	0.61	17.4	0.56		
67	11.5	0.45	13.1	0.55	15.6	0.70	17.3	0.59	18.0	0.55		
65	12.3	0.39	13.8	0.50	16.2	0.68	17.8	0.58	18.5	0.55		
62	13.4	0.33	14.9	0.45	17.1	0.62	18.6	0.54	19.0	0.54		
60	14.1	0.29	15.5	0.42	17.7	0.58	19.0	0.50				
57	15.2	0.24					19.7	0.35				
A(°)	40~82		35~82		45~82		60~82		75~82			

11.8mブーム+15.9mジブ												
ジブオフセット	7°		15°		30°		45°		60°		75°	
ブーム角度 (°)	作業半径 (m)	定格総荷重 (t)	作業半径 (m)	定格総荷重 (t)	作業半径 (m)	定格総荷重 (t)	作業半径 (m)	定格総荷重 (t)	作業半径 (m)	定格総荷重 (t)	作業半径 (m)	定格総荷重 (t)
82	6.1	0.65	8.1	0.65	11.6	0.40	14.5	0.30	16.4	0.27	17.3	0.27
80	7.0	0.65	9.0	0.65	12.5	0.40	15.2	0.30	17.0	0.27	17.7	0.27
78	7.9	0.65	9.9	0.60	13.3	0.40	15.9	0.30	17.6	0.27	18.2	0.27
74	9.8	0.60	11.7	0.53	14.9	0.40	17.3	0.30	18.7	0.27		
72	10.6	0.48	12.5	0.51	15.6	0.37	17.9	0.29	19.2	0.27		
70	11.5	0.42	13.4	0.48	16.4	0.35	18.5	0.28	19.7	0.27		
67	12.8	0.32	14.6	0.42	17.4	0.33	19.4	0.28	20.3	0.27		
65	13.6	0.27	15.4	0.38	18.1	0.32	20.0	0.27	20.8	0.27		
62	14.8	0.20	16.5	0.34	19.1	0.30	20.8	0.26				
60			17.2	0.32	19.7	0.29	21.3	0.26				
57							21.9	0.25				
A(°)			45~82		50~82		60~82		75~82			

ジブオフセット	※7°		※15°		30°		45°		60°		75°	
ブーム角度 (°)	作業半径 (m)	定格総荷重 (t)	作業半径 (m)	定格総荷重 (t)	作業半径 (m)	定格総荷重 (t)	作業半径 (m)	定格総荷重 (t)	作業半径 (m)	定格総荷重 (t)	作業半径 (m)	定格総荷重 (t)
82	2.3	1.80	2.9	1.80	3.5	1.80	4.2	1.80	4.8	1.80	5.0	1.80
80	2.8	1.80	3.4	1.80	3.9	1.80	4.6	1.80	5.1	1.80	5.3	1.80
78	3.2	1.80	3.9	1.80	4.3	1.80	5.0	1.80	5.4	1.80	5.6	1.80
74	4.1	1.80	4.7	1.80	5.1	1.80	5.7	1.80	6.1	1.80		
72	4.6	1.80	5.2	1.80	5.5	1.80	6.1	1.80	6.4	1.80		
70	5.0	1.80	5.6	1.80	5.8	1.80	6.4	1.80	6.7	1.80		
67	5.6	1.70	6.2	1.75	6.4	1.80	6.9	1.80	7.1	1.80		
65	6.1	1.65	6.6	1.70	6.7	1.80	7.2	1.80				
62	6.7	1.60	7.2	1.65	7.2	1.80	7.7	1.80				
60	7.1	1.55	7.6	1.65	7.5	1.80	7.9	1.80				
57	7.7	1.50	8.1	1.60	8.0	1.80	8.4	1.70				
55	8.0	1.45	8.5	1.55	8.3	1.75	8.6	1.65				
52	8.5	1.40	9.0	1.45	8.7	1.60	9.0	1.55				
50	8.9	1.35			9.0	1.55						
A(°)	7~82		15~82		30~82		45~82		60~82		75~82	

ジブオフセット	7°		15°		30°		45°		60°		75°	
ブーム角度 (°)	作業半径 (m)	定格総荷重 (t)	作業半径 (m)	定格総荷重 (t)	作業半径 (m)	定格総荷重 (t)	作業半径 (m)	定格総荷重 (t)	作業半径 (m)	定格総荷重 (t)	作業半径 (m)	定格総荷重 (t)
82	2.8	1.80	3.6	1.80	5.1	1.80	6.2	1.80	7.1	1.80	7.4	1.80
80	3.3	1.80	4.1	1.80	5.5	1.80	6.7	1.80	7.4	1.80	7.8	1.80
78	3.8	1.80	4.6	1.80	6.0	1.80	7.1	1.80	7.8	1.80	8.1	1.80
74	4.8	1.80	5.6	1.80	6.9	1.80	7.9	1.80	8.5	1.80		
72	5.3	1.80	6.0	1.80	7.3	1.80	8.3	1.80	8.8	1.80		
70	5.7	1.80	6.5	1.80	7.8	1.80	8.7	1.80	9.1	1.80		
67	6.4	1.50	7.2	1.70	8.4	1.80	9.2	1.75	9.6	1.65		
65	6.9	1.35	7.6	1.60	8.8	1.80	9.5	1.60	9.9	1.55		
62	7.6	1.20	8.3	1.45	9.3	1.65	10.0	1.50				
60	8.0	1.10	8.7	1.35	9.7	1.55	10.3	1.40				
57	8.6	0.95	9.3	1.25	10.2	1.45	10.8	1.30				
55	9.0	0.90	9.6	1.15	10.6	1.35	11.1	1.25				
52	9.6	0.80	10.2	1.05	11.0	1.25	11.4	1.15				
50	10.0	0.75	10.5	1.00	11.3	1.15	11.7	1.10				
45					12.0	1.00						
A(°)	7~82		15~82		30~82		45~82		60~82		75~82	

ジブオフセット	7°		15°		30°		45°		60°		75°	
ブーム角度 (°)	作業半径 (m)	定格総荷重 (t)	作業半径 (m)	定格総荷重 (t)	作業半径 (m)	定格総荷重 (t)	作業半径 (m)	定格総荷重 (t)	作業半径 (m)	定格総荷重 (t)	作業半径 (m)	定格総荷重 (t)
82	3.4	1.20	4.6	1.20	6.6	1.20	8.2	1.20	9.3	1.20	9.8	1.20
80	4.0	1.20	5.2	1.20	7.1	1.20	8.7	1.20	9.7	1.20	10.2	1.20
78	4.6	1.20	5.7	1.20	7.7	1.20	9.2	1.20	10.1	1.20		
74	5.8	1.20	6.8	1.20	8.7	1.20	10.0	1.20	10.8	1.20		
72	6.3	1.20	7.4	1.15	9.2	1.20	10.5	1.20	11.2	1.20		
70	6.9	1.00	7.9	1.15	9.6	1.20	10.9	1.20	11.5	1.20		
67	7.7	0.85	8.7	1.05	10.3	1.20	11.5	1.20	12.0	1.20		
65	8.2	0.75	9.2	0.95	10.8	1.20	11.8	1.20				
62	9.0	0.65	9.9	0.85	11.4	1.15	12.4	1.15				
60	9.5	0.60	10.4	0.80	11.8	1.10	12.7	1.10				
57	10.2	0.52	11.1	0.75	12.4	1.05	13.2	1.00				
55	10.7	0.48	11.5	0.70	12.8	1.00	13.5	0.95				
52	11.3	0.40	12.1	0.65	13.3	0.95	13.9	0.88				
50	11.8	0.37	12.5	0.60	13.6	0.90	14.1	0.84				
A(°)	20~82		15~82		30~82		45~82		60~82		75~82	

ジブオフセット	7°		15°		30°		45°		60°		75°	
ブーム角度 (°)	作業半径 (m)	定格総荷重 (t)	作業半径 (m)	定格総荷重 (t)	作業半径 (m)	定格総荷重 (t)	作業半径 (m)	定格総荷重 (t)	作業半径 (m)	定格総荷重 (t)	作業半径 (m)	定格総荷重 (t)
82	4.8	0.70	6.5	0.70	9.6	0.70	12.1	0.68	13.7	0.60	14.5	0.55
80	5.5	0.70	7.3	0.70	10.3	0.70	12.6	0.68	14.2	0.59	14.8	0.55
78	6.3	0.70	8.0	0.70	10.9	0.70	13.2	0.68	14.6	0.58	15.1	0.55
74	7.7	0.70	9.4	0.70	12.2	0.70	14.3	0.64	15.5	0.57		
72	8.4	0.63	10.1	0.70	12.8	0.70	14.8	0.63	15.8	0.56		
70	9.1	0.53	10.7	0.62	13.4	0.70	15.2	0.61	16.2	0.56		
67	10.2	0.43	11.7	0.53	14.2	0.69	15.9	0.60	16.7	0.55		
65	10.8	0.35	12.3	0.48	14.7	0.68	16.3	0.59	17.0	0.55		
62	11.8	0.30	13.2	0.43	15.5	0.64	17.0	0.58				
60	12.4	0.27	13.8	0.40	16.0	0.62	17.3	0.57				
57					16.7	0.59	17.8	0.55				
A(°)	35~82		30~82		45~82		60~82		75~82			

ジブオフセット	7°		15°		30°		45°		60°		75°	
ブーム角度 (°)	作業半径 (m)	定格総荷重 (t)	作業半径 (m)	定格総荷重 (t)	作業半径 (m)	定格総荷重 (t)	作業半径 (m)	定格総荷重 (t)	作業半径 (m)	定格総荷重 (t)	作業半径 (m)	定格総荷重 (t)
82	5.5	0.65	7.5	0.65	11.1	0.40	13.9	0.30	15.9	0.27	16.8	0.27
80	6.3	0.65	8.3	0.65	11.8	0.40	14.5	0.30	16.4	0.27	17.2	0.27
78	7.1	0.65	9.1	0.65	12.5	0.40	15.1	0.30	16.8	0.27		
74	8.7	0.60	10.6	0.56	13.9	0.38	16.3	0.30	17.7	0.27		
72	9.5	0.50	11.4	0.53	14.5	0.37	16.8	0.30	18.1	0.27		
70	10.3	0.40	12.1	0.50	15.2	0.35	17.3	0.30	18.5	0.27		
67	11.4	0.33	13.2	0.44	16.1	0.34	18.1	0.29	19.0	0.27		
65	12.2	0.29	13.9	0.40	16.7	0.33	18.5	0.28				
62	13.2	0.24	14.9	0.35	17.5	0.31	19.2	0.28				
60	13.9	0.20	15.5	0.32	18.0	0.30	19.6	0.27				
57					18.8	0.28	20.1	0.27				
A(°)	45~82		40~82		35~82		45~82		60~82		75~82	

A: ブーム角度の範囲 (無負荷時)

5.5mブーム+4.1mジブ												
ジブオフセット	※7°		※15°		30°		45°		60°		75°	
ブーム角度 (°)	作業半径 (m)	定格総荷重 (t)	作業半径 (m)	定格総荷重 (t)	作業半径 (m)	定格総荷重 (t)	作業半径 (m)	定格総荷重 (t)	作業半径 (m)	定格総荷重 (t)	作業半径 (m)	定格総荷重 (t)
82	1.8	1.80	2.5	1.80	3.0	1.80	3.8	1.80	4.3	1.80	4.6	1.80
80	2.2	1.80	2.8	1.80	3.3	1.80	4.0	1.80	4.5	1.80	4.8	1.80
78	2.6	1.80	3.2	1.80	3.6	1.80	4.3	1.80	4.8	1.80	4.9	1.80
74	3.3	1.80	3.9	1.80	4.2	1.80	4.8	1.80	5.2	1.80		
72	3.6	1.80	4.2	1.80	4.5	1.80	5.1	1.80	5.4	1.80		
70	3.9	1.80	4.5	1.80	4.7	1.80	5.3	1.80	5.6	1.80		
67	4.4	1.70	4.9	1.75	5.1	1.80	5.6	1.80	5.9	1.80		
65	4.7	1.65	5.2	1.70	5.4	1.80	5.8	1.80	6.1	1.80		
62	5.2	1.60	5.7	1.65	5.7	1.80	6.1	1.80				
60	5.5	1.55	6.0	1.60	5.9	1.80	6.3	1.80				
57	5.9	1.50	6.4	1.55	6.3	1.80	6.6	1.80				
55	6.1	1.45	6.6	1.55	6.5	1.80	6.8	1.80				
52	6.5	1.40	7.0	1.50	6.8	1.80	7.0	1.80				
50	6.8	1.40			6.9	1.80						
A(°)	7~82		15~82		30~82		45~82		60~82		75~82	

5.5mブーム+6.5mジブ												
ジブオフセット	7°		15°		30°		45°		60°		75°	
ブーム角度 (°)	作業半径 (m)	定格総荷重 (t)	作業半径 (m)	定格総荷重 (t)	作業半径 (m)	定格総荷重 (t)	作業半径 (m)	定格総荷重 (t)	作業半径 (m)	定格総荷重 (t)	作業半径 (m)	定格総荷重 (t)
82	2.3	1.80	3.1	1.80	4.6	1.80	5.8	1.80	6.6	1.80	7.0	1.80
80	2.7	1.80	3.5	1.80	4.9	1.80	6.1	1.80	6.8	1.80	7.2	1.80
78	3.1	1.80	3.9	1.80	5.3	1.80	6.4	1.80	7.1	1.80	7.4	1.80
74	3.9	1.80	4.6	1.80	6.0	1.80	7.0	1.80	7.6	1.80		
72	4.2	1.80	5.0	1.80	6.3	1.80	7.3	1.80	7.8	1.80		
70	4.6	1.80	5.4	1.80	6.6	1.80	7.5	1.80	8.0	1.80		
67	5.2	1.55	5.9	1.65	7.1	1.80	7.9	1.80				
65	5.5	1.40	6.2	1.55	7.4	1.80	8.2	1.80				
62	6.0	1.20	6.7	1.40	7.8	1.80	8.5	1.80				
60	6.4	1.10	7.0	1.35	8.1	1.80	8.7	1.80				
57	6.9	1.00	7.5	1.25	8.5	1.70	9.0	1.80				
55	7.2	0.90	7.8	1.20	8.7	1.65						
52	7.9	0.80	8.2	1.10	9.0	1.60						
50			8.5	1.05	9.3	1.55						
45					9.7	1.50						
A(°)	7~82		15~82		30~82		45~82		60~82		75~82	

5.5mブーム+8.9mジブ												
ジブオフセット	7°		15°		30°		45°		60°		75°	
ブーム角度 (°)	作業半径 (m)	定格総荷重 (t)	作業半径 (m)	定格総荷重 (t)	作業半径 (m)	定格総荷重 (t)	作業半径 (m)	定格総荷重 (t)	作業半径 (m)	定格総荷重 (t)	作業半径 (m)	定格総荷重 (t)
82	3.0	1.20	4.1	1.20	6.1	1.20	7.7	1.20	8.8	1.20	9.3	1.20
80	3.4	1.20	4.6	1.20	6.5	1.20	8.1	1.20	9.1	1.20	9.6	1.20
78	3.9	1.20	5.0	1.20	6.9	1.20	8.4	1.20	9.4	1.20		
74	4.8	1.20	5.9	1.20	7.7	1.20	9.1	1.20	9.9	1.20		
72	5.3	1.20	6.4	1.20	8.1	1.20	9.4	1.20	10.2	1.20		
70	5.8	1.05	6.8	1.15	8.5	1.20	9.7	1.20	10.4	1.20		
67	6.4	0.90	7.4	1.05	9.0	1.20	10.2	1.20	10.7	1.20		
65	6.8	0.78	7.8	0.97	9.4	1.20	10.5	1.20	10.9	1.20		
62	7.5	0.68	8.4	0.85	9.9	1.15	10.8	1.20	11.2	1.20		
60	7.9	0.63	8.8	0.80	10.2	1.10	11.1	1.20				
57	8.4	0.53	9.3	0.72	10.6	1.05	11.4	1.20				
55	8.8	0.48	9.7	0.68	10.9	1.00	11.6	1.20				
52	9.4	0.42	10.1	0.63	11.3	0.97	11.9	1.20				
50	9.7	0.38	10.5	0.60	11.5	0.94	12.0	1.20				
A(°)	7~82		15~82		30~82		45~82		60~82		75~82	

5.5mブーム+13.6mジブ												
ジブオフセット	7°		15°		30°		45°		60°		75°	
ブーム角度 (°)	作業半径 (m)	定格総荷重 (t)	作業半径 (m)	定格総荷重 (t)	作業半径 (m)	定格総荷重 (t)	作業半径 (m)	定格総荷重 (t)	作業半径 (m)	定格総荷重 (t)	作業半径 (m)	定格総荷重 (t)
82	4.3	0.70	6.0	0.70	9.1	0.70	11.6	0.68	13.2	0.55	14.0	0.55
80	4.9	0.70	6.7	0.70	9.7	0.70	12.0	0.68	13.6	0.55	14.3	0.55
78	5.6	0.70	7.3	0.70	10.2	0.70	12.5	0.66	13.9	0.55	14.5	0.55
74	6.8	0.70	8.4	0.70	11.2	0.70	13.3	0.64	14.5	0.55		
72	7.4	0.65	9.0	0.70	11.7	0.70	13.7	0.63	14.8	0.55		
70	8.0	0.55	9.6	0.65	12.2	0.70	14.1	0.62	15.1	0.55		
67	8.9	0.45	10.4	0.55	12.9	0.70	14.6	0.61				
65	9.4	0.40	10.9	0.50	13.3	0.69	15.0	0.60				
62	10.3	0.33	11.7	0.43	14.0	0.65	15.4	0.58				
60	10.8	0.27	12.2	0.39	14.4	0.63	15.7	0.57				
57			12.9	0.35	14.9	0.60	16.1	0.56				
A(°)	35~82		15~82		30~82		45~82		60~82		75~82	

5.5mブーム+15.9mジブ												
ジブオフセット	7°		15°		30°		45°		60°		75°	
ブーム角度 (°)	作業半径 (m)	定格総荷重 (t)	作業半径 (m)	定格総荷重 (t)	作業半径 (m)	定格総荷重 (t)	作業半径 (m)	定格総荷重 (t)	作業半径 (m)	定格総荷重 (t)	作業半径 (m)	定格総荷重 (t)
82	5.0	0.65	7.0	0.65	10.6	0.40	13.4	0.30	15.4	0.27	16.3	0.27
80	5.7	0.65	7.7	0.65	11.2	0.40	13.9	0.30	15.8	0.27	16.5	0.27
78	6.4	0.65	8.4	0.65	11.8	0.40	14.4	0.30	16.1	0.27		
74	7.8	0.55	9.7	0.56	12.9	0.38	15.4	0.30	16.8	0.27		
72	8.5	0.50	10.4	0.53	13.5	0.37	15.8	0.29	17.1	0.27		
70	9.1	0.43	11.0	0.50	14.0	0.36	16.2	0.29	17.4	0.27		
67	10.1	0.35	11.9	0.45	14.8	0.34	16.8	0.28	17.7	0.27		
65	10.8	0.30	12.5	0.40	15.3	0.33	17.1	0.28	18.0	0.27		
62	11.7	0.25	13.4	0.33	16.0	0.32	17.6	0.27				
60			13.9	0.30	16.4	0.31	17.9	0.27				
57					17.0	0.30						
A(°)	45~82		35~82		30~82		45~82		60~82		75~82	

15.0mブーム+4.1mジブ												
ジブオフセット	※7°		※15°		30°		45°		60°		75°	
ブーム角度 (°)	作業半径 (m)	定格総荷重 (t)	作業半径 (m)	定格総荷重 (t)	作業半径 (m)	定格総荷重 (t)	作業半径 (m)	定格総荷重 (t)	作業半径 (m)	定格総荷重 (t)	作業半径 (m)	定格総荷重 (t)
82	3.3	1.80	4.0	1.80	4.6	1.80	5.4	1.80	5.9	1.80	6.1	1.80
80	4.0	1.80	4.7	1.80	5.3	1.80	6.0	1.80	6.4	1.80	6.6	1.80
78	4.8	1.80	5.3	1.80	5.9	1.80	6.6	1.80	7.0	1.80	7.1	1.80
74	6.1	1.80	6.7	1.80	7.1	1.80	7.7	1.80	8.1	1.80		
72	6.8	1.80	7.4	1.80	7.7	1.80	8.2	1.80	8.6	1.70		
70	7.5	1.75	8.0	1.75	8.2	1.80	8.8	1.70	9.1	1.60		
67	8.4	1.65	8.9	1.55	9.1	1.60	9.6	1.50	9.8	1.40		
65	9.0	1.50	9.5	1.40	9.6	1.40	10.1	1.35	10.3	1.25		
62	9.9	1.25	10.4	1.20	10.4	1.20	10.8	1.15	11.0	1.10		
60			10.9	1.05	10.9	1.05	11.3	1.00				
57							12.0	0.80				
A(°)	45~82						60~82			75~82		

15.0mブーム+6.5mジブ												
ジブオフセット	7°		15°		30°		45°		60°		75°	
ブーム角度 (°)	作業半径 (m)	定格総荷重 (t)	作業半径 (m)	定格総荷重 (t)	作業半径 (m)	定格総荷重 (t)	作業半径 (m)	定格総荷重 (t)	作業半径 (m)	定格総荷重 (t)	作業半径 (m)	定格総荷重 (t)
82	4.0	1.80	4.8	1.80	6.3	1.80	7.5	1.80	8.3	1.80	8.6	1.75
80	4.7	1.80	5.6	1.80	7.0	1.80	8.1	1.80	8.8	1.80	9.1	1.75
78	5.5	1.80	6.3	1.80	7.7	1.80	8.8	1.80	9.4	1.70	9.6	1.70
74	6.9	1.80	7.7	1.80	9.0	1.75	10.0	1.50	10.5	1.40		
72	7.6	1.80	8.3	1.80	9.6	1.55	10.6	1.35	11.1	1.25		
70	8.2	1.70	9.0	1.65	10.3	1.35	11.2	1.20	11.6	1.15		
67	9.2	1.45	10.0	1.35	11.2	1.15	12.0	1.05	12.4	1.00		
65	9.9	1.30	10.6	1.20	11.8	1.05	12.5	0.95	12.8	0.90		
62	10.8	1.10	11.5	1.00	12.6	0.85	13.3	0.75				
60	11.5	0.95	12.1	0.85	13.2	0.70	13.8	0.65				
57			13.0	0.65	14.0	0.50						
A(°)	50~82			45~82				60~82			75~82	

15.0mブーム+8.9mジブ												
ジブオフセット	7°		15°		30°		45°		60°		75°	
ブーム角度 (°)	作業半径 (m)	定格総荷重 (t)	作業半径 (m)	定格総荷重 (t)	作業半径 (m)	定格総荷重 (t)	作業半径 (m)	定格総荷重 (t)	作業半径 (m)	定格総荷重 (t)	作業半径 (m)	定格総荷重 (t)
82	4.7	1.20	5.9	1.20	7.9	1.20	9.5	1.20	10.5	1.20	11.0	1.15
80	5.5	1.20	6.7	1.20	8.7	1.20	10.2	1.20	11.2	1.20	11.5	1.15
78	6.3	1.20	7.4	1.20	9.4	1.20	10.8	1.20	11.8	1.20	12.0	1.15
74	7.8	1.20	9.0	1.20	10.8	1.20	12.2	1.20	12.9	1.05		
72	8.6	1.10	9.7	1.20	11.5	1.20	12.8	1.05	13.5	0.95		
70	9.4	1.00	10.5	1.10	12.2	1.10	13.4	0.95	14.0	0.90		
67	10.5	0.80	11.5	1.00	13.2	0.90	14.3	0.80	14.8	0.75		
65	11.2	0.70	12.2	0.90	13.8	0.80	14.9	0.70	15.3	0.65		
62	12.3	0.60	13.2	0.80	14.8	0.60	15.7	0.53	16.0	0.50		
60	12.9	0.55	13.9	0.70	15.3	0.50	16.2	0.43				
57					16.2	0.35	16.9	0.30				
A(°)	45~82						60~82			75~82		

15.0mブーム+13.6mジブ													
ジブオフセット	7°		15°		30°		45°		60°		75°		
ブーム角度 (°)	作業半径 (m)	定格総荷重 (t)	作業半径 (m)	定格総荷重 (t)	作業半径 (m)	定格総荷重 (t)	作業半径 (m)	定格総荷重 (t)	作業半径 (m)	定格総荷重 (t)	作業半径 (m)	定格総荷重 (t)	
82	6.1	0.70	7.9	0.70	11.0	0.70	13.4	0.65	14.9	0.58	15.6	0.55	
80	7.0	0.70	8.8	0.70	11.9	0.70	14.2	0.65	15.6	0.58	16.1	0.55	
78	8.0	0.70	9.7	0.70	12.7	0.70	14.9	0.65	16.3	0.58	16.7	0.55	
74	9.9	0.70	11.6	0.70	14.4	0.70	16.4	0.61	17.5	0.57			
72	10.8	0.60	12.4	0.70	15.2	0.70	17.1	0.59	18.1	0.56			
70	11.7	0.50	13.3	0.60	16.0	0.70	17.8	0.56	18.7	0.55			
67	13.0	0.45	14.6	0.52	17.1	0.65	18.8	0.48	19.5	0.43			
65	13.9	0.35	15.4	0.48	17.8	0.50	19.4	0.40	20.0	0.30			
62					18.9	0.35							
60					19.6	0.25							
A(°)	50~82			52~82			57~82			60~82		75~82	

15.0mブーム+15.9mジブ													
ジブオフセット	7°		15°		30°		45°		60°		75°		
ブーム角度 (°)	作業半径 (m)	定格総荷重 (t)	作業半径 (m)	定格総荷重 (t)	作業半径 (m)	定格総荷重 (t)	作業半径 (m)	定格総荷重 (t)	作業半径 (m)	定格総荷重 (t)	作業半径 (m)	定格総荷重 (t)	
82	6.8	0.65	8.8	0.65	12.3	0.40	15.1	0.30	17.0	0.27	17.9	0.27	
80	7.8	0.65	9.9	0.65	13.3	0.40	16.0	0.30	17.7	0.27	18.4	0.27	
78	8.9	0.65	10.9	0.60	14.2	0.40	16.8	0.30	18.4	0.27	19.0	0.27	
74	10.9	0.55	12.8	0.52	16.0	0.37	18.3	0.30	19.7	0.27			
72	11.9	0.45	13.8	0.49	16.8	0.36	19.1	0.29	20.3	0.27			
70	12.8	0.40	14.7	0.46	17.7	0.35	19.8	0.28	20.9	0.27			
67	14.3	0.33	16.1	0.42	18.9	0.33	20.8	0.27	21.7	0.27			
65	15.2	0.28	17.0	0.38	19.7	0.32	21.5	0.26	22.3	0.27			
62	16.6	0.22	18.2	0.34	20.8	0.30	22.4	0.25	23.0	0.24			
60			19.1	0.31	21.5	0.28	23.0	0.20					
A(°)	52~82				55~82				60~82			75~82	

A: ブーム角度の範囲 (無負荷時)

11.8mブーム+4.1mジブ												
ジブオフセット	※7°		※15°		30°		45°		60°		75°	
ブーム角度 (°)	作業半径 (m)	定格総荷重 (t)	作業半径 (m)	定格総荷重 (t)	作業半径 (m)	定格総荷重 (t)	作業半径 (m)	定格総荷重 (t)	作業半径 (m)	定格総荷重 (t)	作業半径 (m)	定格総荷重 (t)
82	2.8	1.80	3.4	1.80	4.0	1.80	4.8	1.80	5.3	1.80	5.5	1.80
80	3.4	1.80	3.9	1.80	4.5	1.80	5.3	1.80	5.7	1.80	5.9	1.80
78	3.9	1.80	4.6	1.80	5.1	1.80	5.7	1.80	6.2	1.80		
74	5.1	1.80	5.7	1.80	6.0	1.80	6.7	1.80	7.0	1.80		
72	5.6	1.80	6.1	1.80	6.5	1.80	7.1	1.80	7.4	1.80		
70	6.1	1.80	6.7	1.80	7.0	1.80	7.6	1.80	7.9	1.80		
67	6.9	1.65	7.5	1.80	7.7	1.80	8.2	1.80	8.4	1.75		
65	7.5	1.60	8.0	1.70	8.1	1.80	8.6	1.70	8.8	1.70		
62	8.2	1.55	8.7	1.60	8.8	1.65	9.2	1.50				
60	8.7	1.45	9.2	1.50	9.2	1.55	9.6	1.40				
57	9.4	1.30	9.9	1.30	9.8	1.35	10.1	1.25				
55	9.8	1.15	10.3	1.20	10.2	1.25	10.5	1.15				
52	10.5	1.05	11.0	1.05	10.7	1.10	11.0	1.05				
50	10.9	0.95			11.1	1.00						
45					11.9	0.80						
A(°)	30~82		25~82		30~82		45~82		60~82		75~82	

11.8mブーム+6.5mジブ												
ジブオフセット	7°		15°		30°		45°		60°		75°	
ブーム角度 (°)	作業半径 (m)	定格総荷重 (t)	作業半径 (m)	定格総荷重 (t)	作業半径 (m)	定格総荷重 (t)	作業半径 (m)	定格総荷重 (t)	作業半径 (m)	定格総荷重 (t)	作業半径 (m)	定格総荷重 (t)
82	3.3	1.80	4.2	1.80	5.6	1.80	6.8	1.80	7.6	1.80	8.0	1.80
80	4.0	1.80	4.8	1.80	6.2	1.80	7.3	1.80	8.1	1.80	8.4	1.80
78	4.6	1.80	5.4	1.80	6.8	1.80	7.9	1.80	8.6	1.80	8.8	1.80
74	5.8	1.80	6.6	1.80	7.9	1.80	8.9	1.80	9.5	1.70		
72	6.4	1.80	7.1	1.80	8.4	1.80	9.4	1.70	9.9	1.55		
70	6.9	1.75	7.7	1.80	9.0	1.75	9.9	1.55	10.3	1.45		
67	7.8	1.45	8.5	1.80	9.7	1.55	10.5	1.35	10.9	1.30		
65	8.3	1.35	9.1	1.55	10.2	1.40	11.0	1.25	11.3	1.20		
62	9.2	1.20	9.9	1.35	10.9	1.20	11.6	1.10	11.9	1.05		
60	9.7	1.05	10.4	1.25	11.4	1.10	12.0	1.05				
57	10.4	0.93	11.1	1.10	12.1	1.00	12.6	0.90				
55	10.9	0.85	11.6	1.00	12.5	0.90	13.0	0.80				
52	11.6	0.78	12.2	0.88	13.1	0.75	13.5	0.70				
50	12.1	0.73	12.7	0.78	13.5	0.65	13.8	0.60				
45	13.2	0.63										
A(°)	35~82				30~82		45~82		60~82		75~82	

11.8mブーム+8.9mジブ												
ジブオフセット	7°		15°		30°		45°		60°		75°	
ブーム角度 (°)	作業半径 (m)	定格総荷重 (t)	作業半径 (m)	定格総荷重 (t)	作業半径 (m)	定格総荷重 (t)	作業半径 (m)	定格総荷重 (t)	作業半径 (m)	定格総荷重 (t)	作業半径 (m)	定格総荷重 (t)
82	4.0	1.20	5.2	1.20	7.2	1.20	8.8	1.20	9.9	1.20	10.3	1.20
80	4.7	1.20	5.9	1.20	7.8	1.20	9.4	1.20	10.4	1.20	10.8	1.20
78	5.4	1.20	6.5	1.20	8.5	1.20	9.9	1.20	10.9	1.20	11.2	1.20
74	6.8	1.20	7.9	1.20	9.7	1.20	11.0	1.20	11.8	1.20		
72	7.4	1.15	8.5	1.20	10.3	1.20	11.6	1.20	12.3	1.20		
70	8.1	1.00	9.1	1.15	10.9	1.20	12.1	1.20	12.7	1.10		
67	9.0	0.85	10.1	1.00	11.7	1.15	12.8	1.05	13.4	1.00		
65	9.7	0.75	10.7	0.93	12.3	1.10	13.3	0.98	13.8	0.95		
62	10.6	0.65	11.5	0.85	13.0	1.00	14.0	0.85				
60	11.2	0.60	12.1	0.80	13.5	0.90	14.4	0.77				
57	12.0	0.50	12.9	0.70	14.3	0.75	15.0	0.65				
55	12.6	0.45	13.4	0.68	14.7	0.65	15.4	0.58				
52	13.4	0.40	14.2	0.63	15.4	0.55	15.9	0.47				
50	13.9	0.37	14.7	0.55	15.8	0.45	16.2	0.40				
A(°)	35~82				30~82		45~82		60~82		75~82	

11.8mブーム+13.6mジブ												
ジブオフセット	7°		15°		30°		45°		60°		75°	
ブーム角度 (°)	作業半径 (m)	定格総荷重 (t)	作業半径 (m)	定格総荷重 (t)	作業半径 (m)	定格総荷重 (t)	作業半径 (m)	定格総荷重 (t)	作業半径 (m)	定格総荷重 (t)	作業半径 (m)	定格総荷重 (t)
82	5.4	0.70	7.2	0.70	10.2	0.70	12.7	0.70	14.3	0.58	15.0	0.55
80	6.2	0.70	8.0	0.70	11.0	0.70	13.4	0.69	14.8	0.58	15.5	0.55
78	7.1	0.70	8.8	0.70	11.8	0.70	14.0	0.67	15.4	0.58		
74	8.7	0.70	10.4	0.70	13.2	0.70	15.3	0.65	16.4	0.57		
72	9.5	0.65	11.2	0.70	13.9	0.70	15.9	0.63	16.9	0.57		
70	10.3	0.55	12.0	0.60	14.6	0.70	16.5	0.61	17.4	0.56		
67	11.5	0.45	13.1	0.55	15.6	0.70	17.3	0.59	18.0	0.55		
65	12.3	0.39	13.8	0.50	16.2	0.68	17.8	0.58	18.5	0.53		
62	13.4	0.33	14.9	0.45	17.1	0.62	18.6	0.50	19.0	0.50		
60	14.1	0.29	15.5	0.42	17.7	0.58	19.0	0.45				
57	15.2	0.24					19.7	0.30				
A(°)	40~82				35~82		45~82		60~82		75~82	

11.8mブーム+15.9mジブ												
ジブオフセット	7°		15°		30°		45°		60°		75°	
ブーム角度 (°)	作業半径 (m)	定格総荷重 (t)	作業半径 (m)	定格総荷重 (t)	作業半径 (m)	定格総荷重 (t)	作業半径 (m)	定格総荷重 (t)	作業半径 (m)	定格総荷重 (t)	作業半径 (m)	定格総荷重 (t)
82	6.1	0.65	8.1	0.65	11.6	0.40	14.5	0.30	16.4	0.27	17.3	0.27
80	7.0	0.65	9.0	0.65	12.5	0.40	15.2	0.30	17.0	0.27	17.7	0.27
78	7.9	0.65	9.9	0.60	13.3	0.40	15.9	0.30	17.6	0.27	18.2	0.27
74	9.8	0.60	11.7	0.53	14.9	0.38	17.3	0.30	18.7	0.27		
72	10.6	0.48	12.5	0.51	15.6	0.37	17.9	0.29	19.2	0.27		
70	11.5	0.42	13.4	0.48	16.4	0.35	18.5	0.28	19.7	0.27		
67	12.8	0.32	14.6	0.42	17.4	0.33	19.4	0.28	20.3	0.27		
65	13.6	0.27	15.4	0.38	18.1	0.32	20.0	0.27	20.8	0.27		
62	14.8	0.20	16.5	0.34	19.1	0.30	20.8	0.26				
60			17.2	0.32	19.7	0.29	21.3	0.25				
57							21.9	0.25				
A(°)			45~82				50~82		60~82		75~82	

ジブオフセット	※7°		※15°		30°		45°		60°		75°	
ブーム角度 (°)	作業半径 (m)	定格総荷重 (t)	作業半径 (m)	定格総荷重 (t)	作業半径 (m)	定格総荷重 (t)	作業半径 (m)	定格総荷重 (t)	作業半径 (m)	定格総荷重 (t)	作業半径 (m)	定格総荷重 (t)
82	2.3	1.80	2.9	1.80	3.5	1.80	4.2	1.80	4.8	1.80	5.0	1.80
80	2.8	1.80	3.4	1.80	3.9	1.80	4.6	1.80	5.1	1.80	5.3	1.80
78	3.2	1.80	3.9	1.80	4.3	1.80	5.0	1.80	5.4	1.80	5.6	1.80
74	4.1	1.80	4.7	1.80	5.1	1.80	5.7	1.80	6.1	1.80		
72	4.6	1.80	5.2	1.80	5.5	1.80	6.1	1.80	6.4	1.80		
70	5.0	1.80	5.6	1.80	5.8	1.80	6.4	1.80	6.7	1.80		
67	5.6	1.70	6.2	1.75	6.4	1.80	6.9	1.80	7.1	1.80		
65	6.1	1.65	6.6	1.70	6.7	1.80	7.2	1.80				
62	6.7	1.60	7.2	1.65	7.2	1.80	7.7	1.80				
60	7.1	1.55	7.6	1.65	7.5	1.80	7.9	1.80				
57	7.7	1.50	8.1	1.60	8.0	1.80	8.4	1.70				
55	8.0	1.45	8.5	1.55	8.3	1.75	8.6	1.65				
52	8.5	1.40	9.0	1.45	8.7	1.60	9.0	1.55				
50	8.9	1.35			9.0	1.55						
A(°)	7~82		15~82		30~82		45~82		60~82		75~82	

ジブオフセット	7°		15°		30°		45°		60°		75°	
ブーム角度 (°)	作業半径 (m)	定格総荷重 (t)	作業半径 (m)	定格総荷重 (t)	作業半径 (m)	定格総荷重 (t)	作業半径 (m)	定格総荷重 (t)	作業半径 (m)	定格総荷重 (t)	作業半径 (m)	定格総荷重 (t)
82	2.8	1.80	3.6	1.80	5.1	1.80	6.2	1.80	7.1	1.80	7.4	1.80
80	3.3	1.80	4.1	1.80	5.5	1.80	6.7	1.80	7.4	1.80	7.8	1.80
78	3.8	1.80	4.6	1.80	6.0	1.80	7.1	1.80	7.8	1.80	8.1	1.80
74	4.8	1.80	5.6	1.80	6.9	1.80	7.9	1.80	8.5	1.80		
72	5.3	1.80	6.0	1.80	7.3	1.80	8.3	1.80	8.8	1.80		
70	5.7	1.80	6.5	1.80	7.8	1.80	8.7	1.80	9.1	1.80		
67	6.4	1.50	7.2	1.70	8.4	1.80	9.2	1.75	9.6	1.65		
65	6.9	1.35	7.6	1.60	8.8	1.80	9.5	1.65	9.9	1.55		
62	7.6	1.20	8.3	1.45	9.3	1.65	10.0	1.50				
60	8.0	1.10	8.7	1.35	9.7	1.55	10.3	1.40				
57	8.6	0.95	9.3	1.25	10.2	1.45	10.8	1.30				
55	9.0	0.90	9.6	1.15	10.6	1.35	11.1	1.25				
52	9.6	0.80	10.2	1.05	11.0	1.25	11.4	1.15				
50	10.0	0.75	10.5	1.00	11.3	1.15	11.7	1.10				
45					12.0	1.00						
A(°)	7~82		15~82		30~82		45~82		60~82		75~82	

ジブオフセット	7°		15°		30°		45°		60°		75°	
ブーム角度 (°)	作業半径 (m)	定格総荷重 (t)	作業半径 (m)	定格総荷重 (t)	作業半径 (m)	定格総荷重 (t)	作業半径 (m)	定格総荷重 (t)	作業半径 (m)	定格総荷重 (t)	作業半径 (m)	定格総荷重 (t)
82	3.4	1.20	4.6	1.20	6.6	1.20	8.2	1.20	9.3	1.20	9.8	1.20
80	4.0	1.20	5.2	1.20	7.1	1.20	8.7	1.20	9.7	1.20	10.2	1.20
78	4.6	1.20	5.7	1.20	7.7	1.20	9.2	1.20	10.1	1.20		
74	5.8	1.20	6.8	1.20	8.7	1.20	10.0	1.20	10.8	1.20		
72	6.3	1.20	7.4	1.20	9.2	1.20	10.5	1.20	11.2	1.20		
70	6.9	1.00	7.9	1.15	9.6	1.20	10.9	1.20	11.5	1.20		
67	7.7	0.85	8.7	1.05	10.3	1.20	11.5	1.20	12.0	1.20		
65	8.2	0.75	9.2	0.95	10.8	1.20	11.8	1.20				
62	9.0	0.65	9.9	0.85	11.4	1.15	12.4	1.15				
60	9.5	0.60	10.4	0.80	11.8	1.10	12.7	1.10				
57	10.2	0.52	11.1	0.75	12.4	1.05	13.2	1.00				
55	10.7	0.48	11.5	0.70	12.8	1.00	13.5	0.95				
52	11.3	0.40	12.1	0.65	13.3	0.95	13.9	0.88				
50	11.8	0.37	12.5	0.60	13.6	0.88	14.1	0.84				
A(°)	20~82		15~82		30~82		45~82		60~82		75~82	

ジブオフセット	7°		15°		30°		45°		60°		75°	
ブーム角度 (°)	作業半径 (m)	定格総荷重 (t)	作業半径 (m)	定格総荷重 (t)	作業半径 (m)	定格総荷重 (t)	作業半径 (m)	定格総荷重 (t)	作業半径 (m)	定格総荷重 (t)	作業半径 (m)	定格総荷重 (t)
82	4.8	0.70	6.5	0.70	9.6	0.70	12.1	0.68	13.7	0.60	14.5	0.55
80	5.5	0.70	7.3	0.70	10.3	0.70	12.6	0.68	14.2	0.59	14.8	0.55
78	6.3	0.70	8.0	0.70	10.9	0.70	13.2	0.68	14.6	0.58	15.1	0.55
74	7.7	0.70	9.4	0.70	12.2	0.70	14.3	0.64	15.5	0.57		
72	8.4	0.63	10.1	0.70	12.8	0.70	14.8	0.63	15.8	0.56		
70	9.1	0.53	10.7	0.62	13.4	0.70	15.2	0.61	16.2	0.56		
67	10.2	0.43	11.7	0.53	14.2	0.69	15.9	0.60	16.7	0.55		
65	10.8	0.35	12.3	0.48	14.7	0.68	16.3	0.59	17.0	0.55		
62	11.8	0.30	13.2	0.43	15.5	0.64	17.0	0.58				
60	12.4	0.27	13.8	0.40	16.0	0.62	17.3	0.57				
57					16.7	0.59	17.8	0.55				
A(°)	35~82		30~82		45~82		60~82		75~82			

ジブオフセット	7°		15°		30°		45°		60°		75°	
ブーム角度 (°)	作業半径 (m)	定格総荷重 (t)	作業半径 (m)	定格総荷重 (t)	作業半径 (m)	定格総荷重 (t)	作業半径 (m)	定格総荷重 (t)	作業半径 (m)	定格総荷重 (t)	作業半径 (m)	定格総荷重 (t)
82	5.5	0.65	7.5	0.65	11.1	0.40	13.9	0.30	15.9	0.27	16.8	0.27
80	6.3	0.65	8.3	0.65	11.8	0.40	14.5	0.30	16.4	0.27	17.2	0.27
78	7.1	0.65	9.1	0.65	12.5	0.40	15.1	0.30	16.8	0.27		
74	8.7	0.60	10.6	0.56	13.9	0.38	16.3	0.30	17.7	0.27		
72	9.5	0.50	11.4	0.53	14.5	0.37	16.8	0.30	18.1	0.27		
70	10.3	0.40	12.1	0.50	15.2	0.35	17.3	0.30	18.5	0.27		
67	11.4	0.33	13.2	0.44	16.1	0.34	18.1	0.29	19.0	0.27		
65	12.2	0.29	13.9	0.40	16.7	0.33	18.5	0.28				
62	13.2	0.24	14.9	0.35	17.5	0.31	19.2	0.28				
60	13.9	0.20	15.5	0.32	18.0	0.30	19.6	0.27				
A(°)	45~82		40~82		45~82		60~82		75~82			

A: ブーム角度の範囲 (無負荷時)

5.5mブーム+4.1mジブ												
ジブオフセット	※7°		※15°		30°		45°		60°		75°	
ブーム角度 (°)	作業半径 (m)	定格総荷重 (t)	作業半径 (m)	定格総荷重 (t)	作業半径 (m)	定格総荷重 (t)	作業半径 (m)	定格総荷重 (t)	作業半径 (m)	定格総荷重 (t)	作業半径 (m)	定格総荷重 (t)
82	1.8	1.80	2.5	1.80	3.0	1.80	3.8	1.80	4.3	1.80	4.6	1.80
80	2.2	1.80	2.8	1.80	3.3	1.80	4.0	1.80	4.5	1.80	4.8	1.80
78	2.6	1.80	3.2	1.80	3.6	1.80	4.3	1.80	4.8	1.80	4.9	1.80
74	3.3	1.80	3.9	1.80	4.2	1.80	4.8	1.80	5.2	1.80		
72	3.6	1.80	4.2	1.80	4.5	1.80	5.1	1.80	5.4	1.80		
70	3.9	1.80	4.5	1.80	4.7	1.80	5.3	1.80	5.6	1.80		
67	4.4	1.70	4.9	1.75	5.1	1.80	5.6	1.80	5.9	1.80		
65	4.7	1.65	5.2	1.70	5.4	1.80	5.8	1.80	6.1	1.80		
62	5.2	1.60	5.7	1.65	5.7	1.80	6.1	1.80				
60	5.5	1.55	6.0	1.60	5.9	1.80	6.3	1.80				
57	5.9	1.50	6.4	1.55	6.3	1.80	6.6	1.80				
55	6.1	1.45	6.6	1.55	6.5	1.80	6.8	1.80				
52	6.5	1.40	7.0	1.50	6.8	1.80	7.0	1.80				
50	6.8	1.40			6.9	1.80						
A(°)	7~82		15~82		30~82		45~82		60~82		75~82	

5.5mブーム+6.5mジブ												
ジブオフセット	7°		15°		30°		45°		60°		75°	
ブーム角度 (°)	作業半径 (m)	定格総荷重 (t)	作業半径 (m)	定格総荷重 (t)	作業半径 (m)	定格総荷重 (t)	作業半径 (m)	定格総荷重 (t)	作業半径 (m)	定格総荷重 (t)	作業半径 (m)	定格総荷重 (t)
82	2.3	1.80	3.1	1.80	4.6	1.80	5.8	1.80	6.6	1.80	7.0	1.80
80	2.7	1.80	3.5	1.80	4.9	1.80	6.1	1.80	6.8	1.80	7.2	1.80
78	3.1	1.80	3.9	1.80	5.3	1.80	6.4	1.80	7.1	1.80	7.4	1.80
74	3.9	1.80	4.6	1.80	6.0	1.80	7.0	1.80	7.6	1.80		
72	4.2	1.80	5.0	1.80	6.3	1.80	7.3	1.80	7.8	1.80		
70	4.6	1.80	5.4	1.80	6.6	1.80	7.5	1.80	8.0	1.80		
67	5.2	1.55	5.9	1.65	7.1	1.80	7.9	1.80				
65	5.5	1.40	6.2	1.55	7.4	1.80	8.2	1.80				
62	6.0	1.20	6.7	1.40	7.8	1.80	8.5	1.80				
60	6.4	1.10	7.0	1.35	8.1	1.80	8.7	1.80				
57	6.9	1.00	7.5	1.25	8.5	1.70	9.0	1.80				
55	7.2	0.90	7.8	1.20	8.7	1.65						
52	7.9	0.80	8.2	1.10	9.0	1.60						
50			8.5	1.05	9.3	1.55						
A(°)	7~82		15~82		30~82		45~82		60~82		75~82	

5.5mブーム+8.9mジブ												
ジブオフセット	7°		15°		30°		45°		60°		75°	
ブーム角度 (°)	作業半径 (m)	定格総荷重 (t)	作業半径 (m)	定格総荷重 (t)	作業半径 (m)	定格総荷重 (t)	作業半径 (m)	定格総荷重 (t)	作業半径 (m)	定格総荷重 (t)	作業半径 (m)	定格総荷重 (t)
82	3.0	1.20	4.1	1.20	6.1	1.20	7.7	1.20	8.8	1.20	9.3	1.20
80	3.4	1.20	4.6	1.20	6.5	1.20	8.1	1.20	9.1	1.20	9.6	1.20
78	3.9	1.20	5.0	1.20	6.9	1.20	8.4	1.20	9.4	1.20		
74	4.8	1.20	5.9	1.20	7.7	1.20	9.1	1.20	9.9	1.20		
72	5.3	1.20	6.4	1.20	8.1	1.20	9.4	1.20	10.2	1.20		
70	5.8	1.05	6.8	1.15	8.5	1.20	9.7	1.20	10.4	1.20		
67	6.4	0.90	7.4	1.05	9.0	1.20	10.2	1.20	10.7	1.20		
65	6.8	0.78	7.8	0.97	9.4	1.20	10.5	1.20	10.9	1.20		
62	7.5	0.68	8.4	0.85	9.9	1.15	10.8	1.20				
60	7.9	0.63	8.8	0.80	10.2	1.10	11.1	1.20				
57	8.4	0.53	9.3	0.72	10.6	1.05	11.4	1.20				
55	8.8	0.48	9.7	0.68	10.9	1.00	11.6	1.20				
52	9.4	0.42	10.1	0.63	11.3	0.97	11.9	1.20				
50	9.7	0.38	10.5	0.60	11.5	0.94	12.0	1.20				
A(°)	7~82		15~82		30~82		45~82		60~82		75~82	

5.5mブーム+13.6mジブ												
ジブオフセット	7°		15°		30°		45°		60°		75°	
ブーム角度 (°)	作業半径 (m)	定格総荷重 (t)	作業半径 (m)	定格総荷重 (t)	作業半径 (m)	定格総荷重 (t)	作業半径 (m)	定格総荷重 (t)	作業半径 (m)	定格総荷重 (t)	作業半径 (m)	定格総荷重 (t)
82	4.3	0.70	6.0	0.70	9.1	0.70	11.6	0.68	13.2	0.55	14.0	0.55
80	4.9	0.70	6.7	0.70	9.7	0.70	12.0	0.68	13.6	0.55	14.3	0.55
78	5.6	0.70	7.3	0.70	10.2	0.70	12.5	0.66	13.9	0.55	14.5	0.55
74	6.8	0.70	8.4	0.70	11.2	0.70	13.3	0.64	14.5	0.55		
72	7.4	0.65	9.0	0.70	11.7	0.70	13.7	0.63	14.8	0.55		
70	8.0	0.55	9.6	0.65	12.2	0.70	14.1	0.62	15.1	0.55		
67	8.9	0.45	10.4	0.55	12.9	0.70	14.6	0.61				
65	9.4	0.40	10.9	0.50	13.3	0.69	15.0	0.60				
62	10.3	0.33	11.7	0.43	14.0	0.65	15.4	0.58				
60	10.8	0.27	12.2	0.39	14.4	0.63	15.7	0.57				
57			12.9	0.35	14.9	0.60	16.1	0.56				
A(°)	35~82		15~82		30~82		45~82		60~82		75~82	

5.5mブーム+15.9mジブ												
ジブオフセット	7°		15°		30°		45°		60°		75°	
ブーム角度 (°)	作業半径 (m)	定格総荷重 (t)	作業半径 (m)	定格総荷重 (t)	作業半径 (m)	定格総荷重 (t)	作業半径 (m)	定格総荷重 (t)	作業半径 (m)	定格総荷重 (t)	作業半径 (m)	定格総荷重 (t)
82	5.0	0.65	7.0	0.65	10.6	0.40	13.4	0.30	15.4	0.27	16.3	0.27
80	5.7	0.65	7.7	0.65	11.2	0.40	13.9	0.30	15.8	0.27	16.5	0.27
78	6.4	0.65	8.4	0.65	11.8	0.40	14.4	0.30	16.1	0.27		
74	7.8	0.55	9.7	0.56	12.9	0.38	15.4	0.30	16.8	0.27		
72	8.5	0.50	10.4	0.53	13.5	0.37	15.8	0.29	17.1	0.27		
70	9.1	0.43	11.0	0.50	14.0	0.36	16.2	0.29	17.4	0.27		
67	10.1	0.35	11.9	0.45	14.8	0.34	16.8	0.28	17.7	0.27		
65	10.8	0.30	12.5	0.40	15.3	0.33	17.1	0.28	18.0	0.27		
62	11.7	0.25	13.4	0.33	16.0	0.32	17.6	0.27				
60			13.9	0.30	16.4	0.31	17.9	0.27				
A(°)	45~82		35~82		30~82		45~82		60~82		75~82	

A: ブーム角度の範囲 (無負荷時)

15.0mブーム+4.1mジブ												
ジブオフセット	※7°		※15°		30°		45°		60°		75°	
ブーム角度 (°)	作業半径 (m)	定格総荷重 (t)	作業半径 (m)	定格総荷重 (t)	作業半径 (m)	定格総荷重 (t)	作業半径 (m)	定格総荷重 (t)	作業半径 (m)	定格総荷重 (t)	作業半径 (m)	定格総荷重 (t)
82	3.3	1.80	4.0	1.80	4.6	1.80	5.4	1.80	5.9	1.80	6.1	1.80
80	4.0	1.80	4.7	1.80	5.3	1.80	6.0	1.80	6.4	1.80	6.6	1.80
78	4.8	1.80	5.3	1.80	5.9	1.80	6.6	1.80	7.0	1.80	7.1	1.80
74	6.1	1.80	6.7	1.80	7.1	1.80	7.7	1.75	8.1	1.70		
72	6.8	1.75	7.4	1.65	7.7	1.60	8.2	1.55	8.6	1.45		
70	7.5	1.65	8.0	1.50	8.2	1.45	8.8	1.30	9.1	1.20		
67	8.4	1.25	8.9	1.15	9.1	1.10	9.6	1.00	9.8	0.95		
65	9.0	1.00	9.5	0.95	9.6	0.90	10.1	0.80	10.3	0.75		
62	9.9	0.75	10.4	0.65	10.4	0.65	10.8	0.60	11.0	0.55		
60			10.9	0.50	10.9	0.50	11.3	0.45				
57							12.0	0.25				
A(°)					52~82				60~82		75~82	

15.0mブーム+6.5mジブ												
ジブオフセット	7°		15°		30°		45°		60°		75°	
ブーム角度 (°)	作業半径 (m)	定格総荷重 (t)	作業半径 (m)	定格総荷重 (t)	作業半径 (m)	定格総荷重 (t)	作業半径 (m)	定格総荷重 (t)	作業半径 (m)	定格総荷重 (t)	作業半径 (m)	定格総荷重 (t)
82	4.0	1.80	4.8	1.80	6.3	1.80	7.5	1.80	8.3	1.65	8.6	1.65
80	4.7	1.80	5.6	1.80	7.0	1.80	8.1	1.80	8.8	1.65	9.1	1.65
78	5.5	1.80	6.3	1.80	7.7	1.75	8.8	1.60	9.4	1.45	9.6	1.40
74	6.9	1.80	7.7	1.80	9.0	1.40	10.0	1.15	10.5	1.05		
72	7.6	1.65	8.3	1.50	9.6	1.20	10.6	1.00	11.1	0.88		
70	8.2	1.45	9.0	1.25	10.3	0.95	11.2	0.80	11.6	0.75		
67	9.2	1.05	10.0	0.90	11.2	0.70	12.0	0.60	12.4	0.55		
65	9.9	0.80	10.6	0.70	11.8	0.55	12.5	0.45	12.8	0.43		
62	10.8	0.60	11.5	0.45	12.6	0.35						
60	11.5	0.40	12.1	0.30	13.2	0.20						
A(°)		52~82			55~82				57~82		60~82	75~82

15.0mブーム+8.9mジブ												
ジブオフセット	7°		15°		30°		45°		60°		75°	
ブーム角度 (°)	作業半径 (m)	定格総荷重 (t)	作業半径 (m)	定格総荷重 (t)	作業半径 (m)	定格総荷重 (t)	作業半径 (m)	定格総荷重 (t)	作業半径 (m)	定格総荷重 (t)	作業半径 (m)	定格総荷重 (t)
82	4.7	1.20	5.9	1.20	7.9	1.20	9.5	1.20	10.5	1.20	11.0	0.95
80	5.5	1.20	6.7	1.20	8.7	1.20	10.2	1.20	11.2	1.20	11.5	0.95
78	6.3	1.20	7.4	1.20	9.4	1.20	10.8	1.10	11.8	1.00	12.0	0.95
74	7.8	1.20	9.0	1.20	10.8	1.00	12.2	0.80	12.9	0.70		
72	8.6	1.10	9.7	1.05	11.5	0.80	12.8	0.70	13.5	0.60		
70	9.4	1.00	10.5	0.95	12.2	0.65	13.4	0.57	14.0	0.50		
67	10.5	0.80	11.5	0.70	13.2	0.45	14.3	0.38	14.8	0.35		
65	11.2	0.65	12.2	0.55	13.8	0.30	14.9	0.26				
62	12.3	0.45	13.2	0.30								
60	12.9	0.30	13.9	0.20								
A(°)			55~82			57~82			60~82		75~82	

15.0mブーム+13.6mジブ												
ジブオフセット	7°		15°		30°		45°		60°		75°	
ブーム角度 (°)	作業半径 (m)	定格総荷重 (t)	作業半径 (m)	定格総荷重 (t)	作業半径 (m)	定格総荷重 (t)	作業半径 (m)	定格総荷重 (t)	作業半径 (m)	定格総荷重 (t)	作業半径 (m)	定格総荷重 (t)
82	6.1	0.70	7.9	0.70	11.0	0.70	13.4	0.65	14.9	0.58	15.6	0.55
80	7.0	0.70	8.8	0.70	11.9	0.70	14.2	0.65	15.6	0.58	16.1	0.55
78	8.0	0.70	9.7	0.70	12.7	0.70	14.9	0.65	16.3	0.56	16.7	0.52
74	9.9	0.70	11.6	0.70	14.4	0.70	16.4	0.50	17.5	0.40		
72	10.8	0.60	12.4	0.70	15.2	0.53	17.1	0.38	18.1	0.29		
70	11.7	0.50	13.3	0.60	16.0	0.42	17.8	0.27				
67	13.0	0.45	14.6	0.45	17.1	0.28						
65	13.9	0.35										
A(°)			57~82		62~82		65~82		67~82		75~82	

15.0mブーム+15.9mジブ												
ジブオフセット	7°		15°		30°		45°		60°		75°	
ブーム角度 (°)	作業半径 (m)	定格総荷重 (t)	作業半径 (m)	定格総荷重 (t)	作業半径 (m)	定格総荷重 (t)	作業半径 (m)	定格総荷重 (t)	作業半径 (m)	定格総荷重 (t)	作業半径 (m)	定格総荷重 (t)
82	6.8	0.65	8.8	0.65	12.3	0.40	15.1	0.30	17.0	0.27	17.9	0.27
80	7.8	0.65	9.9	0.65	13.3	0.40	16.0	0.30	17.7	0.27	18.4	0.27
78	8.9	0.65	10.9	0.60	14.2	0.40	16.8	0.30	18.4	0.27	19.0	0.27
74	10.9	0.55	12.8	0.52	16.0	0.37	18.3	0.30	19.7	0.27		
72	11.9	0.45	13.8	0.49	16.8	0.36	19.1	0.29	20.3	0.25		
70	12.8	0.40	14.7	0.45	17.7	0.33	19.8	0.25	20.9	0.21		
67	14.3	0.33	16.1	0.34	18.9	0.23						
65	15.2	0.28	17.0	0.25								
A(°)			60~82		62~82		67~82		75~82			

A: ブーム角度の範囲 (無負荷時)

11.8mブーム+4.1mジブ														
ジブオフセット	※7°		※15°		30°		45°		60°		75°			
ブーム角度 (°)	作業半径 (m)	定格総荷重 (t)	作業半径 (m)	定格総荷重 (t)	作業半径 (m)	定格総荷重 (t)	作業半径 (m)	定格総荷重 (t)	作業半径 (m)	定格総荷重 (t)	作業半径 (m)	定格総荷重 (t)		
82	2.8	1.80	3.4	1.80	4.0	1.80	4.8	1.80	5.3	1.80	5.5	1.80		
80	3.4	1.80	3.9	1.80	4.5	1.80	5.3	1.80	5.7	1.80	5.9	1.80		
78	3.9	1.80	4.6	1.80	5.1	1.80	5.7	1.80	6.2	1.80				
74	5.1	1.80	5.7	1.80	6.0	1.80	6.7	1.80	7.0	1.80				
72	5.6	1.80	6.1	1.80	6.5	1.80	7.1	1.80	7.4	1.75				
70	6.1	1.75	6.7	1.75	7.0	1.80	7.6	1.70	7.9	1.70				
67	6.9	1.65	7.5	1.65	7.7	1.60	8.2	1.60	8.4	1.45				
65	7.5	1.60	8.0	1.50	8.1	1.50	8.6	1.40	8.8	1.30				
62	8.2	1.35	8.7	1.25	8.8	1.25	9.2	1.10						
60	8.7	1.15	9.2	1.05	9.2	1.10	9.6	0.95						
57	9.4	0.95	9.9	0.80	9.8	0.85	10.1	0.75						
55	9.8	0.80	10.3	0.70	10.2	0.73	10.5	0.65						
52	10.5	0.60	11.0	0.50	10.7	0.55	11.0	0.50						
50	10.9	0.45			11.1	0.43								
A(°)	35~82				40~82				45~82		60~82		75~82	

11.8mブーム+6.5mジブ												
ジブオフセット	7°		15°		30°		45°		60°		75°	
ブーム角度 (°)	作業半径 (m)	定格総荷重 (t)	作業半径 (m)	定格総荷重 (t)	作業半径 (m)	定格総荷重 (t)	作業半径 (m)	定格総荷重 (t)	作業半径 (m)	定格総荷重 (t)	作業半径 (m)	定格総荷重 (t)
82	3.3	1.80	4.2	1.80	5.6	1.80	6.8	1.80	7.6	1.80	8.0	1.60
80	4.0	1.80	4.8	1.80	6.2	1.80	7.3	1.80	8.1	1.80	8.4	1.60
78	4.6	1.80	5.4	1.80	6.8	1.80	7.9	1.80	8.6	1.75	8.8	1.60
74	5.8	1.80	6.6	1.80	7.9	1.80	8.9	1.60	9.5	1.40		
72	6.4	1.80	7.1	1.80	8.4	1.60	9.4	1.40	9.9	1.25		
70	6.9	1.70	7.7	1.75	9.0	1.40	9.9	1.20	10.3	1.10		
67	7.8	1.45	8.5	1.40	9.7	1.15	10.5	1.00	10.9	0.90		
65	8.3	1.30	9.1	1.20	10.2	1.00	11.0	0.85	11.3	0.80		
62	9.2	1.10	9.9	0.95	10.9	0.75	11.6	0.70	11.9	0.65		
60	9.7	0.95	10.4	0.80	11.4	0.65	12.0	0.60				
57	10.4	0.75	11.1	0.62	12.1	0.48	12.6	0.45				
55	10.9	0.60	11.6	0.50	12.5	0.40	13.0	0.35				
52	11.6	0.40	12.2	0.35	13.1	0.28						
50	12.1	0.30	12.7	0.25								
A(°)	40~82				45~82				60~82		75~82	

11.8mブーム+8.9mジブ												
ジブオフセット	7°		15°		30°		45°		60°		75°	
ブーム角度 (°)	作業半径 (m)	定格総荷重 (t)	作業半径 (m)	定格総荷重 (t)	作業半径 (m)	定格総荷重 (t)	作業半径 (m)	定格総荷重 (t)	作業半径 (m)	定格総荷重 (t)	作業半径 (m)	定格総荷重 (t)
82	4.0	1.20	5.2	1.20	7.2	1.20	8.8	1.20	9.9	1.20	10.3	1.20
80	4.7	1.20	5.9	1.20	7.8	1.20	9.4	1.20	10.4	1.20	10.8	1.20
78	5.4	1.20	6.5	1.20	8.5	1.20	9.9	1.20	10.9	1.20		
74	6.8	1.20	7.9	1.20	9.7	1.20	11.0	1.10	11.8	1.00		
72	7.4	1.15	8.5	1.20	10.3	1.20	11.6	0.95	12.3	0.85		
70	8.1	1.00	9.1	1.10	10.9	1.00	12.1	0.83	12.7	0.75		
67	9.0	0.85	10.1	0.98	11.7	0.80	12.8	0.68	13.4	0.62		
65	9.7	0.75	10.7	0.90	12.3	0.70	13.3	0.60	13.8	0.55		
62	10.6	0.65	11.5	0.70	13.0	0.55	14.0	0.45				
60	11.2	0.60	12.1	0.57	13.5	0.44	14.4	0.36				
57	12.0	0.50	12.9	0.40	14.3	0.30	15.0	0.25				
55	12.6	0.40	13.4	0.33	14.7	0.25						
52	13.4	0.30	14.2	0.22								
50	13.9	0.20										
A(°)	45~82				50~82				60~82		75~82	

11.8mブーム+13.6mジブ														
ジブオフセット	7°		15°		30°		45°		60°		75°			
ブーム角度 (°)	作業半径 (m)	定格総荷重 (t)	作業半径 (m)	定格総荷重 (t)	作業半径 (m)	定格総荷重 (t)	作業半径 (m)	定格総荷重 (t)	作業半径 (m)	定格総荷重 (t)	作業半径 (m)	定格総荷重 (t)		
82	5.4	0.70	7.2	0.70	10.2	0.70	12.7	0.70	14.3	0.58	15.0	0.55		
80	6.2	0.70	8.0	0.70	11.0	0.70	13.4	0.69	14.8	0.58	15.5	0.55		
78	7.1	0.70	8.8	0.70	11.8	0.70	14.0	0.67	15.4	0.58				
74	8.7	0.70	10.4	0.70	13.2	0.70	15.3	0.63	16.4	0.55				
72	9.5	0.65	11.2	0.70	13.9	0.70	15.9	0.56	16.9	0.50				
70	10.3	0.55	12.0	0.60	14.6	0.65	16.5	0.50	17.4	0.40				
67	11.5	0.45	13.1	0.55	15.6	0.50	17.3	0.40	18.0	0.20				
65	12.3	0.39	13.8	0.50	16.2	0.43	17.8	0.28						
62	13.4	0.33	14.9	0.45	17.1	0.33								
60	14.1	0.29	15.5	0.36										
57	15.2	0.24												
A(°)	45~82				50~82				52~82		60~82		75~82	

11.8mブーム+15.9mジブ														
ジブオフセット	7°		15°		30°		45°		60°		75°			
ブーム角度 (°)	作業半径 (m)	定格総荷重 (t)	作業半径 (m)	定格総荷重 (t)	作業半径 (m)	定格総荷重 (t)	作業半径 (m)	定格総荷重 (t)	作業半径 (m)	定格総荷重 (t)	作業半径 (m)	定格総荷重 (t)		
82	6.1	0.65	8.1	0.65	11.6	0.40	14.5	0.30	16.4	0.27	17.3	0.27		
80	7.0	0.65	9.0	0.65	12.5	0.40	15.2	0.30	17.0	0.27	17.7	0.27		
78	7.9	0.65	9.9	0.60	13.3	0.40	15.9	0.30	17.6	0.27	18.2	0.27		
74	9.8	0.60	11.7	0.53	14.9	0.38	17.3	0.30	18.7	0.27				
72	10.6	0.48	12.5	0.51	15.6	0.37	17.9	0.29	19.2	0.27				
70	11.5	0.42	13.4	0.48	16.4	0.35	18.5	0.28	19.7	0.27				
67	12.8	0.32	14.6	0.42	17.4	0.33	19.4	0.27	20.3	0.27				
65	13.6	0.27	15.4	0.38	18.1	0.31	20.0	0.25	20.8	0.22				
62	14.8	0.20	16.5	0.32	19.1	0.24								
60			17.2	0.27										
A(°)	52~82				55~82		57~82		60~82		62~82		75~82	

A: ブーム角度の範囲 (無負荷時)

ジブオフセット	※7°		※15°		30°		45°		60°		75°	
ブーム角度 (°)	作業半径 (m)	定格総荷重 (t)	作業半径 (m)	定格総荷重 (t)	作業半径 (m)	定格総荷重 (t)	作業半径 (m)	定格総荷重 (t)	作業半径 (m)	定格総荷重 (t)	作業半径 (m)	定格総荷重 (t)
82	2.3	1.80	2.9	1.80	3.5	1.80	4.2	1.80	4.8	1.80	5.0	1.80
80	2.8	1.80	3.4	1.80	3.9	1.80	4.6	1.80	5.1	1.80	5.3	1.80
78	3.2	1.80	3.9	1.80	4.3	1.80	5.0	1.80	5.4	1.80	5.6	1.80
74	4.1	1.80	4.7	1.80	5.1	1.80	5.7	1.80	6.1	1.80		
72	4.6	1.80	5.2	1.80	5.5	1.80	6.1	1.80	6.4	1.80		
70	5.0	1.80	5.6	1.80	5.8	1.80	6.4	1.80	6.7	1.80		
67	5.6	1.70	6.2	1.75	6.4	1.80	6.9	1.80	7.1	1.80		
65	6.1	1.65	6.6	1.70	6.7	1.80	7.2	1.75				
62	6.7	1.60	7.2	1.65	7.2	1.75	7.7	1.65				
60	7.1	1.55	7.6	1.60	7.5	1.65	7.9	1.60				
57	7.7	1.50	8.1	1.45	8.0	1.55	8.4	1.45				
55	8.0	1.35	8.5	1.35	8.3	1.40	8.6	1.30				
52	8.5	1.20	9.0	1.15	8.7	1.20	9.0	1.15				
50	8.9	1.05			9.0	1.10						
A(°)	7~82		15~82		30~82		45~82		60~82		75~82	

ジブオフセット	7°		15°		30°		45°		60°		75°	
ブーム角度 (°)	作業半径 (m)	定格総荷重 (t)	作業半径 (m)	定格総荷重 (t)	作業半径 (m)	定格総荷重 (t)	作業半径 (m)	定格総荷重 (t)	作業半径 (m)	定格総荷重 (t)	作業半径 (m)	定格総荷重 (t)
82	2.8	1.80	3.6	1.80	5.1	1.80	6.2	1.80	7.1	1.80	7.4	1.80
80	3.3	1.80	4.1	1.80	5.5	1.80	6.7	1.80	7.4	1.80	7.8	1.80
78	3.8	1.80	4.6	1.80	6.0	1.80	7.1	1.80	7.8	1.80	8.1	1.80
74	4.8	1.80	5.6	1.80	6.9	1.80	7.9	1.80	8.5	1.80		
72	5.3	1.80	6.0	1.80	7.3	1.80	8.3	1.75	8.8	1.65		
70	5.7	1.80	6.5	1.80	7.8	1.80	8.7	1.65	9.1	1.55		
67	6.4	1.50	7.2	1.70	8.4	1.65	9.2	1.50	9.6	1.35		
65	6.9	1.35	7.6	1.60	8.8	1.50	9.5	1.35	9.9	1.25		
62	7.6	1.20	8.3	1.45	9.3	1.30	10.0	1.15				
60	8.0	1.10	8.7	1.35	9.7	1.15	10.3	1.05				
57	8.6	0.95	9.3	1.20	10.2	1.00	10.8	0.90				
55	9.0	0.90	9.6	1.05	10.6	0.90	11.1	0.85				
52	9.6	0.80	10.2	0.90	11.0	0.75	11.4	0.73				
50	10.0	0.75	10.5	0.80	11.3	0.65	11.7	0.65				
A(°)	10~82		15~82		30~82		45~82		60~82		75~82	

ジブオフセット	7°		15°		30°		45°		60°		75°	
ブーム角度 (°)	作業半径 (m)	定格総荷重 (t)	作業半径 (m)	定格総荷重 (t)	作業半径 (m)	定格総荷重 (t)	作業半径 (m)	定格総荷重 (t)	作業半径 (m)	定格総荷重 (t)	作業半径 (m)	定格総荷重 (t)
82	3.4	1.20	4.6	1.20	6.6	1.20	8.2	1.20	9.3	1.20	9.8	1.20
80	4.0	1.20	5.2	1.20	7.1	1.20	8.7	1.20	9.7	1.20	10.2	1.20
78	4.6	1.20	5.7	1.20	7.7	1.20	9.2	1.20	10.1	1.20		
74	5.8	1.20	6.8	1.20	8.7	1.20	10.0	1.20	10.8	1.20		
72	6.3	1.20	7.4	1.20	9.2	1.20	10.5	1.15	11.2	1.20		
70	6.9	1.00	7.9	1.15	9.6	1.20	10.9	1.10	11.5	1.05		
67	7.7	0.85	8.7	1.05	10.3	1.15	11.5	1.00	12.0	0.90		
65	8.2	0.75	9.2	0.95	10.8	1.05	11.8	0.90				
62	9.0	0.65	9.9	0.85	11.4	0.90	12.4	0.75				
60	9.5	0.60	10.4	0.80	11.8	0.80	12.7	0.65				
57	10.2	0.52	11.1	0.75	12.4	0.65	13.2	0.55				
55	10.7	0.48	11.5	0.70	12.8	0.60	13.5	0.50				
52	11.3	0.40	12.1	0.63	13.3	0.50	13.9	0.45				
50	11.8	0.37	12.5	0.58	13.6	0.43	14.1	0.40				
A(°)	20~82		25~82		30~82		45~82		60~82		75~82	

ジブオフセット	7°		15°		30°		45°		60°		75°	
ブーム角度 (°)	作業半径 (m)	定格総荷重 (t)	作業半径 (m)	定格総荷重 (t)	作業半径 (m)	定格総荷重 (t)	作業半径 (m)	定格総荷重 (t)	作業半径 (m)	定格総荷重 (t)	作業半径 (m)	定格総荷重 (t)
82	4.8	0.70	6.5	0.70	9.6	0.70	12.1	0.68	13.7	0.60	14.5	0.55
80	5.5	0.70	7.3	0.70	10.3	0.70	12.6	0.68	14.2	0.59	14.8	0.55
78	6.3	0.70	8.0	0.70	10.9	0.70	13.2	0.68	14.6	0.58	15.1	0.55
74	7.7	0.70	9.4	0.70	12.2	0.70	14.3	0.64	15.5	0.57		
72	8.4	0.63	10.1	0.70	12.8	0.70	14.8	0.63	15.8	0.56		
70	9.1	0.53	10.7	0.62	13.4	0.70	15.2	0.61	16.2	0.54		
67	10.2	0.43	11.7	0.53	14.2	0.69	15.9	0.60	16.7	0.48		
65	10.8	0.35	12.3	0.48	14.7	0.66	16.3	0.55	17.0	0.45		
62	11.8	0.30	13.2	0.43	15.5	0.57	17.0	0.45				
60	12.4	0.27	13.8	0.40	16.0	0.50	17.3	0.35				
57					16.7	0.43	17.8	0.25				
A(°)			35~82				45~82		60~82		75~82	

ジブオフセット	7°		15°		30°		45°		60°		75°	
ブーム角度 (°)	作業半径 (m)	定格総荷重 (t)	作業半径 (m)	定格総荷重 (t)	作業半径 (m)	定格総荷重 (t)	作業半径 (m)	定格総荷重 (t)	作業半径 (m)	定格総荷重 (t)	作業半径 (m)	定格総荷重 (t)
82	5.5	0.65	7.5	0.65	11.1	0.40	13.9	0.30	15.9	0.27	16.8	0.27
80	6.3	0.65	8.3	0.65	11.8	0.40	14.5	0.30	16.4	0.27	17.2	0.27
78	7.1	0.65	9.1	0.65	12.5	0.40	15.1	0.30	16.8	0.27		
74	8.7	0.60	10.6	0.56	13.9	0.38	16.3	0.30	17.7	0.27		
72	9.5	0.50	11.4	0.53	14.5	0.37	16.8	0.30	18.1	0.27		
70	10.3	0.40	12.1	0.50	15.2	0.35	17.3	0.30	18.5	0.27		
67	11.4	0.33	13.2	0.44	16.1	0.34	18.1	0.29	19.0	0.27		
65	12.2	0.29	13.9	0.40	16.7	0.33	18.5	0.28				
62	13.2	0.24	14.9	0.35	17.5	0.31	19.2	0.28				
60	13.9	0.21	15.5	0.32	18.0	0.30	19.6	0.27				
57					18.8	0.28	20.1	0.27				
A(°)			45~82				50~82		60~82		75~82	

A: ブーム角度の範囲 (無負荷時)

5.5mブーム+4.1mジブ												
ジブオフセット	※7°		※15°		30°		45°		60°		75°	
ブーム角度 (°)	作業半径 (m)	定格総荷重 (t)	作業半径 (m)	定格総荷重 (t)	作業半径 (m)	定格総荷重 (t)	作業半径 (m)	定格総荷重 (t)	作業半径 (m)	定格総荷重 (t)	作業半径 (m)	定格総荷重 (t)
82	1.8	1.80	2.5	1.80	3.0	1.80	3.8	1.80	4.3	1.80	4.6	1.80
80	2.2	1.80	2.8	1.80	3.3	1.80	4.0	1.80	4.5	1.80	4.8	1.80
78	2.6	1.80	3.2	1.80	3.6	1.80	4.3	1.80	4.8	1.80	4.9	1.80
74	3.3	1.80	3.9	1.80	4.2	1.80	4.8	1.80	5.2	1.80		
72	3.6	1.80	4.2	1.80	4.5	1.80	5.1	1.80	5.4	1.80		
70	3.9	1.80	4.5	1.80	4.7	1.80	5.3	1.80	5.6	1.80		
67	4.4	1.70	4.9	1.75	5.1	1.80	5.6	1.80	5.9	1.80		
65	4.7	1.65	5.2	1.70	5.4	1.80	5.8	1.80	6.1	1.80		
62	5.2	1.60	5.7	1.65	5.7	1.80	6.1	1.80				
60	5.5	1.55	6.0	1.60	5.9	1.80	6.3	1.80				
57	5.9	1.50	6.4	1.55	6.3	1.80	6.6	1.80				
55	6.1	1.45	6.6	1.55	6.5	1.80	6.8	1.80				
52	6.5	1.40	7.0	1.50	6.8	1.80	7.0	1.80				
50	6.8	1.40			6.9	1.80						
A(°)	7~82		15~82		30~82		45~82		60~82		75~82	

5.5mブーム+6.5mジブ												
ジブオフセット	7°		15°		30°		45°		60°		75°	
ブーム角度 (°)	作業半径 (m)	定格総荷重 (t)	作業半径 (m)	定格総荷重 (t)	作業半径 (m)	定格総荷重 (t)	作業半径 (m)	定格総荷重 (t)	作業半径 (m)	定格総荷重 (t)	作業半径 (m)	定格総荷重 (t)
82	2.3	1.80	3.1	1.80	4.6	1.80	5.8	1.80	6.6	1.80	7.0	1.80
80	2.7	1.80	3.5	1.80	4.9	1.80	6.1	1.80	6.8	1.80	7.2	1.80
78	3.1	1.80	3.9	1.80	5.3	1.80	6.4	1.80	7.1	1.80	7.4	1.80
74	3.9	1.80	4.6	1.80	6.0	1.80	7.0	1.80	7.6	1.80		
72	4.2	1.80	5.0	1.80	6.3	1.80	7.3	1.80	7.8	1.80		
70	4.6	1.80	5.4	1.80	6.6	1.80	7.5	1.80	8.0	1.80		
67	5.2	1.55	5.9	1.65	7.1	1.80	7.9	1.80				
65	5.5	1.40	6.2	1.55	7.4	1.80	8.2	1.75				
62	6.0	1.20	6.7	1.40	7.8	1.80	8.5	1.70				
60	6.4	1.10	7.0	1.35	8.1	1.80	8.7	1.65				
57	6.9	1.00	7.5	1.25	8.5	1.70	9.0	1.60				
55	7.2	0.90	7.8	1.20	8.7	1.65						
52	7.9	0.80	8.2	1.10	9.0	1.55						
50			8.5	1.05	9.3	1.45						
A(°)	7~82		15~82		30~82		45~82		60~82		75~82	

5.5mブーム+8.9mジブ												
ジブオフセット	7°		15°		30°		45°		60°		75°	
ブーム角度 (°)	作業半径 (m)	定格総荷重 (t)	作業半径 (m)	定格総荷重 (t)	作業半径 (m)	定格総荷重 (t)	作業半径 (m)	定格総荷重 (t)	作業半径 (m)	定格総荷重 (t)	作業半径 (m)	定格総荷重 (t)
82	3.0	1.20	4.1	1.20	6.1	1.20	7.7	1.20	8.8	1.20	9.3	1.20
80	3.4	1.20	4.6	1.20	6.5	1.20	8.1	1.20	9.1	1.20	9.6	1.20
78	3.9	1.20	5.0	1.20	6.9	1.20	8.4	1.20	9.4	1.20		
74	4.8	1.20	5.9	1.20	7.7	1.20	9.1	1.20	9.9	1.20		
72	5.3	1.20	6.4	1.20	8.1	1.20	9.4	1.20	10.2	1.20		
70	5.8	1.05	6.8	1.15	8.5	1.20	9.7	1.20	10.4	1.20		
67	6.4	0.90	7.4	1.05	9.0	1.20	10.2	1.20	10.7	1.20		
65	6.8	0.78	7.8	0.97	9.4	1.20	10.5	1.20	10.9	1.20		
62	7.5	0.68	8.4	0.85	9.9	1.15	10.8	1.20				
60	7.9	0.63	8.8	0.80	10.2	1.10	11.1	1.20				
57	8.4	0.53	9.3	0.72	10.6	1.05	11.4	1.10				
55	8.8	0.48	9.7	0.68	10.9	1.00	11.6	1.05				
52	9.4	0.42	10.1	0.63	11.3	0.97	11.9	1.00				
50	9.7	0.38	10.5	0.60	11.5	0.94	12.0	0.95				
A(°)	7~82		15~82		30~82		45~82		60~82		75~82	

5.5mブーム+13.6mジブ												
ジブオフセット	7°		15°		30°		45°		60°		75°	
ブーム角度 (°)	作業半径 (m)	定格総荷重 (t)	作業半径 (m)	定格総荷重 (t)	作業半径 (m)	定格総荷重 (t)	作業半径 (m)	定格総荷重 (t)	作業半径 (m)	定格総荷重 (t)	作業半径 (m)	定格総荷重 (t)
82	4.3	0.70	6.0	0.70	9.1	0.70	11.6	0.68	13.2	0.55	14.0	0.55
80	4.9	0.70	6.7	0.70	9.7	0.70	12.0	0.68	13.6	0.55	14.3	0.55
78	5.6	0.70	7.3	0.70	10.2	0.70	12.5	0.66	13.9	0.55	14.5	0.55
74	6.8	0.70	8.4	0.70	11.2	0.70	13.3	0.64	14.5	0.55		
72	7.4	0.65	9.0	0.70	11.7	0.70	13.7	0.63	14.8	0.55		
70	8.0	0.55	9.6	0.65	12.2	0.70	14.1	0.62	15.1	0.55		
67	8.9	0.45	10.4	0.55	12.9	0.70	14.6	0.61				
65	9.4	0.40	10.9	0.50	13.3	0.68	15.0	0.60				
62	10.3	0.33	11.7	0.43	14.0	0.65	15.4	0.58				
60	10.8	0.27	12.2	0.39	14.4	0.63	15.7	0.57				
57			12.9	0.35	14.9	0.60	16.1	0.56				
A(°)	35~82		15~82		30~82		45~82		60~82		75~82	

5.5mブーム+15.9mジブ												
ジブオフセット	7°		15°		30°		45°		60°		75°	
ブーム角度 (°)	作業半径 (m)	定格総荷重 (t)	作業半径 (m)	定格総荷重 (t)	作業半径 (m)	定格総荷重 (t)	作業半径 (m)	定格総荷重 (t)	作業半径 (m)	定格総荷重 (t)	作業半径 (m)	定格総荷重 (t)
82	5.0	0.65	7.0	0.65	10.6	0.40	13.4	0.30	15.4	0.27	16.3	0.27
80	5.7	0.65	7.7	0.65	11.2	0.40	13.9	0.30	15.8	0.27	16.5	0.27
78	6.4	0.65	8.4	0.65	11.8	0.40	14.4	0.30	16.1	0.27		
74	7.8	0.55	9.7	0.56	12.9	0.38	15.4	0.30	16.8	0.27		
72	8.5	0.50	10.4	0.53	13.5	0.37	15.8	0.29	17.1	0.27		
70	9.1	0.43	11.0	0.50	14.0	0.36	16.2	0.29	17.4	0.27		
67	10.1	0.35	11.9	0.45	14.8	0.34	16.8	0.28	17.7	0.27		
65	10.8	0.30	12.5	0.40	15.3	0.33	17.1	0.28	18.0	0.27		
62	11.7	0.25	13.4	0.33	16.0	0.32	17.6	0.27				
60			13.9	0.30	16.4	0.31	17.9	0.27				
A(°)	45~82		35~82		30~82		45~82		60~82		75~82	

A: ブーム角度の範囲 (無負荷時)

■ 定格総荷重表 [補巻作業] アウトリガ中間張出 (2.5m) -側方-

※は5.0mジブ状態を示します。

15.0mブーム+4.1mジブ													
ジブオフセット	※7°		※15°		30°		45°		60°		75°		
ブーム角度 (°)	作業半径 (m)	定格総荷重 (t)	作業半径 (m)	定格総荷重 (t)	作業半径 (m)	定格総荷重 (t)	作業半径 (m)	定格総荷重 (t)	作業半径 (m)	定格総荷重 (t)	作業半径 (m)	定格総荷重 (t)	
82	3.3	1.80	4.0	1.80	4.6	1.80	5.4	1.80	5.9	1.25	6.1	1.25	
80	4.0	1.80	4.7	1.80	5.3	1.80	6.0	1.60	6.4	1.25	6.6	1.25	
78	4.8	1.80	5.3	1.70	5.9	1.65	6.6	1.40	7.0	1.25	7.1	1.25	
74	6.1	1.25	6.7	1.10	7.1	1.00	7.7	0.85	8.1	0.75			
72	6.8	0.95	7.4	0.80	7.7	0.80	8.2	0.65	8.6	0.60			
70	7.5	0.70	8.0	0.60	8.2	0.55	8.8	0.45	9.1	0.40			
67					9.1	0.25							
A(°)	62~82				65~82				67~82				75~82

15.0mブーム+6.5mジブ													
ジブオフセット	7°		15°		30°		45°		60°		75°		
ブーム角度 (°)	作業半径 (m)	定格総荷重 (t)	作業半径 (m)	定格総荷重 (t)	作業半径 (m)	定格総荷重 (t)	作業半径 (m)	定格総荷重 (t)	作業半径 (m)	定格総荷重 (t)	作業半径 (m)	定格総荷重 (t)	
82	4.0	1.80	4.8	1.80	6.3	1.35	7.5	1.05	8.3	0.80	8.6	0.85	
80	4.7	1.80	5.6	1.80	7.0	1.35	8.1	1.05	8.8	0.80	9.1	0.85	
78	5.5	1.80	6.3	1.50	7.7	1.00	8.8	0.75	9.4	0.65	9.6	0.65	
74	6.9	1.05	7.7	0.80	9.0	0.60	10.0	0.45	10.5	0.35			
72	7.6	0.75	8.3	0.55	9.6	0.40	10.6	0.30	11.1	0.25			
70	8.2	0.50	9.0	0.40			11.2	0.20					
67	9.2	0.25											
A(°)	65~82				67~82				70~82				75~82

15.0mブーム+8.9mジブ													
ジブオフセット	7°		15°		30°		45°		60°		75°		
ブーム角度 (°)	作業半径 (m)	定格総荷重 (t)	作業半径 (m)	定格総荷重 (t)	作業半径 (m)	定格総荷重 (t)	作業半径 (m)	定格総荷重 (t)	作業半径 (m)	定格総荷重 (t)	作業半径 (m)	定格総荷重 (t)	
82	4.7	1.20	5.9	1.20	7.9	0.80	9.5	0.70	10.5	0.60	11.0	0.40	
80	5.5	1.20	6.7	1.20	8.7	0.80	10.2	0.70	11.2	0.60	11.5	0.40	
78	6.3	1.20	7.4	1.05	9.4	0.70	10.8	0.50	11.8	0.40	12.0	0.40	
74	7.8	0.80	9.0	0.60	10.8	0.25	12.2	0.20					
72	8.6	0.60	9.7	0.40									
70	9.4	0.40											
A(°)	67~82				70~82				72~82				75~82

15.0mブーム+13.6mジブ													
ジブオフセット	7°		15°		30°		45°		60°		75°		
ブーム角度 (°)	作業半径 (m)	定格総荷重 (t)	作業半径 (m)	定格総荷重 (t)	作業半径 (m)	定格総荷重 (t)	作業半径 (m)	定格総荷重 (t)	作業半径 (m)	定格総荷重 (t)	作業半径 (m)	定格総荷重 (t)	
82	6.1	0.70	7.9	0.70	11.0	0.55	13.4	0.40					
80	7.0	0.70	8.8	0.70	11.9	0.55	14.2	0.40					
78	8.0	0.70	9.7	0.65	12.7	0.45							
74	9.9	0.55	11.6	0.40									
A(°)	67~82				72~82				74~82				

15.0mブーム+15.9mジブ													
ジブオフセット	7°		15°		30°		45°		60°		75°		
ブーム角度 (°)	作業半径 (m)	定格総荷重 (t)	作業半径 (m)	定格総荷重 (t)	作業半径 (m)	定格総荷重 (t)	作業半径 (m)	定格総荷重 (t)	作業半径 (m)	定格総荷重 (t)	作業半径 (m)	定格総荷重 (t)	
82	6.8	0.65	8.8	0.65	12.3	0.40	15.1	0.30					
80	7.8	0.65	9.9	0.65	13.3	0.40	16.0	0.30					
78	8.9	0.65	10.9	0.60	14.2	0.35	16.8	0.20					
74	10.9	0.45	12.8	0.30									
72	11.9	0.30											
A(°)	67~82				70~82				72~82				74~82

A: ブーム角度の範囲 (無負荷時)

11.8mブーム+4.1mジブ													
ジブオフセット	※7°		※15°		30°		45°		60°		75°		
ブーム角度 (°)	作業半径 (m)	定格総荷重 (t)	作業半径 (m)	定格総荷重 (t)	作業半径 (m)	定格総荷重 (t)	作業半径 (m)	定格総荷重 (t)	作業半径 (m)	定格総荷重 (t)	作業半径 (m)	定格総荷重 (t)	
82	2.8	1.80	3.4	1.80	4.0	1.80	4.8	1.80	5.3	1.80	5.5	1.80	
80	3.4	1.80	3.9	1.80	4.5	1.80	5.3	1.80	5.7	1.80	5.9	1.80	
78	3.9	1.80	4.6	1.80	5.1	1.80	5.7	1.80	6.2	1.80			
74	5.1	1.80	5.7	1.65	6.0	1.60	6.7	1.30	7.0	1.20			
72	5.6	1.60	6.1	1.40	6.5	1.30	7.1	1.10	7.4	1.00			
70	6.1	1.30	6.7	1.15	7.0	1.05	7.6	0.90	7.9	0.80			
67	6.9	0.90	7.5	0.75	7.7	0.75	8.2	0.65	8.4	0.60			
65	7.5	0.70	8.0	0.60	8.1	0.60	8.6	0.50	8.8	0.45			
62	8.2	0.45	8.7	0.35	8.8	0.35	9.2	0.30					
60			9.2	0.25	9.2	0.25							
A(°)	55~82				57~82				60~82				75~82

11.8mブーム+6.5mジブ													
ジブオフセット	7°		15°		30°		45°		60°		75°		
ブーム角度 (°)	作業半径 (m)	定格総荷重 (t)	作業半径 (m)	定格総荷重 (t)	作業半径 (m)	定格総荷重 (t)	作業半径 (m)	定格総荷重 (t)	作業半径 (m)	定格総荷重 (t)	作業半径 (m)	定格総荷重 (t)	
82	3.3	1.80	4.2	1.80	5.6	1.80	6.8	1.50	7.6	1.15	8.0	0.85	
80	4.0	1.80	4.8	1.80	6.2	1.80	7.3	1.35	8.1	1.15	8.4	0.85	
78	4.6	1.80	5.4	1.80	6.8	1.45	7.9	1.10	8.6	0.95	8.8	0.85	
74	5.8	1.80	6.6	1.35	7.9	0.95	8.9	0.75	9.5	0.65			
72	6.4	1.30	7.1	1.05	8.4	0.75	9.4	0.60	9.9	0.50			
70	6.9	1.00	7.7	0.85	9.0	0.60	9.9	0.50	10.3	0.40			
67	7.8	0.70	8.5	0.55	9.7	0.40	10.5	0.30	10.9	0.30			
65	8.3	0.50	9.1	0.40	10.2	0.30	11.0	0.20					
62	9.2	0.30	9.9	0.25									
A(°)	57~82				60~82				62~82				75~82

11.8mブーム+8.9mジブ													
ジブオフセット	7°		15°		30°		45°		60°		75°		
ブーム角度 (°)	作業半径 (m)	定格総荷重 (t)	作業半径 (m)	定格総荷重 (t)	作業半径 (m)	定格総荷重 (t)	作業半径 (m)	定格総荷重 (t)	作業半径 (m)	定格総荷重 (t)	作業半径 (m)	定格総荷重 (t)	
82	4.0	1.20	5.2	1.20	7.2	1.15	8.8	1.00	9.9	0.60	10.3	0.60	
80	4.7	1.20	5.9	1.20	7.8	1.15	9.4	0.90	10.4	0.60	10.8	0.60	
78	5.4	1.20	6.5	1.20	8.5	1.00	9.9	0.75	10.9	0.60	11.2	0.60	
74	6.8	1.20	7.9	1.00	9.7	0.65	11.0	0.50	11.8	0.40			
72	7.4	1.00	8.5	0.80	10.3	0.50	11.6	0.40					
70	8.1	0.75	9.1	0.60	10.9	0.40	12.1	0.30					
67	9.0	0.55	10.1	0.40									
65	9.7	0.35	10.7	0.25									
A(°)	60~82		62~82		65~82				67~82				75~82

11.8mブーム+13.6mジブ													
ジブオフセット	7°		15°		30°		45°		60°		75°		
ブーム角度 (°)	作業半径 (m)	定格総荷重 (t)	作業半径 (m)	定格総荷重 (t)	作業半径 (m)	定格総荷重 (t)	作業半径 (m)	定格総荷重 (t)	作業半径 (m)	定格総荷重 (t)	作業半径 (m)	定格総荷重 (t)	
82	5.4	0.70	7.2	0.70	10.2	0.70	12.7	0.55					
80	6.2	0.70	8.0	0.70	11.0	0.70	13.4	0.55					
78	7.1	0.70	8.8	0.70	11.8	0.60	14.0	0.40					
74	8.7	0.70	10.4	0.70	13.2	0.35							
72	9.5	0.65	11.2	0.45									
70	10.3	0.55	12.0	0.35									
A(°)	62~82				65~82				67~82				

11.8mブーム+15.9mジブ													
ジブオフセット	7°		15°		30°		45°		60°		75°		
ブーム角度 (°)	作業半径 (m)	定格総荷重 (t)	作業半径 (m)	定格総荷重 (t)	作業半径 (m)	定格総荷重 (t)	作業半径 (m)	定格総荷重 (t)	作業半径 (m)	定格総荷重 (t)	作業半径 (m)	定格総荷重 (t)	
82	6.1	0.65	8.1	0.65	11.6	0.40	14.5	0.30					
80	7.0	0.65	9.0	0.65	12.5	0.40	15.2	0.30					
78	7.9	0.65	9.9	0.60	13.3	0.40	15.9	0.30					
74	9.8	0.57	11.7	0.52	14.9	0.30							
72	10.6	0.48	12.5	0.42									
70	11.5	0.40	13.4	0.30									
A(°)	62~82		65~82		67~82			72~82					

A: ブーム角度の範囲 (無負荷時)

ジブオフセット	※7°		※15°		30°		45°		60°		75°			
ブーム角度 (°)	作業半径 (m)	定格総荷重 (t)	作業半径 (m)	定格総荷重 (t)	作業半径 (m)	定格総荷重 (t)	作業半径 (m)	定格総荷重 (t)	作業半径 (m)	定格総荷重 (t)	作業半径 (m)	定格総荷重 (t)		
82	2.3	1.80	2.9	1.80	3.5	1.80	4.2	1.80	4.8	1.80	5.0	1.80		
80	2.8	1.80	3.4	1.80	3.9	1.80	4.6	1.80	5.1	1.80	5.3	1.80		
78	3.2	1.80	3.9	1.80	4.3	1.80	5.0	1.80	5.4	1.80	5.6	1.80		
74	4.1	1.80	4.7	1.80	5.1	1.80	5.7	1.80	6.1	1.80				
72	4.6	1.80	5.2	1.75	5.5	1.80	6.1	1.65	6.4	1.55				
70	5.0	1.80	5.6	1.65	5.8	1.65	6.4	1.45	6.7	1.35				
67	5.6	1.60	6.2	1.40	6.4	1.35	6.9	1.15	7.1	1.10				
65	6.1	1.40	6.6	1.25	6.7	1.15	7.2	1.00						
62	6.7	1.10	7.2	0.95	7.2	0.90	7.7	0.85						
60	7.1	0.95	7.6	0.80	7.5	0.75	7.9	0.70						
57	7.7	0.70	8.1	0.65	8.0	0.60	8.4	0.55						
55	8.0	0.55	8.5	0.55	8.3	0.50	8.6	0.45						
52			9.0	0.30	8.7	0.35	9.0	0.30						
50					9.0	0.25								
A(°)			40~82				45~82				60~82		75~82	

ジブオフセット	7°		15°		30°		45°		60°		75°	
ブーム角度 (°)	作業半径 (m)	定格総荷重 (t)	作業半径 (m)	定格総荷重 (t)	作業半径 (m)	定格総荷重 (t)	作業半径 (m)	定格総荷重 (t)	作業半径 (m)	定格総荷重 (t)	作業半径 (m)	定格総荷重 (t)
82	2.8	1.80	3.6	1.80	5.1	1.80	6.2	1.50	7.1	1.15	7.4	1.20
80	3.3	1.80	4.1	1.80	5.5	1.80	6.7	1.50	7.4	1.15	7.8	1.20
78	3.8	1.80	4.6	1.80	6.0	1.80	7.1	1.50	7.8	1.15	8.1	1.20
74	4.8	1.80	5.6	1.80	6.9	1.40	7.9	1.10	8.5	1.00		
72	5.3	1.80	6.0	1.70	7.3	1.20	8.3	0.95	8.8	0.85		
70	5.7	1.80	6.5	1.40	7.8	1.00	8.7	0.80	9.1	0.75		
67	6.4	1.30	7.2	1.05	8.4	0.80	9.2	0.65	9.6	0.60		
65	6.9	1.10	7.6	0.90	8.8	0.70	9.5	0.55	9.9	0.50		
62	7.6	0.85	8.3	0.70	9.3	0.50	10.0	0.45				
60	8.0	0.70	8.7	0.60	9.7	0.40						
57	8.6	0.50	9.3	0.45	10.2	0.30						
55	9.0	0.40	9.6	0.35								
A(°)	45~82			50~82				60~82			75~82	

ジブオフセット	7°		15°		30°		45°		60°		75°			
ブーム角度 (°)	作業半径 (m)	定格総荷重 (t)	作業半径 (m)	定格総荷重 (t)	作業半径 (m)	定格総荷重 (t)	作業半径 (m)	定格総荷重 (t)	作業半径 (m)	定格総荷重 (t)	作業半径 (m)	定格総荷重 (t)		
82	3.4	1.20	4.6	1.20	6.6	1.20	8.2	1.00	9.3	0.85	9.8	0.90		
80	4.0	1.20	5.2	1.20	7.1	1.20	8.7	1.00	9.7	0.85	10.2	0.90		
78	4.6	1.20	5.7	1.20	7.7	1.20	9.2	1.00	10.1	0.80				
74	5.8	1.20	6.8	1.20	8.7	0.95	10.0	0.75	10.8	0.60				
72	6.3	1.20	7.4	1.20	9.2	0.80	10.5	0.63	11.2	0.52				
70	6.9	1.00	7.9	1.00	9.6	0.70	10.9	0.53	11.5	0.45				
67	7.7	0.85	8.7	0.80	10.3	0.55	11.5	0.40	12.0	0.35				
65	8.2	0.75	9.2	0.65	10.8	0.45	11.8	0.33						
62	9.0	0.60	9.9	0.45	11.4	0.30								
60	9.5	0.45	10.4	0.35	11.8	0.23								
57	10.2	0.30	11.1	0.23										
A(°)	50~82			52~82				57~82			60~82		75~82	

ジブオフセット	7°		15°		30°		45°		60°		75°	
ブーム角度 (°)	作業半径 (m)	定格総荷重 (t)	作業半径 (m)	定格総荷重 (t)	作業半径 (m)	定格総荷重 (t)	作業半径 (m)	定格総荷重 (t)	作業半径 (m)	定格総荷重 (t)	作業半径 (m)	定格総荷重 (t)
82	4.8	0.70	6.5	0.70	9.6	0.70	12.1	0.60				
80	5.5	0.70	7.3	0.70	10.3	0.70	12.6	0.60				
78	6.3	0.70	8.0	0.70	10.9	0.70	13.2	0.60				
74	7.7	0.70	9.4	0.70	12.2	0.57						
72	8.4	0.63	10.1	0.70	12.8	0.50						
70	9.1	0.53	10.7	0.62								
67	10.2	0.43	11.7	0.45								
65	10.8	0.35										
62	11.8	0.30										
A(°)	55~82				57~82				60~82			

ジブオフセット	7°		15°		30°		45°		60°		75°	
ブーム角度 (°)	作業半径 (m)	定格総荷重 (t)	作業半径 (m)	定格総荷重 (t)	作業半径 (m)	定格総荷重 (t)	作業半径 (m)	定格総荷重 (t)	作業半径 (m)	定格総荷重 (t)	作業半径 (m)	定格総荷重 (t)
82	5.5	0.65	7.5	0.65	11.1	0.40	13.9	0.30				
80	6.3	0.65	8.3	0.65	11.8	0.40	14.5	0.30				
78	7.1	0.65	9.1	0.65	12.5	0.40	15.1	0.30				
74	8.7	0.60	10.6	0.56	13.9	0.38	16.3	0.30				
72	9.5	0.50	11.4	0.53	14.5	0.35	16.8	0.30				
70	10.3	0.40	12.1	0.50	15.2	0.30						
67	11.4	0.33	13.2	0.37								
65	12.2	0.29	13.9	0.30								
62	13.2	0.24										
A(°)	55~82			57~82			62~82			70~82		

A: ブーム角度の範囲 (無負荷時)

5.5mブーム+4.1mジブ												
ジブオフセット	※7°		※15°		30°		45°		60°		75°	
ブーム角度 (°)	作業半径 (m)	定格総荷重 (t)	作業半径 (m)	定格総荷重 (t)	作業半径 (m)	定格総荷重 (t)	作業半径 (m)	定格総荷重 (t)	作業半径 (m)	定格総荷重 (t)	作業半径 (m)	定格総荷重 (t)
82	1.8	1.80	2.5	1.80	3.0	1.80	3.8	1.80	4.3	1.80	4.6	1.80
80	2.2	1.80	2.8	1.80	3.3	1.80	4.0	1.80	4.5	1.80	4.8	1.80
78	2.6	1.80	3.2	1.80	3.6	1.80	4.3	1.80	4.8	1.80	4.9	1.80
74	3.3	1.80	3.9	1.80	4.2	1.80	4.8	1.80	5.2	1.80		
72	3.6	1.80	4.2	1.80	4.5	1.80	5.1	1.80	5.4	1.80		
70	3.9	1.80	4.5	1.80	4.7	1.80	5.3	1.80	5.6	1.80		
67	4.4	1.70	4.9	1.75	5.1	1.80	5.6	1.80	5.9	1.80		
65	4.7	1.65	5.2	1.70	5.4	1.80	5.8	1.80	6.1	1.80		
62	5.2	1.60	5.7	1.65	5.7	1.80	6.1	1.70				
60	5.5	1.55	6.0	1.65	5.9	1.80	6.3	1.60				
57	5.9	1.50	6.4	1.55	6.3	1.55	6.6	1.45				
55	6.1	1.45	6.6	1.45	6.5	1.45	6.8	1.35				
52	6.5	1.30	7.0	1.25	6.8	1.30	7.0	1.20				
50	6.8	1.20			6.9	1.20						
A(°)	7~82		15~82		30~82		45~82		60~82		75~82	

5.5mブーム+6.5mジブ												
ジブオフセット	7°		15°		30°		45°		60°		75°	
ブーム角度 (°)	作業半径 (m)	定格総荷重 (t)	作業半径 (m)	定格総荷重 (t)	作業半径 (m)	定格総荷重 (t)	作業半径 (m)	定格総荷重 (t)	作業半径 (m)	定格総荷重 (t)	作業半径 (m)	定格総荷重 (t)
82	2.3	1.80	3.1	1.80	4.6	1.80	5.8	1.80	6.6	1.70	7.0	1.45
80	2.7	1.80	3.5	1.80	4.9	1.80	6.1	1.80	6.8	1.70	7.2	1.45
78	3.1	1.80	3.9	1.80	5.3	1.80	6.4	1.80	7.1	1.70	7.4	1.45
74	3.9	1.80	4.6	1.80	6.0	1.80	7.0	1.60	7.6	1.40		
72	4.2	1.80	5.0	1.80	6.3	1.70	7.3	1.50	7.8	1.30		
70	4.6	1.80	5.4	1.80	6.6	1.60	7.5	1.35	8.0	1.20		
67	5.2	1.50	5.9	1.65	7.1	1.45	7.9	1.20				
65	5.5	1.35	6.2	1.55	7.4	1.30	8.2	1.10				
62	6.0	1.20	6.7	1.45	7.8	1.15	8.5	0.98				
60	6.4	1.10	7.0	1.35	8.1	1.00	8.7	0.90				
57	6.9	0.97	7.5	1.15	8.5	0.90	9.0	0.80				
55	7.2	0.90	7.8	1.00	8.7	0.85						
52	7.9	0.80	8.2	0.85	9.0	0.75						
50			8.5	0.80	9.3	0.70						
A(°)	7~82		15~82		30~82		45~82		60~82		75~82	

5.5mブーム+8.9mジブ												
ジブオフセット	7°		15°		30°		45°		60°		75°	
ブーム角度 (°)	作業半径 (m)	定格総荷重 (t)	作業半径 (m)	定格総荷重 (t)	作業半径 (m)	定格総荷重 (t)	作業半径 (m)	定格総荷重 (t)	作業半径 (m)	定格総荷重 (t)	作業半径 (m)	定格総荷重 (t)
82	3.0	1.20	4.1	1.20	6.1	1.20	7.7	1.20	8.8	1.20	9.3	0.90
80	3.4	1.20	4.6	1.20	6.5	1.20	8.1	1.20	9.1	1.20	9.6	0.90
78	3.9	1.20	5.0	1.20	6.9	1.20	8.4	1.20	9.4	1.10		
74	4.8	1.20	5.9	1.20	7.7	1.20	9.1	1.05	9.9	0.90		
72	5.3	1.20	6.4	1.20	8.1	1.20	9.4	0.95	10.2	0.85		
70	5.8	1.05	6.8	1.15	8.5	1.10	9.7	0.85	10.4	0.80		
67	6.4	0.90	7.4	1.05	9.0	1.00	10.2	0.75	10.7	0.70		
65	6.8	0.78	7.8	0.97	9.4	0.90	10.5	0.70	10.9	0.65		
62	7.5	0.68	8.4	0.85	9.9	0.80	10.8	0.65	11.2	0.55		
60	7.9	0.63	8.8	0.80	10.2	0.70	11.1	0.60				
57	8.4	0.53	9.3	0.72	10.6	0.60	11.4	0.55				
55	8.8	0.48	9.7	0.68	10.9	0.55	11.6	0.50				
52	9.4	0.42	10.1	0.62	11.3	0.50	11.9	0.45				
50	9.7	0.38	10.5	0.55	11.5	0.45	12.0	0.40				
A(°)	30~82		25~82		30~82		45~82		60~82		75~82	

5.5mブーム+13.6mジブ												
ジブオフセット	7°		15°		30°		45°		60°		75°	
ブーム角度 (°)	作業半径 (m)	定格総荷重 (t)	作業半径 (m)	定格総荷重 (t)	作業半径 (m)	定格総荷重 (t)	作業半径 (m)	定格総荷重 (t)	作業半径 (m)	定格総荷重 (t)	作業半径 (m)	定格総荷重 (t)
82	4.3	0.70	6.0	0.70	9.1	0.70	11.6	0.68				
80	4.9	0.70	6.7	0.70	9.7	0.70	12.0	0.68				
78	5.6	0.70	7.3	0.70	10.2	0.70	12.5	0.68				
74	6.8	0.70	8.4	0.70	11.2	0.70	13.3	0.60				
72	7.4	0.65	9.0	0.70	11.7	0.70	13.7	0.54				
70	8.0	0.55	9.6	0.65	12.2	0.70	14.1	0.48				
67	8.9	0.45	10.4	0.55	12.9	0.55	14.6	0.43				
65	9.4	0.40	10.9	0.50	13.3	0.50	15.0	0.40				
62	10.3	0.33	11.7	0.43	14.0	0.40						
60	10.8	0.27	12.2	0.39	14.4	0.35						
57			12.9	0.35	14.9	0.30						
A(°)	45~82		45~82		40~82		45~82					

5.5mブーム+15.9mジブ												
ジブオフセット	7°		15°		30°		45°		60°		75°	
ブーム角度 (°)	作業半径 (m)	定格総荷重 (t)	作業半径 (m)	定格総荷重 (t)	作業半径 (m)	定格総荷重 (t)	作業半径 (m)	定格総荷重 (t)	作業半径 (m)	定格総荷重 (t)	作業半径 (m)	定格総荷重 (t)
82	5.0	0.65	7.0	0.65	10.6	0.40	13.4	0.30				
80	5.7	0.65	7.7	0.65	11.2	0.40	13.9	0.30				
78	6.4	0.65	8.4	0.65	11.8	0.40	14.4	0.30				
74	7.8	0.55	9.7	0.56	12.9	0.38	15.4	0.30				
72	8.5	0.50	10.4	0.53	13.5	0.37	15.8	0.29				
70	9.1	0.43	11.0	0.50	14.0	0.36	16.2	0.29				
67	10.1	0.35	11.9	0.45	14.8	0.34	16.8	0.28				
65	10.8	0.30	12.5	0.40								
62	11.7	0.25	13.4	0.33								
60			13.9	0.30								
A(°)	52~82		55~82		55~82		65~82					

A: ブーム角度の範囲 (無負荷時)

■ 定格総荷重表 [補巻作業] アウトリガ最小張出 (1.64m) -側方-

※は5.0mジブ状態を示します。

15.0mブーム+4.1mジブ												
ジブオフセット	※7°		※15°		30°		45°		60°		75°	
ブーム角度 (°)	作業半径 (m)	定格総荷重 (t)	作業半径 (m)	定格総荷重 (t)	作業半径 (m)	定格総荷重 (t)	作業半径 (m)	定格総荷重 (t)	作業半径 (m)	定格総荷重 (t)	作業半径 (m)	定格総荷重 (t)
82	3.3	1.55	4.0	1.30	4.6	1.05	5.4	0.65	5.9	0.35	6.1	0.35
80	4.0	1.30	4.7	1.05	5.3	0.85	6.0	0.65	6.4	0.35	6.6	0.35
78	4.8	0.85	5.3	0.65	5.9	0.55			7.0	0.35		
A(°)	74~82						75~82					

15.0mブーム+6.5mジブ												
ジブオフセット	7°		15°		30°		45°		60°		75°	
ブーム角度 (°)	作業半径 (m)	定格総荷重 (t)	作業半径 (m)	定格総荷重 (t)	作業半径 (m)	定格総荷重 (t)	作業半径 (m)	定格総荷重 (t)	作業半径 (m)	定格総荷重 (t)	作業半径 (m)	定格総荷重 (t)
82	4.0	1.20	4.8	0.80								
80	4.7	1.05	5.6	0.75								
78	5.5	0.65										
A(°)	74~82											

A: ブーム角度の範囲 (無負荷時)

補巻作業

■ 定格総荷重表 [補巻作業] アウトリガ最小張出 (1.64m) -側方-

※は5.0mジブ状態を示します。

11.8mブーム+4.1mジブ												
ジブオフセット	※7°		※15°		30°		45°		60°		75°	
ブーム角度 (°)	作業半径 (m)	定格総荷重 (t)	作業半径 (m)	定格総荷重 (t)	作業半径 (m)	定格総荷重 (t)	作業半径 (m)	定格総荷重 (t)	作業半径 (m)	定格総荷重 (t)	作業半径 (m)	定格総荷重 (t)
82	2.8	1.70	3.4	1.65	4.0	1.40	4.8	1.20	5.3	1.00	5.5	0.75
80	3.4	1.70	3.9	1.60	4.5	1.40	5.3	1.10	5.7	0.90	5.9	0.75
78	3.9	1.55	4.6	1.20	5.1	1.00	5.7	0.80	6.2	0.70		
74	5.1	0.80	5.7	0.55	6.0	0.50						
72	5.6	0.50	6.1	0.40								
A(°)	70~82		67~82		72~82		74~82		74~82		75~82	

11.8mブーム+6.5mジブ												
ジブオフセット	7°		15°		30°		45°		60°		75°	
ブーム角度 (°)	作業半径 (m)	定格総荷重 (t)	作業半径 (m)	定格総荷重 (t)	作業半径 (m)	定格総荷重 (t)	作業半径 (m)	定格総荷重 (t)	作業半径 (m)	定格総荷重 (t)	作業半径 (m)	定格総荷重 (t)
82	3.3	1.60	4.2	1.45	5.6	0.85	6.8	0.65				
80	4.0	1.60	4.8	1.30	6.2	0.80						
78	4.6	1.15	5.4	0.80	6.8	0.50						
74	5.8	0.50										
A(°)	70~82		72~82		74~82							

11.8mブーム+8.9mジブ												
ジブオフセット	7°		15°		30°		45°		60°		75°	
ブーム角度 (°)	作業半径 (m)	定格総荷重 (t)	作業半径 (m)	定格総荷重 (t)	作業半径 (m)	定格総荷重 (t)	作業半径 (m)	定格総荷重 (t)	作業半径 (m)	定格総荷重 (t)	作業半径 (m)	定格総荷重 (t)
82	4.0	1.20	5.2	1.05								
80	4.7	1.20	5.9	0.85								
78	5.4	0.90	6.5	0.60								
74	6.8	0.35										
A(°)	72~82											

11.8mブーム+13.6mジブ												
ジブオフセット	7°		15°		30°		45°		60°		75°	
ブーム角度 (°)	作業半径 (m)	定格総荷重 (t)	作業半径 (m)	定格総荷重 (t)	作業半径 (m)	定格総荷重 (t)	作業半径 (m)	定格総荷重 (t)	作業半径 (m)	定格総荷重 (t)	作業半径 (m)	定格総荷重 (t)
82	5.4	0.70	7.2	0.50								
80	6.2	0.70	8.0	0.50								
78	7.1	0.60										
A(°)	72~82		74~82									

11.8mブーム+15.9mジブ												
ジブオフセット	7°		15°		30°		45°		60°		75°	
ブーム角度 (°)	作業半径 (m)	定格総荷重 (t)	作業半径 (m)	定格総荷重 (t)	作業半径 (m)	定格総荷重 (t)	作業半径 (m)	定格総荷重 (t)	作業半径 (m)	定格総荷重 (t)	作業半径 (m)	定格総荷重 (t)
82	6.1	0.65	8.1	0.40								
80	7.0	0.65	9.0	0.40								
78	7.9	0.45										
A(°)	74~82											

A: ブーム角度の範囲 (無負荷時)

8.7mブーム+4.1mジブ												
ジブオフセット	※7°		※15°		30°		45°		60°		75°	
ブーム角度 (°)	作業半径 (m)	定格総荷重 (t)	作業半径 (m)	定格総荷重 (t)	作業半径 (m)	定格総荷重 (t)	作業半径 (m)	定格総荷重 (t)	作業半径 (m)	定格総荷重 (t)	作業半径 (m)	定格総荷重 (t)
82	2.3	1.80	2.9	1.80	3.5	1.80	4.2	1.60	4.8	1.35	5.0	1.05
80	2.8	1.80	3.4	1.80	3.9	1.80	4.6	1.50	5.1	1.30	5.3	1.05
78	3.2	1.80	3.9	1.70	4.3	1.60	5.0	1.25	5.4	1.10	5.6	1.00
74	4.1	1.55	4.7	1.15	5.1	1.00	5.7	0.80	6.1	0.70		
72	4.6	1.10	5.2	0.90	5.5	0.75	6.1	0.60	6.4	0.60		
70	5.0	0.85	5.6	0.70	5.8	0.60	6.4	0.50	6.7	0.40		
67							6.9	0.30				
A(°)	62~82				65~82				67~82		75~82	

8.7mブーム+6.5mジブ												
ジブオフセット	7°		15°		30°		45°		60°		75°	
ブーム角度 (°)	作業半径 (m)	定格総荷重 (t)	作業半径 (m)	定格総荷重 (t)	作業半径 (m)	定格総荷重 (t)	作業半径 (m)	定格総荷重 (t)	作業半径 (m)	定格総荷重 (t)	作業半径 (m)	定格総荷重 (t)
82	2.8	1.80	3.6	1.80	5.1	1.10	6.2	0.65				
80	3.3	1.80	4.1	1.80	5.5	1.10	6.7	0.65				
78	3.8	1.80	4.6	1.50	6.0	0.85	7.1	0.60				
74	4.8	1.20	5.6	0.80	6.9	0.50						
72	5.3	0.80	6.0	0.65								
70	5.7	0.60										
A(°)	62~82		65~82		67~82		72~82					

8.7mブーム+8.9mジブ												
ジブオフセット	7°		15°		30°		45°		60°		75°	
ブーム角度 (°)	作業半径 (m)	定格総荷重 (t)	作業半径 (m)	定格総荷重 (t)	作業半径 (m)	定格総荷重 (t)	作業半径 (m)	定格総荷重 (t)	作業半径 (m)	定格総荷重 (t)	作業半径 (m)	定格総荷重 (t)
82	3.4	1.20	4.6	1.20	6.6	0.75						
80	4.0	1.20	5.2	1.20	7.1	0.70						
78	4.6	1.20	5.7	1.00	7.7	0.55						
74	5.8	0.80	6.8	0.60								
72	6.3	0.60										
70	6.9	0.40										
A(°)	65~82		67~82		72~82							

8.7mブーム+13.6mジブ												
ジブオフセット	7°		15°		30°		45°		60°		75°	
ブーム角度 (°)	作業半径 (m)	定格総荷重 (t)	作業半径 (m)	定格総荷重 (t)	作業半径 (m)	定格総荷重 (t)	作業半径 (m)	定格総荷重 (t)	作業半径 (m)	定格総荷重 (t)	作業半径 (m)	定格総荷重 (t)
82	4.8	0.70	6.5	0.70								
80	5.5	0.70	7.3	0.70								
78	6.3	0.70	8.0	0.55								
74	7.7	0.45										
A(°)	67~82		72~82									

8.7mブーム+15.9mジブ												
ジブオフセット	7°		15°		30°		45°		60°		75°	
ブーム角度 (°)	作業半径 (m)	定格総荷重 (t)	作業半径 (m)	定格総荷重 (t)	作業半径 (m)	定格総荷重 (t)	作業半径 (m)	定格総荷重 (t)	作業半径 (m)	定格総荷重 (t)	作業半径 (m)	定格総荷重 (t)
82	5.5	0.65	7.5	0.65								
80	6.3	0.65	8.3	0.65								
78	7.1	0.65	9.1	0.50								
74	8.7	0.40										
A(°)	70~82		72~82									

A: ブーム角度の範囲 (無負荷時)

ジブオフセット	※7°		※15°		30°		45°		60°		75°	
ブーム角度 (°)	作業半径 (m)	定格総荷重 (t)	作業半径 (m)	定格総荷重 (t)	作業半径 (m)	定格総荷重 (t)	作業半径 (m)	定格総荷重 (t)	作業半径 (m)	定格総荷重 (t)	作業半径 (m)	定格総荷重 (t)
82	1.8	1.80	2.5	1.80	3.0	1.80	3.8	1.80	4.3	1.70	4.6	1.40
80	2.2	1.80	2.8	1.80	3.3	1.80	4.0	1.80	4.5	1.70	4.8	1.40
78	2.6	1.80	3.2	1.80	3.6	1.80	4.3	1.80	4.8	1.55	4.9	1.40
74	3.3	1.80	3.9	1.75	4.2	1.80	4.8	1.40	5.2	1.30		
72	3.6	1.75	4.2	1.60	4.5	1.55	5.1	1.30	5.4	1.15		
70	3.9	1.65	4.5	1.45	4.7	1.35	5.3	1.10	5.6	1.00		
67	4.4	1.50	4.9	1.15	5.1	1.15	5.6	0.90	5.9	0.85		
65	4.7	1.20	5.2	1.05	5.4	1.00	5.8	0.80	6.1	0.75		
62	5.2	0.95	5.7	0.80	5.7	0.80	6.1	0.70				
60	5.5	0.80	6.0	0.70	5.9	0.70	6.3	0.60				
57	5.9	0.65			6.3	0.60	6.6	0.50				
55	6.1	0.60			6.5	0.50	6.8	0.45				
52					6.8	0.40	7.0	0.35				
50					6.9	0.35						
A(°)	50~82		40~82		45~82		50~82		60~82		75~82	

ジブオフセット	7°		15°		30°		45°		60°		75°	
ブーム角度 (°)	作業半径 (m)	定格総荷重 (t)	作業半径 (m)	定格総荷重 (t)	作業半径 (m)	定格総荷重 (t)	作業半径 (m)	定格総荷重 (t)	作業半径 (m)	定格総荷重 (t)	作業半径 (m)	定格総荷重 (t)
82	2.3	1.80	3.1	1.80	4.6	1.50	5.8	1.10	6.6	0.80	7.0	0.65
80	2.7	1.80	3.5	1.80	4.9	1.50	6.1	1.10	6.8	0.80	7.2	0.65
78	3.1	1.80	3.9	1.80	5.3	1.30	6.4	0.95	7.1	0.80	7.4	0.65
74	3.9	1.80	4.6	1.55	6.0	0.95	7.0	0.70	7.6	0.60		
72	4.2	1.65	5.0	1.30	6.3	0.85	7.3	0.65	7.8	0.50		
70	4.6	1.35	5.4	1.10	6.6	0.75	7.5	0.55	8.0	0.45		
67	5.2	1.05	5.9	0.80	7.1	0.60	7.9	0.40				
65	5.5	0.90	6.2	0.70								
62	6.0	0.70	6.7	0.55								
60	6.4	0.55	7.0	0.45								
57	6.9	0.40										
A(°)	55~82		57~82		60~82		65~82		75~82			

ジブオフセット	7°		15°		30°		45°		60°		75°	
ブーム角度 (°)	作業半径 (m)	定格総荷重 (t)	作業半径 (m)	定格総荷重 (t)	作業半径 (m)	定格総荷重 (t)	作業半径 (m)	定格総荷重 (t)	作業半径 (m)	定格総荷重 (t)	作業半径 (m)	定格総荷重 (t)
82	3.0	1.20	4.1	1.20	6.1	0.80	7.7	0.70	8.8	0.50	9.3	0.35
80	3.4	1.20	4.6	1.20	6.5	0.80	8.1	0.70	9.1	0.50	9.6	0.35
78	3.9	1.20	5.0	1.20	6.9	0.80	8.4	0.60				
74	4.8	1.20	5.9	1.20	7.7	0.65	9.1	0.45				
72	5.3	1.20	6.4	0.90	8.1	0.55						
70	5.8	1.00	6.8	0.75	8.5	0.45						
67	6.4	0.80	7.4	0.60	9.0	0.35						
65	6.8	0.60	7.8	0.50								
62	7.5	0.50										
60	7.9	0.40										
A(°)	57~82		62~82		65~82		67~82		72~82		75~82	

ジブオフセット	7°		15°		30°		45°		60°		75°	
ブーム角度 (°)	作業半径 (m)	定格総荷重 (t)	作業半径 (m)	定格総荷重 (t)	作業半径 (m)	定格総荷重 (t)	作業半径 (m)	定格総荷重 (t)	作業半径 (m)	定格総荷重 (t)	作業半径 (m)	定格総荷重 (t)
82	4.3	0.70	6.0	0.70	9.1	0.50						
80	4.9	0.70	6.7	0.70	9.7	0.50						
78	5.6	0.70	7.3	0.70	10.2	0.50						
74	6.8	0.70	8.4	0.70								
72	7.4	0.63	9.0	0.50								
70	8.0	0.55	9.6	0.40								
67	8.9	0.40										
65	9.4	0.35										
A(°)	62~82		67~82		70~82							

ジブオフセット	7°		15°		30°		45°		60°		75°	
ブーム角度 (°)	作業半径 (m)	定格総荷重 (t)	作業半径 (m)	定格総荷重 (t)	作業半径 (m)	定格総荷重 (t)	作業半径 (m)	定格総荷重 (t)	作業半径 (m)	定格総荷重 (t)	作業半径 (m)	定格総荷重 (t)
82	5.0	0.65	7.0	0.65	10.6	0.40						
80	5.7	0.65	7.7	0.65	11.2	0.40						
78	6.4	0.65	8.4	0.65	11.8	0.40						
74	7.8	0.55	9.7	0.50								
72	8.5	0.50	10.4	0.40								
70	9.1	0.40	11.0	0.30								
A(°)	65~82		67~82		72~82							

A: ブーム角度の範囲 (無負荷時)

(注意)

1. 定格総荷重は、水平堅土上においてクレーンを水平に設置した状態での値で、つり具と補巻フック質量 (25kg) を含んだ値です。太線より上はクレーンの強度によって定められ、下はクレーンの安定度によって定められています。
2. ブームの角度を基準にしてください。なお、作業半径は、ブームのたわみを含んだ参考値を示します。
3. 補巻作業におけるフックのワイヤー標準巻掛本数は1本です。
4. 側方域でのつり上げ性能は、アウトリガ張出幅によって異なります。張出幅に応じた性能で作業をしてください。また、前方・後方域でのつり上げ性能は「アウトリガ最大張出」の定格総荷重ですが、アウトリガ張出幅によってその前方・後方域の範囲(角度 a)が異なります。

張出幅	中間張出 (4.3m)	中間張出 (3.5m)	中間張出 (2.5m)	最小張出 (1.64m)
角度 a°	35	25	15	5

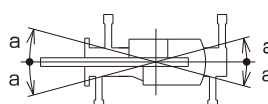

補巻作業

型式呼称	仕様	スペック番号
GR-130F	4.9t吊 4段ブーム 6段フルオートジブ H型アウトリガ、タイヤ 275/80R22.5 仕様	GR-130F-1-00101
GR-130F	4.9t吊 4段ブーム 6段フルオートジブ H型アウトリガ、タイヤ 295/80R22.5 仕様	GR-130F-1-00102

※お届けいたします製品は、改良などのため、この仕様書と相違する場合がありますのでご了承ください。