



Lifting your dreams

# GR-130F (I)

〔タワーリーチ式〕

(4段ブーム、6段フルオートジブ、H型アウトリガ)



# INDEX

|                   |        |     |
|-------------------|--------|-----|
| ■ 主要諸元            | .....  | P 1 |
| ■ 主要寸法図           | .....  | P 2 |
| ■ 外観図・最小直角通路幅     | .....  | P 3 |
| ■ 作業半径・揚程図 (主巻作業) | .....  | P 4 |
|                   | (補巻作業) | P 5 |
| ■ 定格総荷重表 (主巻作業)   | .....  | P 6 |
|                   | (補巻作業) | P11 |

・ブーム長さ、ジブ長さ、アウトリガ張出幅の組合せによって次のように定格総荷重表を選定し該当ページを読み取ってください。

| 主巻作業     |     | 3.3m |      |       |       |
|----------|-----|------|------|-------|-------|
| アウトリガ張出幅 | ジブ  |      |      |       |       |
|          | ブーム | 5.5m | 8.7m | 11.8m | 15.0m |
| 4.7m     |     | 6P   | 6P   | 6P    | 6P    |
| 4.3m     |     | 7P   | 7P   | 7P    | 7P    |
| 3.5m     |     | 8P   | 8P   | 8P    | 8P    |
| 2.5m     |     | 9P   | 9P   | 9P    | 9P    |
| 1.64m    |     | 10P  | 10P  | 10P   | 10P   |

| 補巻作業     |     | 4.1m~15.9m |      |       |       |
|----------|-----|------------|------|-------|-------|
| アウトリガ張出幅 | ジブ  |            |      |       |       |
|          | ブーム | 5.5m       | 8.7m | 11.8m | 15.0m |
| 4.7m     |     | 14P        | 13P  | 12P   | 11P   |
| 4.3m     |     | 18P        | 17P  | 16P   | 15P   |
| 3.5m     |     | 22P        | 21P  | 20P   | 19P   |
| 2.5m     |     | 26P        | 25P  | 24P   | 23P   |
| 1.64m    |     | 29P        | 28P  | 27P   | 27P   |

## ■主要諸元

### ●クレーン

|                     |  |                            |                     |
|---------------------|--|----------------------------|---------------------|
| クレーン容量              | 主巻作業<br>3.3mジブ   | 5.5mブーム                    | 4,900kg × 82° (4本掛) |
|                     |  | 8.7mブーム                    | 4,300kg × 80° (4本掛) |
|                     |  | 11.8mブーム                   | 4,300kg × 80° (4本掛) |
|                     |  | 15.0mブーム                   | 4,300kg × 82° (4本掛) |
|                     | 補巻作業   | 4.1mジブ                     | 1,800kg × 70° (1本掛) |
|                     |  | 6.5mジブ                     | 1,800kg × 72° (1本掛) |
|                     |  | 8.9mジブ                     | 1,200kg × 72° (1本掛) |
|                     |  | 13.6mジブ                    | 700kg × 67° (1本掛)   |
|                     | 15.9mジブ  | 650kg × 78° (1本掛)          |                     |
| 最大地上揚程              | 主巻   | 19.0m                      |                     |
|                     | 補巻   | 30.7m                      |                     |
| 最大作業半径              | 主巻   | 13.0m                      |                     |
|                     | 補巻   | 23.0m                      |                     |
| ブーム長さ               | 5.5m~15.0m   |                            |                     |
| ブーム伸縮長さ             | 9.5m   |                            |                     |
| ブーム伸長速度             | 9.5m/45s   |                            |                     |
| ジブ長さ                | 4.1m~15.9m   |                            |                     |
| ジブ伸縮長さ              | 11.8m  |                            |                     |
| ジブ伸長速度              | 11.8m/30s  |                            |                     |
| 巻き上げ速度<br>(ローブスピード) | 主巻   | 115m/min(5層)               |                     |
|                     | 補巻   | 100m/min(3層)               |                     |
| フック巻き上げ速度           | 主巻   | 28.8m/min(4本掛)             |                     |
|                     | 補巻   | 100m/min(1本掛)              |                     |
| ブーム起伏角度             | -3°~82°  |                            |                     |
| ブーム上げ速度             | -3°~82°/40s  |                            |                     |
| ジブオフセット角度           | 7°~75°   |                            |                     |
| ジブ上げ速度              | 7°~75°/20s   |                            |                     |
| 旋回角度                | 360°連続   |                            |                     |
| 旋回速度                | 2.4min <sup>-1</sup> {rpm}   |                            |                     |
| ワイヤロープ              | 主巻   | 径11.2mm × 長さ105m 難燃性ワイヤロープ |                     |
|                     | 補巻   | 径11.2mm × 長さ66m 難燃性ワイヤロープ  |                     |
| ブーム形式               | 五角形4段油圧伸縮式(2段目順次、3-4段目同時)  |                            |                     |
| ブーム伸縮装置             | 複動油圧シリンダ直押し式2本、ワイヤロープ式伸縮装置1基   |                            |                     |
| ジブ形式                | ブーム横折格納式、五角形6段油圧伸縮式、(2-3段目順次、4-5-6段目同時)  |                            |                     |
| ジブ伸縮装置              | 複動油圧シリンダ直押し式3本、ワイヤロープ式伸縮装置2基   |                            |                     |
| 巻き上げ装置              | 油圧モータ駆動遊星歯車減速式、自動ブレーキ、シングルウインチ 2基、圧力補償付流量調整弁付  |                            |                     |
| ブーム起伏装置             | 複動油圧シリンダ直押し式1本、圧力補償付流量調整弁付   |                            |                     |
| ジブ起伏装置              | 複動油圧シリンダ直押し式1本、圧力補償付流量調整弁付   |                            |                     |
| 旋回装置                | 油圧モータ駆動遊星歯車減速式、ボールベアリング式、ネガティブブレーキ   |                            |                     |
| アウトリガ               | 全油圧式H型(フロート一体型)、スライド・ジャッキ各個操作装置付、張出幅:最大4.7m、中間4.3m、3.5m、2.5m、最小1.64m   |                            |                     |
| 操作方式                | 油圧パイロット操作式(フィンガーコントロール式)   |                            |                     |
| 作業時最大路面荷重           | 10.6t  |                            |                     |
| 動力取出方式              | P.T.O.湿式多板クラッチ式  |                            |                     |
| 油圧ポンプ               | 2連可変ピストンポンプ、2連ギヤポンプ  |                            |                     |
| 安全装置                | 過負荷防止装置(AML)、旋回自動停止装置、起伏緩停止機能、ジブオフセット緩停止機能、巻過防止装置、作業領域制御装置、アウトリガ張出幅検出装置、水準器、玉掛けロープはずれ止め、油圧安全弁、伸縮シリンダ油圧ロック装置、起伏シリンダ油圧ロック装置、ジブ伸縮シリンダ油圧ロック装置、ジブオフセットシリンダ油圧ロック装置、ジャッキシリンダ油圧ロック装置 |                            |                     |
| 付属装置                | 除湿機能付エアコン、作動油温度表示灯、FM・AMラジオ、オイルクーラー、視覚式ドラムインジケータ、操作ペダル…ISO配列の場合:伸縮用および補巻用 タダノ配列の場合:起伏用および伸縮用 テレマティクス用通信端末、燃料消費モニター、エコモード、作動油目詰まり警報装置、拡声器、AML外部表示灯                            |                            |                     |
| 付属品                 | 盤木(4枚)   |                            |                     |

### ●キャリヤ

|            |   |  |
|------------|---|--|
| 車名および型式    | タダノ YDR-T015  |  |
| エンジン       | 名称  | 日野 J05E<br>(過給機及び給気冷却器、DPF/尿素SCRシステム付)           |
|            | 形式  | 水冷4サイクル4気筒直接噴射式ディーゼルエンジン                         |
|            | 総排気量  | 5.123L   |
|            | 最高出力  | 129kW(175PS) / 2,500min <sup>-1</sup> {rpm}      |
|            | 最大トルク   | 540N·m(55.0kgf·m) / 1,600min <sup>-1</sup> {rpm} |
| トルクコンバータ形式 | 3要素1段(自動ロックアップ機構付)  |  |
| 変速機形式      | 自動及び手動変速式、パワーシフト式(湿式多板クラッチ)前進3段、後退1段(Hi,Lo付)  |  |
| 減速機形式      | まがり歯かさ歯車2段減速式   |  |
| 駆動方式       | 2輪駆動(4×2)・4輪駆動(4×4)切換式  |  |
| 前車軸方式      | 全浮動式  |  |
| 後車軸方式      | 全浮動式  |  |
| 懸架方式       | 前輪  | 縦置板ばね式   |
|            | 後輪  | 縦置板ばね式   |
| ステアリング形式   | 全油圧式パワーステアリング   |  |
| ブレーキ       | 主ブレーキ   | 空気油圧複合式ディスクブレーキ                                  |
|            | 駐車ブレーキ  | 機械式推進軸制動内部拡張式                                    |
|            | 補助ブレーキ  | 排気管開閉弁式排気ブレーキ<br>作業用補助制動装置                       |
| フレーム       | 箱型溶接構造  |  |
| バッテリー      | 12V-100Ah×2個(24V)   |  |
| 燃料タンク容量    | 189L  |  |
| 尿素水タンク容量   | 19L   |  |
| タイヤ        | GR-130F-1-00101<br>前輪・後輪: 275/80R22.5 151/148J  |  |
|            | GR-130F-1-00102<br>前輪・後輪: 295/80R22.5 153/150J  |  |
| 運転室        | 乗車定員1人、内装付、ゴムマウント方式、フルアジャスタブル・サスペンションシート(ヘッドレスト、アームレスト、シートベルト付)、アジャスト式ハンドル(チルト、伸縮)、間欠式フロント・天井ワイパ(ウォッシュ付)、パワウインド、サイドバイザー |  |
| 安全装置       | 緊急かじ取装置、サスペンションロック装置、リヤステアリングロック装置、エンジンオーバーラン警報装置、オーバシフト防止装置、駐車ブレーキ警報装置、ラジエータ液面警報装置、作動油漏れ警報装置、前方および左前方カメラ               |  |
| 付属装置       | 手動式集中給油装置、ヒータ付電動格納ミラー、タイヤ歯止め、LEDヘッドランプ、人物検知警報装置、後方監視カメラ   |  |

### ●オプション

|  |
|--|
| 電動式集中給油装置、路肩灯、マーカーランプ、外部音声警報装置、ハロゲンヘッドランプ、盗難防止装置 |
|--|

| 走行時寸法 | GR-130F-1-00101 | GR-130F-1-00102 |
|-------|-----------------|-----------------|
| 全長    | 7,590mm         | 7,590mm         |
| 全幅    | 2,000mm         | 2,000mm         |
| 全高    | 2,815mm         | 2,830mm         |
| 軸距    | 2,750mm         | 2,750mm         |
| 輪距    | 前輪              | 1,680mm         |
|       | 後輪              | 1,660mm         |

### ●走行性能

|            |                 |                 |
|------------|-----------------|-----------------|
| 最高速度       | 49km/h          |                 |
| 登坂能力(tanθ) | 0.36            |                 |
| 最小回転半径     | GR-130F-1-00101 | GR-130F-1-00102 |
|            | 3.8m(4輪ステアリング)  | 4.1m(4輪ステアリング)  |
|            | 6.5m(2輪ステアリング)  | 6.8m(2輪ステアリング)  |

### ●重量

|       |          |
|-------|----------|
| 車両総重量 | 14,875kg |
| 前軸重   | 7,440kg  |
| 後軸重   | 7,435kg  |

### ●最大ジャッキ反力(作業時最大路面荷重)

|     |       |
|-----|-------|
| ブーム | 10.6t |
| ジブ  | 10.3t |

縮尺 1/100  
(単位: mm)

6段フルオートジブ

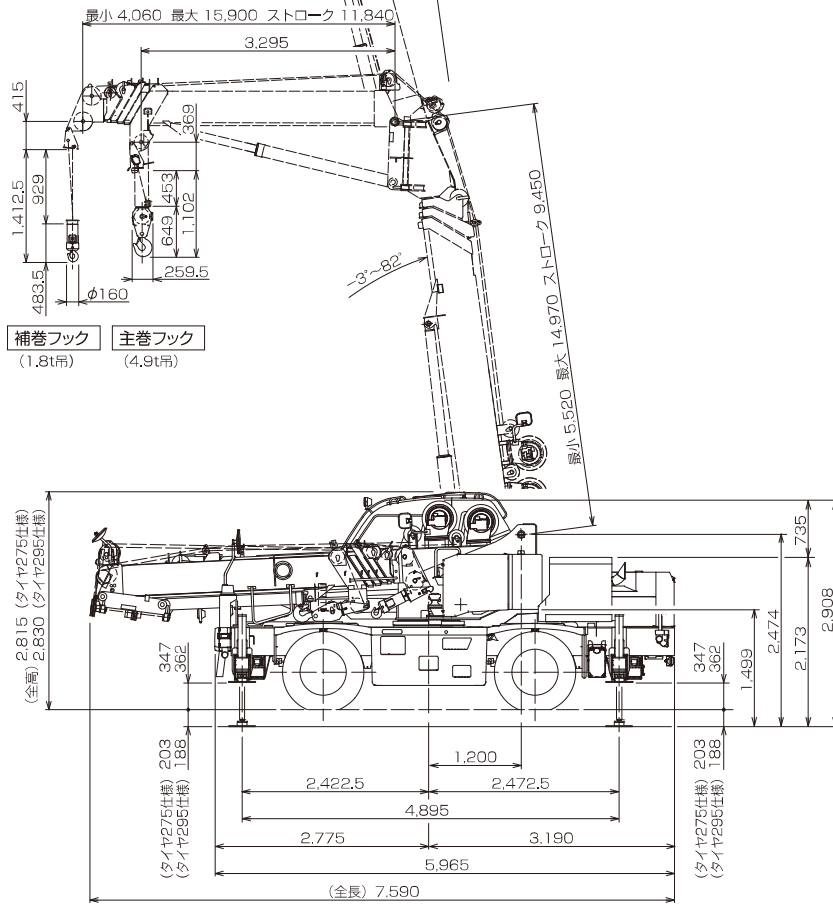

GR-130F-1-00101 : タイヤ275仕様  
GR-130F-1-00102 : タイヤ295仕様

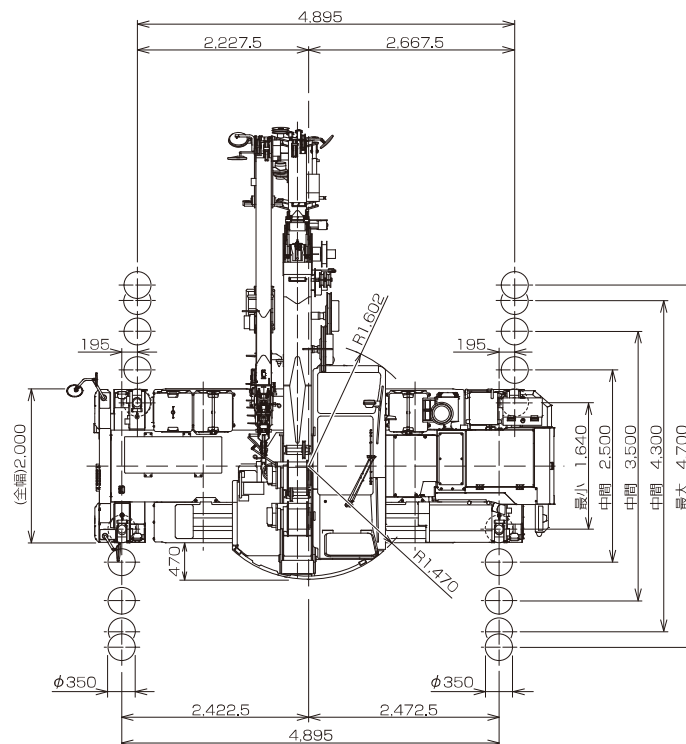

## ■外観図

縮尺 1/100  
(単位: mm)

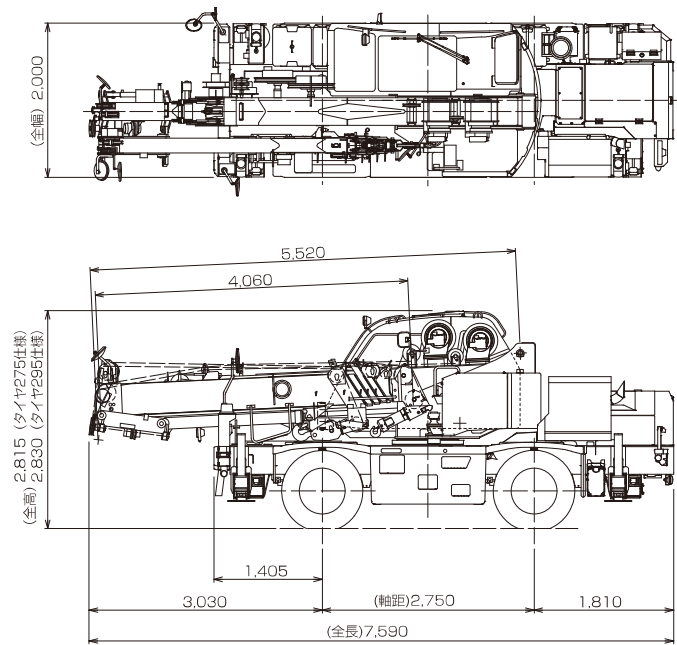

GR-130F-1-00101 : タイヤ275仕様  
GR-130F-1-00102 : タイヤ295仕様

## ■最小直角通路幅

●前2輪ステアリングで右折する場合

|              |    | GR-130F-1- |       |
|--------------|----|------------|-------|
|              |    | 00101      | 00102 |
| (最小回転半径)     | R1 | 6.50m      | 6.80m |
| (最外輪端回転半径)   | R2 | 6.64m      | 6.95m |
| (車体回転半径)     | R3 | 7.29m      | 7.85m |
| (ブーム先端回転半径)  | R4 | 8.15m      | 8.40m |
| (入口通路幅)      | A  | 3.55m      | 3.64m |
| (車輪出口通路幅)    | B  | 3.55m      | 3.64m |
| (車体出口通路幅)    | C  | 4.20m      | 4.27m |
| (ブーム先端出口通路幅) | D  | 5.06m      | 5.08m |

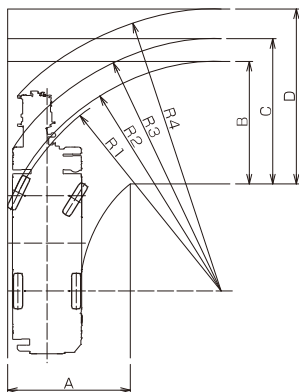

●4輪ステアリングで右折する場合

|              |    | GR-130F-1- |       |
|--------------|----|------------|-------|
|              |    | 00101      | 00102 |
| (最小回転半径)     | R1 | 3.80m      | 4.10m |
| (最外輪端回転半径)   | R2 | 3.94m      | 4.25m |
| (車体回転半径)     | R3 | 4.68m      | 4.94m |
| (ブーム先端回転半径)  | R4 | 5.54m      | 5.76m |
| (車輪入口通路幅)    | A1 | 2.43m      | 2.54m |
| (車体入口通路幅)    | A2 | 3.42m      | 3.45m |
| (車輪出口通路幅)    | B  | 2.43m      | 2.54m |
| (車体出口通路幅)    | C  | 3.46m      | 3.49m |
| (ブーム先端出口通路幅) | D  | 4.41m      | 4.39m |

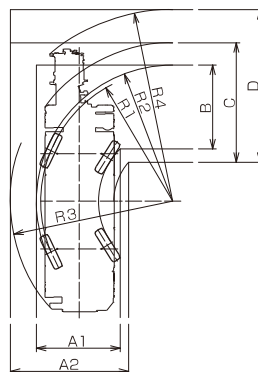

●後2輪ステアリングで右折する場合

|              |    | GR-130F-1- |       |
|--------------|----|------------|-------|
|              |    | 00101      | 00102 |
| (最小回転半径)     | R1 | 6.50m      | 6.80m |
| (最外輪端回転半径)   | R2 | 6.64m      | 6.95m |
| (車体回転半径)     | R3 | 7.37m      | 7.65m |
| (ブーム先端回転半径)  | R4 | 6.55m      | 6.86m |
| (車輪入口通路幅)    | A1 | 3.22m      | 3.33m |
| (車体入口通路幅)    | A2 | 3.96m      | 4.02m |
| (車体出口通路幅)    | C  | 3.98m      | 4.05m |
| (ブーム先端出口通路幅) | D  | 4.36m      | 4.40m |

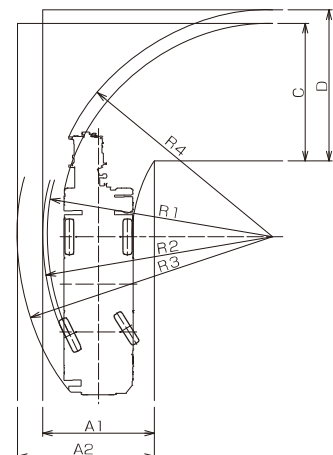

GR-130F-1-00101 : タイヤ275仕様  
GR-130F-1-00102 : タイヤ295仕様

(注) 上記数値は計算値です。

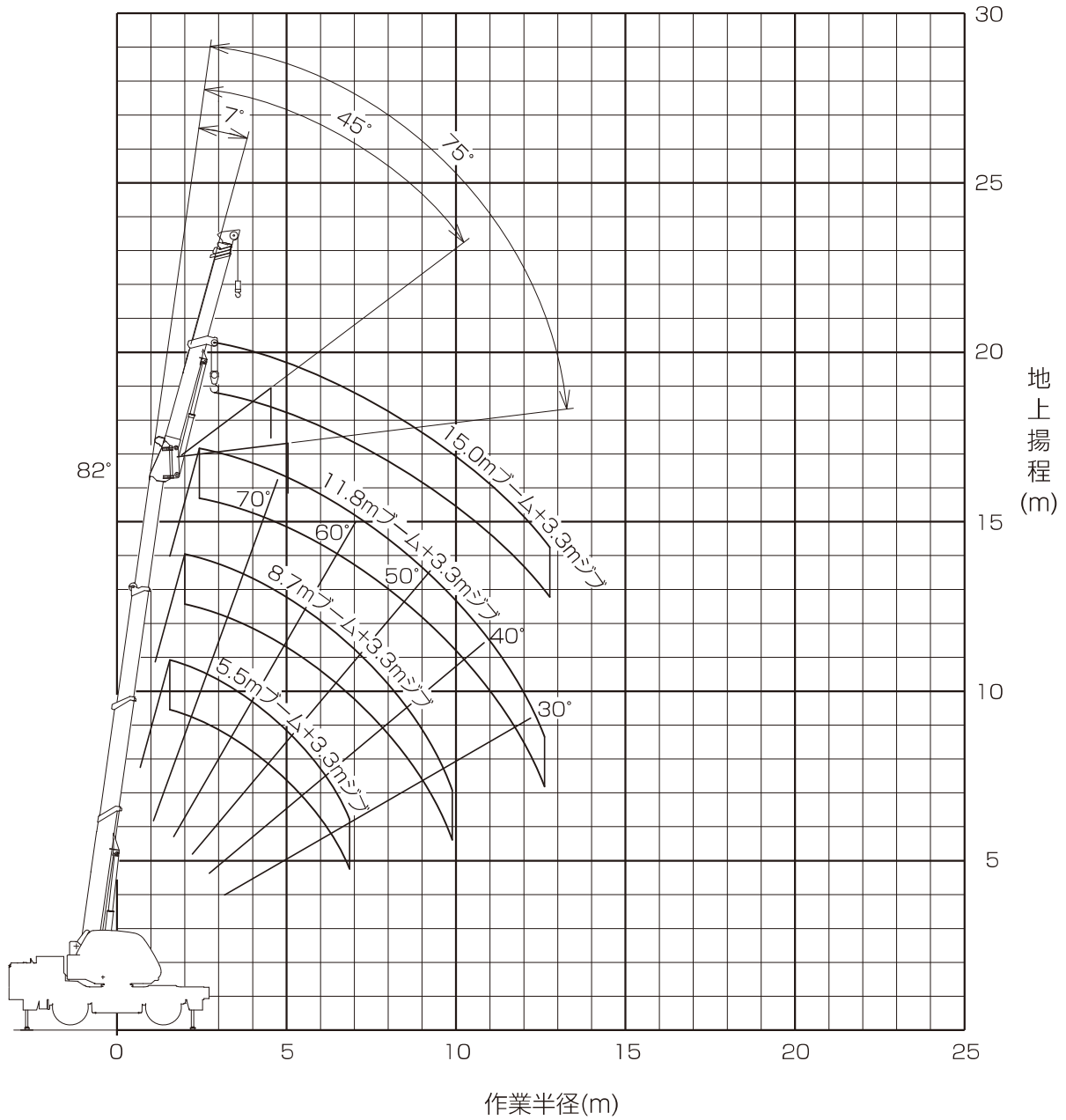

(注) 1.上図はブームのたわみを含んでいません。  
2.本図は、アウトリガ最大(4.7m)張出状態での図です。

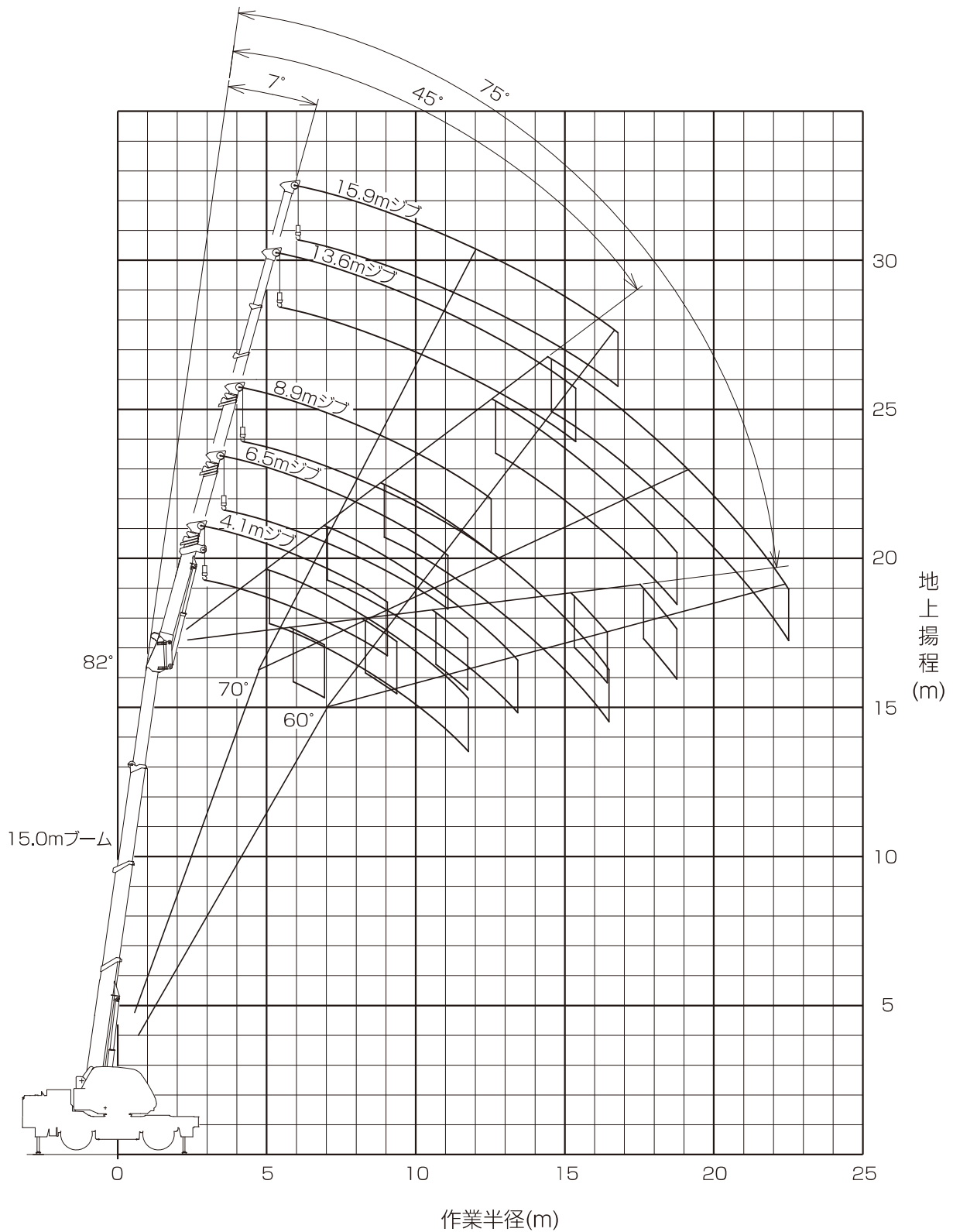

(注) 1.上図はブームのたわみを含んでいません。  
 2.本図は、アウトリガ最大(4.7m)張出状態での図です。

| 5.5mブーム+3.3mジブ |          |           |          |           |          |           |          |           |          |           |          |           |
|----------------|----------|-----------|----------|-----------|----------|-----------|----------|-----------|----------|-----------|----------|-----------|
| ジブオフセット        | 7°       |           | 15°      |           | 30°      |           | 45°      |           | 60°      |           | 75°      |           |
| ブーム角度 (°)      | 作業半径 (m) | 定格総荷重 (t) | 作業半径 (m) | 定格総荷重 (t) | 作業半径 (m) | 定格総荷重 (t) | 作業半径 (m) | 定格総荷重 (t) | 作業半径 (m) | 定格総荷重 (t) | 作業半径 (m) | 定格総荷重 (t) |
| 82             | 1.6      | 4.30      | 2.0      | 4.90      | 2.7      | 4.40      | 3.3      | 4.30      | 3.6      | 3.80      | 3.7      | 3.70      |
| 80             | 1.9      | 4.30      | 2.3      | 4.50      | 3.0      | 4.40      | 3.5      | 4.30      | 3.8      | 3.80      | 3.9      | 3.70      |
| 78             | 2.2      | 4.10      | 2.6      | 4.10      | 3.2      | 4.20      | 3.7      | 4.20      | 4.0      | 3.80      | 4.1      | 3.70      |
| 74             | 2.7      | 3.35      | 3.1      | 3.55      | 3.7      | 3.90      | 4.2      | 4.05      | 4.4      | 3.75      |          |           |
| 72             | 3.0      | 3.05      | 3.4      | 3.35      | 4.0      | 3.75      | 4.4      | 3.95      | 4.6      | 3.70      |          |           |
| 70             | 3.3      | 2.80      | 3.6      | 3.15      | 4.2      | 3.60      | 4.6      | 3.85      | 4.8      | 3.65      |          |           |
| 67             | 3.7      | 2.50      | 4.0      | 2.90      | 4.6      | 3.45      | 4.9      | 3.75      | 5.1      | 3.55      |          |           |
| 65             | 3.9      | 2.35      | 4.3      | 2.75      | 4.8      | 3.35      | 5.1      | 3.65      | 5.2      | 3.45      |          |           |
| 62             | 4.3      | 2.10      | 4.6      | 2.50      | 5.1      | 3.20      | 5.4      | 3.40      | 5.5      | 3.30      |          |           |
| 60             | 4.5      | 2.00      | 4.9      | 2.40      | 5.3      | 3.10      | 5.6      | 3.30      |          |           |          |           |
| 57             | 4.9      | 1.80      | 5.2      | 2.30      | 5.6      | 3.00      | 5.8      | 3.10      |          |           |          |           |
| 55             | 5.1      | 1.70      | 5.4      | 2.20      | 5.8      | 2.95      | 6.0      | 2.95      |          |           |          |           |
| 52             | 5.4      | 1.55      | 5.7      | 2.05      | 6.1      | 2.85      |          |           |          |           |          |           |
| 50             | 5.6      | 1.50      | 5.9      | 2.00      | 6.2      | 2.80      |          |           |          |           |          |           |
| 45             | 6.1      | 1.35      | 6.3      | 1.85      | 6.6      | 2.60      |          |           |          |           |          |           |
| 40             | 6.5      | 1.25      | 6.7      | 1.75      | 6.9      | 2.40      |          |           |          |           |          |           |
| 35             | 6.9      | 1.15      | 7.0      | 1.65      | 7.1      | 2.20      |          |           |          |           |          |           |
| A(°)           | 7~82     |           | 15~82    |           | 30~82    |           | 45~82    |           | 60~82    |           | 75~82    |           |

| 8.7mブーム+3.3mジブ |          |           |          |           |          |           |          |           |          |           |          |           |
|----------------|----------|-----------|----------|-----------|----------|-----------|----------|-----------|----------|-----------|----------|-----------|
| ジブオフセット        | 7°       |           | 15°      |           | 30°      |           | 45°      |           | 60°      |           | 75°      |           |
| ブーム角度 (°)      | 作業半径 (m) | 定格総荷重 (t) | 作業半径 (m) | 定格総荷重 (t) | 作業半径 (m) | 定格総荷重 (t) | 作業半径 (m) | 定格総荷重 (t) | 作業半径 (m) | 定格総荷重 (t) | 作業半径 (m) | 定格総荷重 (t) |
| 82             | 2.1      | 4.30      | 2.5      | 4.30      | 3.2      | 4.30      | 3.7      | 4.30      | 4.1      | 3.80      | 4.2      | 3.70      |
| 80             | 2.5      | 4.30      | 2.9      | 4.30      | 3.6      | 4.30      | 4.1      | 4.30      | 4.4      | 3.80      | 4.5      | 3.70      |
| 78             | 2.9      | 3.90      | 3.3      | 4.00      | 3.9      | 4.05      | 4.4      | 4.15      | 4.7      | 3.80      | 4.8      | 3.70      |
| 74             | 3.6      | 3.20      | 4.0      | 3.45      | 4.7      | 3.80      | 5.1      | 3.65      | 5.3      | 3.45      |          |           |
| 72             | 4.0      | 2.95      | 4.4      | 3.20      | 5.0      | 3.65      | 5.4      | 3.35      | 5.6      | 3.20      |          |           |
| 70             | 4.4      | 2.75      | 4.8      | 3.00      | 5.4      | 3.30      | 5.8      | 3.10      | 5.9      | 3.00      |          |           |
| 67             | 4.9      | 2.40      | 5.3      | 2.80      | 5.9      | 2.90      | 6.2      | 2.80      | 6.3      | 2.75      |          |           |
| 65             | 5.3      | 2.25      | 5.6      | 2.65      | 6.2      | 2.70      | 6.5      | 2.60      | 6.6      | 2.55      |          |           |
| 62             | 5.8      | 2.00      | 6.1      | 2.45      | 6.6      | 2.50      | 6.9      | 2.35      | 7.0      | 2.30      |          |           |
| 60             | 6.2      | 1.90      | 6.5      | 2.35      | 6.9      | 2.30      | 7.2      | 2.20      |          |           |          |           |
| 57             | 6.6      | 1.75      | 6.9      | 2.20      | 7.4      | 2.10      | 7.6      | 2.00      |          |           |          |           |
| 55             | 7.0      | 1.65      | 7.2      | 2.10      | 7.6      | 1.95      | 7.8      | 1.90      |          |           |          |           |
| 52             | 7.4      | 1.55      | 7.7      | 1.90      | 8.0      | 1.80      | 8.2      | 1.75      |          |           |          |           |
| 50             | 7.7      | 1.45      | 7.9      | 1.80      | 8.3      | 1.70      |          |           |          |           |          |           |
| 45             | 8.4      | 1.35      | 8.6      | 1.55      | 8.9      | 1.45      |          |           |          |           |          |           |
| 40             | 9.0      | 1.20      | 9.1      | 1.35      | 9.3      | 1.30      |          |           |          |           |          |           |
| 35             | 9.5      | 1.10      | 9.6      | 1.20      | 9.8      | 1.15      |          |           |          |           |          |           |
| 30             | 9.9      | 1.00      | 10.0     | 1.05      | 10.1     | 1.00      |          |           |          |           |          |           |
| A(°)           | 7~82     |           | 15~82    |           | 30~82    |           | 45~82    |           | 60~82    |           | 75~82    |           |

| 11.8mブーム+3.3mジブ |          |           |          |           |          |           |          |           |          |           |          |           |
|-----------------|----------|-----------|----------|-----------|----------|-----------|----------|-----------|----------|-----------|----------|-----------|
| ジブオフセット         | 7°       |           | 15°      |           | 30°      |           | 45°      |           | 60°      |           | 75°      |           |
| ブーム角度 (°)       | 作業半径 (m) | 定格総荷重 (t) | 作業半径 (m) | 定格総荷重 (t) | 作業半径 (m) | 定格総荷重 (t) | 作業半径 (m) | 定格総荷重 (t) | 作業半径 (m) | 定格総荷重 (t) | 作業半径 (m) | 定格総荷重 (t) |
| 82              | 2.6      | 4.30      | 3.0      | 4.30      | 3.7      | 4.30      | 4.3      | 4.30      | 4.6      | 3.80      | 4.7      | 3.70      |
| 80              | 3.1      | 4.30      | 3.5      | 4.15      | 4.2      | 4.20      | 4.8      | 4.00      | 5.1      | 3.80      | 5.1      | 3.60      |
| 78              | 3.6      | 3.80      | 4.0      | 3.85      | 4.7      | 3.95      | 5.2      | 3.60      | 5.5      | 3.35      | 5.5      | 3.35      |
| 74              | 4.6      | 3.10      | 5.0      | 3.35      | 5.6      | 3.10      | 6.1      | 2.90      | 6.3      | 2.75      |          |           |
| 72              | 5.1      | 2.85      | 5.5      | 3.10      | 6.1      | 2.80      | 6.5      | 2.60      | 6.7      | 2.50      |          |           |
| 70              | 5.6      | 2.60      | 5.9      | 2.85      | 6.5      | 2.50      | 6.9      | 2.40      | 7.1      | 2.30      |          |           |
| 67              | 6.3      | 2.35      | 6.6      | 2.40      | 7.2      | 2.20      | 7.6      | 2.05      | 7.7      | 2.00      |          |           |
| 65              | 6.7      | 2.20      | 7.1      | 2.20      | 7.6      | 2.00      | 7.9      | 1.85      | 8.0      | 1.85      |          |           |
| 62              | 7.4      | 1.95      | 7.7      | 1.90      | 8.2      | 1.75      | 8.5      | 1.65      |          |           |          |           |
| 60              | 7.8      | 1.80      | 8.1      | 1.75      | 8.6      | 1.65      | 8.9      | 1.55      |          |           |          |           |
| 57              | 8.4      | 1.60      | 8.7      | 1.50      | 9.2      | 1.45      | 9.4      | 1.35      |          |           |          |           |
| 55              | 8.8      | 1.45      | 9.1      | 1.40      | 9.5      | 1.30      | 9.7      | 1.25      |          |           |          |           |
| 52              | 9.4      | 1.25      | 9.7      | 1.20      | 10.1     | 1.10      | 10.2     | 1.05      |          |           |          |           |
| 50              | 9.8      | 1.15      | 10.0     | 1.10      | 10.4     | 1.00      | 10.5     | 0.95      |          |           |          |           |
| 45              | 10.7     | 0.85      | 10.9     | 0.80      | 11.2     | 0.70      | 11.2     | 0.70      |          |           |          |           |
| 40              | 11.4     | 0.60      | 11.6     | 0.55      | 11.8     | 0.50      |          |           |          |           |          |           |
| 35              | 12.1     | 0.45      | 12.3     | 0.40      |          |           |          |           |          |           |          |           |
| 30              | 12.7     | 0.30      | 12.8     | 0.25      |          |           |          |           |          |           |          |           |
| A(°)            | 25~82    |           |          |           | 30~82    |           | 45~82    |           | 60~82    |           | 75~82    |           |

| 15.0mブーム+3.3mジブ |          |           |          |           |          |           |          |           |          |           |          |           |
|-----------------|----------|-----------|----------|-----------|----------|-----------|----------|-----------|----------|-----------|----------|-----------|
| ジブオフセット         | 7°       |           | 15°      |           | 30°      |           | 45°      |           | 60°      |           | 75°      |           |
| ブーム角度 (°)       | 作業半径 (m) | 定格総荷重 (t) | 作業半径 (m) | 定格総荷重 (t) | 作業半径 (m) | 定格総荷重 (t) | 作業半径 (m) | 定格総荷重 (t) | 作業半径 (m) | 定格総荷重 (t) | 作業半径 (m) | 定格総荷重 (t) |
| 82              | 3.2      | 4.30      | 3.6      | 4.20      | 4.4      | 3.90      | 4.9      | 3.30      | 5.2      | 3.20      | 5.3      | 3.20      |
| 80              | 3.8      | 4.05      | 4.3      | 4.05      | 5.0      | 3.60      | 5.5      | 3.30      | 5.8      | 3.05      | 5.8      | 3.05      |
| 78              | 4.4      | 3.65      | 4.9      | 3.70      | 5.5      | 3.25      | 6.0      | 2.95      | 6.3      | 2.75      |          |           |
| 74              | 5.6      | 3.00      | 6.0      | 2.80      | 6.7      | 2.50      | 7.1      | 2.30      | 7.3      | 2.20      |          |           |
| 72              | 6.2      | 2.60      | 6.6      | 2.45      | 7.2      | 2.20      | 7.7      | 2.05      | 7.8      | 1.95      |          |           |
| 70              | 6.8      | 2.30      | 7.2      | 2.15      | 7.8      | 1.95      | 8.2      | 1.85      | 8.3      | 1.80      |          |           |
| 67              | 7.7      | 1.90      | 8.0      | 1.80      | 8.6      | 1.65      | 8.9      | 1.50      | 9.1      | 1.50      |          |           |
| 65              | 8.2      | 1.70      | 8.6      | 1.60      | 9.1      | 1.45      | 9.4      | 1.35      | 9.5      | 1.35      |          |           |
| 62              | 9.0      | 1.45      | 9.4      | 1.35      | 9.9      | 1.20      | 10.1     | 1.15      | 10.2     | 1.15      |          |           |
| 60              | 9.5      | 1.25      | 9.9      | 1.20      | 10.4     | 1.05      | 10.6     | 0.95      |          |           |          |           |
| 57              | 10.3     | 1.00      | 10.6     | 0.95      | 11.1     | 0.80      | 11.3     | 0.70      |          |           |          |           |
| 55              | 10.8     | 0.80      | 11.1     | 0.75      | 11.5     | 0.65      | 11.7     | 0.60      |          |           |          |           |
| 52              | 11.5     | 0.60      | 11.8     | 0.55      | 12.2     | 0.45      | 12.3     | 0.40      |          |           |          |           |
| 50              | 12.0     | 0.45      | 12.2     | 0.40      | 12.6     | 0.30      | 12.7     | 0.30      |          |           |          |           |
| 45              | 13.0     | 0.20      |          |           |          |           |          |           |          |           |          |           |
| A(°)            | 40~82    |           |          |           | 45~82    |           |          |           | 60~82    |           | 75~82    |           |

| 5.5mブーム+3.3mジブ |          |           |          |           |          |           |          |           |          |           |          |           |
|----------------|----------|-----------|----------|-----------|----------|-----------|----------|-----------|----------|-----------|----------|-----------|
| ジブオフセット        | 7°       |           | 15°      |           | 30°      |           | 45°      |           | 60°      |           | 75°      |           |
| ブーム角度 (°)      | 作業半径 (m) | 定格総荷重 (t) | 作業半径 (m) | 定格総荷重 (t) | 作業半径 (m) | 定格総荷重 (t) | 作業半径 (m) | 定格総荷重 (t) | 作業半径 (m) | 定格総荷重 (t) | 作業半径 (m) | 定格総荷重 (t) |
| 82             | 1.6      | 4.30      | 2.0      | 4.90      | 2.7      | 4.40      | 3.3      | 4.30      | 3.6      | 3.80      | 3.7      | 3.70      |
| 80             | 1.9      | 4.30      | 2.3      | 4.50      | 3.0      | 4.40      | 3.5      | 4.30      | 3.8      | 3.80      | 3.9      | 3.70      |
| 78             | 2.2      | 4.10      | 2.6      | 4.10      | 3.2      | 4.20      | 3.7      | 4.20      | 4.0      | 3.80      | 4.1      | 3.70      |
| 74             | 2.7      | 3.35      | 3.1      | 3.55      | 3.7      | 3.90      | 4.2      | 4.05      | 4.4      | 3.70      |          |           |
| 72             | 3.0      | 3.05      | 3.4      | 3.35      | 4.0      | 3.75      | 4.4      | 3.95      | 4.6      | 3.70      |          |           |
| 70             | 3.3      | 2.80      | 3.6      | 3.15      | 4.2      | 3.60      | 4.6      | 3.85      | 4.8      | 3.65      |          |           |
| 67             | 3.7      | 2.50      | 4.0      | 2.90      | 4.6      | 3.45      | 4.9      | 3.75      | 5.1      | 3.55      |          |           |
| 65             | 3.9      | 2.35      | 4.3      | 2.75      | 4.8      | 3.35      | 5.1      | 3.65      | 5.2      | 3.45      |          |           |
| 62             | 4.3      | 2.10      | 4.6      | 2.50      | 5.1      | 3.20      | 5.4      | 3.40      | 5.5      | 3.30      |          |           |
| 60             | 4.5      | 2.00      | 4.9      | 2.40      | 5.3      | 3.10      | 5.6      | 3.30      |          |           |          |           |
| 57             | 4.9      | 1.80      | 5.2      | 2.30      | 5.6      | 3.00      | 5.8      | 3.10      |          |           |          |           |
| 55             | 5.1      | 1.70      | 5.4      | 2.20      | 5.8      | 2.95      | 6.0      | 2.95      |          |           |          |           |
| 52             | 5.4      | 1.55      | 5.7      | 2.05      | 6.1      | 2.85      |          |           |          |           |          |           |
| 50             | 5.6      | 1.50      | 5.9      | 2.00      | 6.2      | 2.80      |          |           |          |           |          |           |
| 45             | 6.1      | 1.35      | 6.3      | 1.85      | 6.6      | 2.60      |          |           |          |           |          |           |
| 40             | 6.5      | 1.25      | 6.7      | 1.75      | 6.9      | 2.40      |          |           |          |           |          |           |
| 35             | 6.9      | 1.15      | 7.0      | 1.65      | 7.1      | 2.20      |          |           |          |           |          |           |
| A(°)           | 7~82     |           | 15~82    |           | 30~82    |           | 45~82    |           | 60~82    |           | 75~82    |           |

| 8.7mブーム+3.3mジブ |          |           |          |           |          |           |          |           |          |           |          |           |
|----------------|----------|-----------|----------|-----------|----------|-----------|----------|-----------|----------|-----------|----------|-----------|
| ジブオフセット        | 7°       |           | 15°      |           | 30°      |           | 45°      |           | 60°      |           | 75°      |           |
| ブーム角度 (°)      | 作業半径 (m) | 定格総荷重 (t) | 作業半径 (m) | 定格総荷重 (t) | 作業半径 (m) | 定格総荷重 (t) | 作業半径 (m) | 定格総荷重 (t) | 作業半径 (m) | 定格総荷重 (t) | 作業半径 (m) | 定格総荷重 (t) |
| 82             | 2.1      | 4.30      | 2.5      | 4.30      | 3.2      | 4.30      | 3.7      | 4.30      | 4.1      | 3.80      | 4.2      | 3.70      |
| 80             | 2.5      | 4.30      | 2.9      | 4.30      | 3.6      | 4.30      | 4.1      | 4.30      | 4.4      | 3.80      | 4.5      | 3.70      |
| 78             | 2.9      | 3.90      | 3.3      | 4.00      | 3.9      | 4.05      | 4.4      | 4.15      | 4.7      | 3.80      | 4.8      | 3.70      |
| 74             | 3.6      | 3.20      | 4.0      | 3.45      | 4.7      | 3.80      | 5.1      | 3.65      | 5.3      | 3.45      |          |           |
| 72             | 4.0      | 2.95      | 4.4      | 3.20      | 5.0      | 3.65      | 5.4      | 3.35      | 5.6      | 3.20      |          |           |
| 70             | 4.4      | 2.75      | 4.8      | 3.00      | 5.4      | 3.30      | 5.8      | 3.10      | 5.9      | 3.00      |          |           |
| 67             | 4.9      | 2.40      | 5.3      | 2.80      | 5.9      | 2.90      | 6.2      | 2.80      | 6.3      | 2.75      |          |           |
| 65             | 5.3      | 2.25      | 5.6      | 2.65      | 6.2      | 2.70      | 6.5      | 2.60      | 6.6      | 2.55      |          |           |
| 62             | 5.8      | 2.00      | 6.1      | 2.45      | 6.6      | 2.50      | 6.9      | 2.35      | 7.0      | 2.30      |          |           |
| 60             | 6.2      | 1.90      | 6.5      | 2.35      | 6.9      | 2.30      | 7.2      | 2.20      |          |           |          |           |
| 57             | 6.6      | 1.75      | 6.9      | 2.20      | 7.4      | 2.10      | 7.6      | 2.00      |          |           |          |           |
| 55             | 7.0      | 1.65      | 7.2      | 2.10      | 7.6      | 1.95      | 7.8      | 1.90      |          |           |          |           |
| 52             | 7.4      | 1.55      | 7.7      | 1.90      | 8.0      | 1.80      | 8.2      | 1.75      |          |           |          |           |
| 50             | 7.7      | 1.45      | 7.9      | 1.80      | 8.3      | 1.70      |          |           |          |           |          |           |
| 45             | 8.4      | 1.35      | 8.6      | 1.55      | 8.9      | 1.45      |          |           |          |           |          |           |
| 40             | 9.0      | 1.20      | 9.1      | 1.35      | 9.3      | 1.25      |          |           |          |           |          |           |
| 35             | 9.5      | 1.10      | 9.6      | 1.20      | 9.8      | 1.05      |          |           |          |           |          |           |
| 30             | 9.9      | 1.00      | 10.0     | 0.95      | 10.1     | 0.90      |          |           |          |           |          |           |
| A(°)           | 7~82     |           | 15~82    |           | 30~82    |           | 45~82    |           | 60~82    |           | 75~82    |           |

| 11.8mブーム+3.3mジブ |          |           |          |           |          |           |          |           |          |           |          |           |
|-----------------|----------|-----------|----------|-----------|----------|-----------|----------|-----------|----------|-----------|----------|-----------|
| ジブオフセット         | 7°       |           | 15°      |           | 30°      |           | 45°      |           | 60°      |           | 75°      |           |
| ブーム角度 (°)       | 作業半径 (m) | 定格総荷重 (t) | 作業半径 (m) | 定格総荷重 (t) | 作業半径 (m) | 定格総荷重 (t) | 作業半径 (m) | 定格総荷重 (t) | 作業半径 (m) | 定格総荷重 (t) | 作業半径 (m) | 定格総荷重 (t) |
| 82              | 2.6      | 4.30      | 3.0      | 4.30      | 3.7      | 4.30      | 4.3      | 4.30      | 4.6      | 3.80      | 4.7      | 3.70      |
| 80              | 3.1      | 4.30      | 3.5      | 4.15      | 4.2      | 4.20      | 4.8      | 4.00      | 5.1      | 3.80      | 5.1      | 3.60      |
| 78              | 3.6      | 3.80      | 4.0      | 3.85      | 4.7      | 3.95      | 5.2      | 3.60      | 5.5      | 3.35      | 5.5      | 3.35      |
| 74              | 4.6      | 3.10      | 5.0      | 3.35      | 5.6      | 3.10      | 6.1      | 2.90      | 6.3      | 2.75      |          |           |
| 72              | 5.1      | 2.85      | 5.5      | 3.10      | 6.1      | 2.80      | 6.5      | 2.60      | 6.7      | 2.50      |          |           |
| 70              | 5.6      | 2.60      | 5.9      | 2.85      | 6.5      | 2.50      | 6.9      | 2.40      | 7.1      | 2.30      |          |           |
| 67              | 6.3      | 2.35      | 6.6      | 2.40      | 7.2      | 2.20      | 7.6      | 2.05      | 7.7      | 2.00      |          |           |
| 65              | 6.7      | 2.20      | 7.1      | 2.20      | 7.6      | 2.00      | 7.9      | 1.85      | 8.0      | 1.85      |          |           |
| 62              | 7.4      | 1.95      | 7.7      | 1.90      | 8.2      | 1.75      | 8.5      | 1.65      |          |           |          |           |
| 60              | 7.8      | 1.80      | 8.1      | 1.75      | 8.6      | 1.65      | 8.9      | 1.55      |          |           |          |           |
| 57              | 8.4      | 1.60      | 8.7      | 1.50      | 9.2      | 1.45      | 9.4      | 1.30      |          |           |          |           |
| 55              | 8.8      | 1.45      | 9.1      | 1.40      | 9.5      | 1.25      | 9.7      | 1.15      |          |           |          |           |
| 52              | 9.4      | 1.25      | 9.7      | 1.15      | 10.1     | 1.00      | 10.2     | 0.95      |          |           |          |           |
| 50              | 9.8      | 1.10      | 10.0     | 1.05      | 10.4     | 0.90      | 10.5     | 0.85      |          |           |          |           |
| 45              | 10.7     | 0.75      | 10.9     | 0.70      | 11.2     | 0.60      | 11.2     | 0.60      |          |           |          |           |
| 40              | 11.4     | 0.50      | 11.6     | 0.45      | 11.8     | 0.40      |          |           |          |           |          |           |
| A(°)            | 30~82    |           | 35~82    |           | 45~82    |           | 60~82    |           | 75~82    |           |          |           |

| 15.0mブーム+3.3mジブ |          |           |          |           |          |           |          |           |          |           |          |           |
|-----------------|----------|-----------|----------|-----------|----------|-----------|----------|-----------|----------|-----------|----------|-----------|
| ジブオフセット         | 7°       |           | 15°      |           | 30°      |           | 45°      |           | 60°      |           | 75°      |           |
| ブーム角度 (°)       | 作業半径 (m) | 定格総荷重 (t) | 作業半径 (m) | 定格総荷重 (t) | 作業半径 (m) | 定格総荷重 (t) | 作業半径 (m) | 定格総荷重 (t) | 作業半径 (m) | 定格総荷重 (t) | 作業半径 (m) | 定格総荷重 (t) |
| 82              | 3.2      | 4.30      | 3.6      | 4.20      | 4.4      | 3.90      | 4.9      | 3.30      | 5.2      | 3.20      | 5.3      | 3.20      |
| 80              | 3.8      | 4.05      | 4.3      | 4.05      | 5.0      | 3.60      | 5.5      | 3.30      | 5.8      | 3.05      | 5.8      | 3.05      |
| 78              | 4.4      | 3.65      | 4.9      | 3.70      | 5.5      | 3.25      | 6.0      | 2.95      | 6.3      | 2.75      |          |           |
| 74              | 5.6      | 3.00      | 6.0      | 2.80      | 6.7      | 2.50      | 7.1      | 2.30      | 7.3      | 2.20      |          |           |
| 72              | 6.2      | 2.60      | 6.6      | 2.45      | 7.2      | 2.20      | 7.7      | 2.05      | 7.8      | 1.95      |          |           |
| 70              | 6.8      | 2.30      | 7.2      | 2.15      | 7.8      | 1.95      | 8.2      | 1.85      | 8.3      | 1.80      |          |           |
| 67              | 7.7      | 1.90      | 8.0      | 1.80      | 8.6      | 1.65      | 8.9      | 1.50      | 9.1      | 1.50      |          |           |
| 65              | 8.2      | 1.70      | 8.6      | 1.60      | 9.1      | 1.45      | 9.4      | 1.35      | 9.5      | 1.30      |          |           |
| 62              | 9.0      | 1.45      | 9.4      | 1.30      | 9.9      | 1.15      | 10.1     | 1.05      | 10.2     | 1.05      |          |           |
| 60              | 9.5      | 1.25      | 9.9      | 1.10      | 10.4     | 0.95      | 10.6     | 0.85      |          |           |          |           |
| 57              | 10.3     | 0.95      | 10.6     | 0.85      | 11.1     | 0.65      | 11.3     | 0.60      |          |           |          |           |
| 55              | 10.8     | 0.70      | 11.1     | 0.65      | 11.5     | 0.55      | 11.7     | 0.50      |          |           |          |           |
| 52              | 11.5     | 0.50      | 11.8     | 0.45      |          |           |          |           |          |           |          |           |
| 50              | 12.0     | 0.35      |          |           |          |           |          |           |          |           |          |           |
| A(°)            | 45~82    |           | 50~82    |           | 52~82    |           | 60~82    |           | 75~82    |           |          |           |

A: ブーム角度の範囲 (無負荷時)

| 5.5mブーム+3.3mジブ |          |           |          |           |          |           |          |           |          |           |          |           |
|----------------|----------|-----------|----------|-----------|----------|-----------|----------|-----------|----------|-----------|----------|-----------|
| ジブオフセット        | 7°       |           | 15°      |           | 30°      |           | 45°      |           | 60°      |           | 75°      |           |
| ブーム角度 (°)      | 作業半径 (m) | 定格総荷重 (t) | 作業半径 (m) | 定格総荷重 (t) | 作業半径 (m) | 定格総荷重 (t) | 作業半径 (m) | 定格総荷重 (t) | 作業半径 (m) | 定格総荷重 (t) | 作業半径 (m) | 定格総荷重 (t) |
| 82             | 1.6      | 4.30      | 2.0      | 4.90      | 2.7      | 4.40      | 3.3      | 4.30      | 3.6      | 3.80      | 3.7      | 3.70      |
| 80             | 1.9      | 4.30      | 2.3      | 4.50      | 3.0      | 4.40      | 3.5      | 4.30      | 3.8      | 3.80      | 3.9      | 3.70      |
| 78             | 2.2      | 4.10      | 2.6      | 4.10      | 3.2      | 4.20      | 3.7      | 4.20      | 4.0      | 3.80      | 4.1      | 3.70      |
| 74             | 2.7      | 3.35      | 3.1      | 3.55      | 3.7      | 3.90      | 4.2      | 4.05      | 4.4      | 3.75      |          |           |
| 72             | 3.0      | 3.05      | 3.4      | 3.35      | 4.0      | 3.75      | 4.4      | 3.95      | 4.6      | 3.70      |          |           |
| 70             | 3.3      | 2.80      | 3.6      | 3.15      | 4.2      | 3.60      | 4.6      | 3.85      | 4.8      | 3.65      |          |           |
| 67             | 3.7      | 2.50      | 4.0      | 2.90      | 4.6      | 3.45      | 4.9      | 3.75      | 5.1      | 3.55      |          |           |
| 65             | 3.9      | 2.35      | 4.3      | 2.75      | 4.8      | 3.35      | 5.1      | 3.65      | 5.2      | 3.45      |          |           |
| 62             | 4.3      | 2.10      | 4.6      | 2.50      | 5.1      | 3.20      | 5.4      | 3.40      | 5.5      | 3.30      |          |           |
| 60             | 4.5      | 2.00      | 4.9      | 2.40      | 5.3      | 3.10      | 5.6      | 3.20      |          |           |          |           |
| 57             | 4.9      | 1.80      | 5.2      | 2.30      | 5.6      | 2.95      | 5.8      | 2.90      |          |           |          |           |
| 55             | 5.1      | 1.70      | 5.4      | 2.20      | 5.8      | 2.85      | 6.0      | 2.70      |          |           |          |           |
| 52             | 5.4      | 1.55      | 5.7      | 2.05      | 6.1      | 2.65      |          |           |          |           |          |           |
| 50             | 5.6      | 1.50      | 5.9      | 2.00      | 6.2      | 2.55      |          |           |          |           |          |           |
| 45             | 6.1      | 1.35      | 6.3      | 1.85      | 6.6      | 2.20      |          |           |          |           |          |           |
| 40             | 6.5      | 1.25      | 6.7      | 1.75      | 6.9      | 1.90      |          |           |          |           |          |           |
| 35             | 6.9      | 1.15      | 7.0      | 1.65      | 7.1      | 1.70      |          |           |          |           |          |           |
| A(°)           | 7~82     |           | 15~82    |           | 30~82    |           | 45~82    |           | 60~82    |           | 75~82    |           |

| 8.7mブーム+3.3mジブ |          |           |          |           |          |           |          |           |          |           |          |           |
|----------------|----------|-----------|----------|-----------|----------|-----------|----------|-----------|----------|-----------|----------|-----------|
| ジブオフセット        | 7°       |           | 15°      |           | 30°      |           | 45°      |           | 60°      |           | 75°      |           |
| ブーム角度 (°)      | 作業半径 (m) | 定格総荷重 (t) | 作業半径 (m) | 定格総荷重 (t) | 作業半径 (m) | 定格総荷重 (t) | 作業半径 (m) | 定格総荷重 (t) | 作業半径 (m) | 定格総荷重 (t) | 作業半径 (m) | 定格総荷重 (t) |
| 82             | 2.1      | 4.30      | 2.5      | 4.30      | 3.2      | 4.30      | 3.7      | 4.30      | 4.1      | 3.80      | 4.2      | 3.70      |
| 80             | 2.5      | 4.30      | 2.9      | 4.30      | 3.6      | 4.30      | 4.1      | 4.30      | 4.4      | 3.80      | 4.5      | 3.70      |
| 78             | 2.9      | 3.90      | 3.3      | 4.00      | 3.9      | 4.05      | 4.4      | 4.15      | 4.7      | 3.80      | 4.8      | 3.70      |
| 74             | 3.6      | 3.20      | 4.0      | 3.45      | 4.7      | 3.80      | 5.1      | 3.65      | 5.3      | 3.40      |          |           |
| 72             | 4.0      | 2.95      | 4.4      | 3.20      | 5.0      | 3.65      | 5.4      | 3.30      | 5.6      | 3.10      |          |           |
| 70             | 4.4      | 2.75      | 4.8      | 3.00      | 5.4      | 3.30      | 5.8      | 2.90      | 5.9      | 2.75      |          |           |
| 67             | 4.9      | 2.40      | 5.3      | 2.80      | 5.9      | 2.70      | 6.2      | 2.40      | 6.3      | 2.35      |          |           |
| 65             | 5.3      | 2.25      | 5.6      | 2.65      | 6.2      | 2.40      | 6.5      | 2.20      | 6.6      | 2.10      |          |           |
| 62             | 5.8      | 2.00      | 6.1      | 2.40      | 6.6      | 2.00      | 6.9      | 1.80      | 7.0      | 1.75      |          |           |
| 60             | 6.2      | 1.90      | 6.5      | 2.10      | 6.9      | 1.75      | 7.2      | 1.60      |          |           |          |           |
| 57             | 6.6      | 1.75      | 6.9      | 1.70      | 7.4      | 1.50      | 7.6      | 1.35      |          |           |          |           |
| 55             | 7.0      | 1.65      | 7.2      | 1.50      | 7.6      | 1.30      | 7.8      | 1.20      |          |           |          |           |
| 52             | 7.4      | 1.45      | 7.7      | 1.30      | 8.0      | 1.10      | 8.2      | 1.00      |          |           |          |           |
| 50             | 7.7      | 1.30      | 7.9      | 1.10      | 8.3      | 1.00      |          |           |          |           |          |           |
| 45             | 8.4      | 0.95      | 8.6      | 0.85      | 8.9      | 0.70      |          |           |          |           |          |           |
| 40             | 9.0      | 0.65      | 9.1      | 0.60      | 9.3      | 0.52      |          |           |          |           |          |           |
| 35             | 9.5      | 0.45      | 9.6      | 0.40      | 9.8      | 0.36      |          |           |          |           |          |           |
| 30             | 9.9      | 0.25      | 10.0     | 0.25      | 10.1     | 0.22      |          |           |          |           |          |           |
| A(°)           | 25~82    |           | 30~82    |           | 45~82    |           | 60~82    |           | 75~82    |           |          |           |

| 11.8mブーム+3.3mジブ |          |           |          |           |          |           |          |           |          |           |          |           |
|-----------------|----------|-----------|----------|-----------|----------|-----------|----------|-----------|----------|-----------|----------|-----------|
| ジブオフセット         | 7°       |           | 15°      |           | 30°      |           | 45°      |           | 60°      |           | 75°      |           |
| ブーム角度 (°)       | 作業半径 (m) | 定格総荷重 (t) | 作業半径 (m) | 定格総荷重 (t) | 作業半径 (m) | 定格総荷重 (t) | 作業半径 (m) | 定格総荷重 (t) | 作業半径 (m) | 定格総荷重 (t) | 作業半径 (m) | 定格総荷重 (t) |
| 82              | 2.6      | 4.30      | 3.0      | 4.30      | 3.7      | 4.30      | 4.3      | 4.30      | 4.6      | 3.80      | 4.7      | 3.70      |
| 80              | 3.1      | 4.30      | 3.5      | 4.15      | 4.2      | 4.20      | 4.8      | 4.00      | 5.1      | 3.80      | 5.1      | 3.60      |
| 78              | 3.6      | 3.80      | 4.0      | 3.85      | 4.7      | 3.95      | 5.2      | 3.60      | 5.5      | 3.30      | 5.5      | 3.25      |
| 74              | 4.6      | 3.10      | 5.0      | 3.35      | 5.6      | 3.05      | 6.1      | 2.60      | 6.3      | 2.40      |          |           |
| 72              | 5.1      | 2.85      | 5.5      | 3.10      | 6.1      | 2.55      | 6.5      | 2.25      | 6.7      | 2.10      |          |           |
| 70              | 5.6      | 2.60      | 5.9      | 2.65      | 6.5      | 2.15      | 6.9      | 1.90      | 7.1      | 1.80      |          |           |
| 67              | 6.3      | 2.20      | 6.6      | 2.05      | 7.2      | 1.70      | 7.6      | 1.50      | 7.7      | 1.45      |          |           |
| 65              | 6.7      | 1.90      | 7.1      | 1.65      | 7.6      | 1.45      | 7.9      | 1.30      | 8.0      | 1.25      |          |           |
| 62              | 7.4      | 1.45      | 7.7      | 1.30      | 8.2      | 1.10      | 8.5      | 1.00      |          |           |          |           |
| 60              | 7.8      | 1.20      | 8.1      | 1.10      | 8.6      | 0.90      | 8.9      | 0.85      |          |           |          |           |
| 57              | 8.4      | 0.90      | 8.7      | 0.80      | 9.2      | 0.70      | 9.4      | 0.65      |          |           |          |           |
| 55              | 8.8      | 0.75      | 9.1      | 0.65      | 9.5      | 0.55      | 9.7      | 0.50      |          |           |          |           |
| 52              | 9.4      | 0.55      | 9.7      | 0.45      | 10.1     | 0.35      |          |           |          |           |          |           |
| 50              | 9.8      | 0.40      | 10.0     | 0.35      |          |           |          |           |          |           |          |           |
| A(°)            | 45~82    |           | 50~82    |           | 52~82    |           | 60~82    |           | 75~82    |           |          |           |

| 15.0mブーム+3.3mジブ |          |           |          |           |          |           |          |           |          |           |          |           |
|-----------------|----------|-----------|----------|-----------|----------|-----------|----------|-----------|----------|-----------|----------|-----------|
| ジブオフセット         | 7°       |           | 15°      |           | 30°      |           | 45°      |           | 60°      |           | 75°      |           |
| ブーム角度 (°)       | 作業半径 (m) | 定格総荷重 (t) | 作業半径 (m) | 定格総荷重 (t) | 作業半径 (m) | 定格総荷重 (t) | 作業半径 (m) | 定格総荷重 (t) | 作業半径 (m) | 定格総荷重 (t) | 作業半径 (m) | 定格総荷重 (t) |
| 82              | 3.2      | 4.30      | 3.6      | 4.20      | 4.4      | 3.90      | 4.9      | 3.30      | 5.2      | 3.20      | 5.3      | 3.20      |
| 80              | 3.8      | 4.05      | 4.3      | 4.05      | 5.0      | 3.60      | 5.5      | 3.30      | 5.8      | 2.95      | 5.8      | 2.85      |
| 78              | 4.4      | 3.65      | 4.9      | 3.70      | 5.5      | 3.25      | 6.0      | 2.70      | 6.3      | 2.45      |          |           |
| 74              | 5.6      | 2.95      | 6.0      | 2.55      | 6.7      | 2.05      | 7.1      | 1.75      | 7.3      | 1.65      |          |           |
| 72              | 6.2      | 2.30      | 6.6      | 2.00      | 7.2      | 1.65      | 7.7      | 1.45      | 7.8      | 1.35      |          |           |
| 70              | 6.8      | 1.85      | 7.2      | 1.60      | 7.8      | 1.35      | 8.2      | 1.15      | 8.3      | 1.10      |          |           |
| 67              | 7.7      | 1.35      | 8.0      | 1.15      | 8.6      | 1.00      | 8.9      | 0.85      | 9.1      | 0.80      |          |           |
| 65              | 8.2      | 1.05      | 8.6      | 0.90      | 9.1      | 0.75      | 9.4      | 0.65      | 9.5      | 0.60      |          |           |
| 62              | 9.0      | 0.70      | 9.4      | 0.60      | 9.9      | 0.50      |          |           |          |           |          |           |
| 60              | 9.5      | 0.50      | 9.9      | 0.45      |          |           |          |           |          |           |          |           |
| A(°)            | 57~82    |           | 60~82    |           | 62~82    |           | 75~82    |           |          |           |          |           |

A: ブーム角度の範囲 (無負荷時)

■ 定格総荷重表 [主巻作業] アウトリガ中間張出 (2.5m) ー側方ー

主巻作業

| 5.5mブーム+3.3mジブ |          |           |          |           |          |           |          |           |          |           |          |           |
|----------------|----------|-----------|----------|-----------|----------|-----------|----------|-----------|----------|-----------|----------|-----------|
| ジブオフセット        | 7°       |           | 15°      |           | 30°      |           | 45°      |           | 60°      |           | 75°      |           |
| ブーム角度 (°)      | 作業半径 (m) | 定格総荷重 (t) | 作業半径 (m) | 定格総荷重 (t) | 作業半径 (m) | 定格総荷重 (t) | 作業半径 (m) | 定格総荷重 (t) | 作業半径 (m) | 定格総荷重 (t) | 作業半径 (m) | 定格総荷重 (t) |
| 82             | 1.6      | 4.30      | 2.0      | 4.90      | 2.7      | 4.40      | 3.3      | 4.30      | 3.6      | 3.50      | 3.7      | 3.50      |
| 80             | 1.9      | 4.30      | 2.3      | 4.50      | 3.0      | 4.40      | 3.5      | 4.30      | 3.8      | 3.50      | 3.9      | 3.50      |
| 78             | 2.2      | 4.10      | 2.6      | 4.10      | 3.2      | 4.20      | 3.7      | 3.90      | 4.0      | 3.50      | 4.1      | 3.30      |
| 74             | 2.7      | 3.35      | 3.1      | 3.55      | 3.7      | 3.75      | 4.2      | 3.10      | 4.4      | 2.75      |          |           |
| 72             | 3.0      | 3.05      | 3.4      | 3.35      | 4.0      | 3.40      | 4.4      | 2.75      | 4.6      | 2.50      |          |           |
| 70             | 3.3      | 2.80      | 3.6      | 3.15      | 4.2      | 3.05      | 4.6      | 2.45      | 4.8      | 2.30      |          |           |
| 67             | 3.7      | 2.50      | 4.0      | 2.90      | 4.6      | 2.50      | 4.9      | 2.10      | 5.1      | 2.00      |          |           |
| 65             | 3.9      | 2.35      | 4.3      | 2.70      | 4.8      | 2.25      | 5.1      | 1.95      | 5.2      | 1.80      |          |           |
| 62             | 4.3      | 2.10      | 4.6      | 2.40      | 5.1      | 1.95      | 5.4      | 1.70      | 5.5      | 1.55      |          |           |
| 60             | 4.5      | 2.00      | 4.9      | 2.10      | 5.3      | 1.75      | 5.6      | 1.55      |          |           |          |           |
| 57             | 4.9      | 1.80      | 5.2      | 1.80      | 5.6      | 1.50      | 5.8      | 1.30      |          |           |          |           |
| 55             | 5.1      | 1.70      | 5.4      | 1.60      | 5.8      | 1.35      | 6.0      | 1.20      |          |           |          |           |
| 52             | 5.4      | 1.55      | 5.7      | 1.35      | 6.1      | 1.20      |          |           |          |           |          |           |
| 50             | 5.6      | 1.40      | 5.9      | 1.20      | 6.2      | 1.10      |          |           |          |           |          |           |
| 45             | 6.1      | 1.10      | 6.3      | 1.00      | 6.6      | 0.90      |          |           |          |           |          |           |
| 40             | 6.5      | 0.90      | 6.7      | 0.80      | 6.9      | 0.70      |          |           |          |           |          |           |
| 35             | 6.9      | 0.70      | 7.0      | 0.65      |          |           |          |           |          |           |          |           |
| A(°)           | 30~82    |           |          |           | 35~82    |           | 45~82    |           | 60~82    |           | 75~82    |           |

| 8.7mブーム+3.3mジブ |          |           |          |           |          |           |          |           |          |           |          |           |
|----------------|----------|-----------|----------|-----------|----------|-----------|----------|-----------|----------|-----------|----------|-----------|
| ジブオフセット        | 7°       |           | 15°      |           | 30°      |           | 45°      |           | 60°      |           | 75°      |           |
| ブーム角度 (°)      | 作業半径 (m) | 定格総荷重 (t) | 作業半径 (m) | 定格総荷重 (t) | 作業半径 (m) | 定格総荷重 (t) | 作業半径 (m) | 定格総荷重 (t) | 作業半径 (m) | 定格総荷重 (t) | 作業半径 (m) | 定格総荷重 (t) |
| 82             | 2.1      | 4.30      | 2.5      | 4.30      | 3.2      | 4.30      | 3.7      | 3.40      | 4.1      | 2.60      | 4.2      | 2.60      |
| 80             | 2.5      | 4.30      | 2.9      | 4.30      | 3.6      | 4.30      | 4.1      | 3.40      | 4.4      | 2.60      | 4.5      | 2.60      |
| 78             | 2.9      | 3.90      | 3.3      | 4.00      | 3.9      | 3.35      | 4.4      | 2.65      | 4.7      | 2.35      | 4.8      | 2.25      |
| 74             | 3.6      | 3.20      | 4.0      | 3.10      | 4.7      | 2.30      | 5.1      | 1.90      | 5.3      | 1.65      |          |           |
| 72             | 4.0      | 2.95      | 4.4      | 2.50      | 5.0      | 1.90      | 5.4      | 1.55      | 5.6      | 1.40      |          |           |
| 70             | 4.4      | 2.45      | 4.8      | 2.05      | 5.4      | 1.60      | 5.8      | 1.30      | 5.9      | 1.20      |          |           |
| 67             | 4.9      | 1.80      | 5.3      | 1.55      | 5.9      | 1.20      | 6.2      | 1.05      | 6.3      | 0.95      |          |           |
| 65             | 5.3      | 1.50      | 5.6      | 1.30      | 6.2      | 1.00      | 6.5      | 0.85      | 6.6      | 0.80      |          |           |
| 62             | 5.8      | 1.15      | 6.1      | 1.00      | 6.6      | 0.75      | 6.9      | 0.65      | 7.0      | 0.60      |          |           |
| 60             | 6.2      | 0.95      | 6.5      | 0.80      | 6.9      | 0.60      | 7.2      | 0.50      |          |           |          |           |
| 57             | 6.6      | 0.70      | 6.9      | 0.50      |          |           |          |           |          |           |          |           |
| 55             | 7.0      | 0.50      | 7.2      | 0.40      |          |           |          |           |          |           |          |           |
| A(°)           | 45~82    |           |          |           | 52~82    |           |          |           | 60~82    |           | 75~82    |           |

| 11.8mブーム+3.3mジブ |          |           |          |           |          |           |          |           |          |           |          |           |
|-----------------|----------|-----------|----------|-----------|----------|-----------|----------|-----------|----------|-----------|----------|-----------|
| ジブオフセット         | 7°       |           | 15°      |           | 30°      |           | 45°      |           | 60°      |           | 75°      |           |
| ブーム角度 (°)       | 作業半径 (m) | 定格総荷重 (t) | 作業半径 (m) | 定格総荷重 (t) | 作業半径 (m) | 定格総荷重 (t) | 作業半径 (m) | 定格総荷重 (t) | 作業半径 (m) | 定格総荷重 (t) | 作業半径 (m) | 定格総荷重 (t) |
| 82              | 2.6      | 4.30      | 3.0      | 4.30      | 3.7      | 3.30      | 4.3      | 2.60      | 4.6      | 2.05      | 4.7      | 2.05      |
| 80              | 3.1      | 4.30      | 3.5      | 4.15      | 4.2      | 3.00      | 4.8      | 2.30      | 5.1      | 2.05      | 5.1      | 1.90      |
| 78              | 3.6      | 3.70      | 4.0      | 3.10      | 4.7      | 2.30      | 5.2      | 1.85      | 5.5      | 1.65      | 5.5      | 1.55      |
| 74              | 4.6      | 2.20      | 5.0      | 1.85      | 5.6      | 1.40      | 6.1      | 1.15      | 6.3      | 1.05      |          |           |
| 72              | 5.1      | 1.70      | 5.5      | 1.40      | 6.1      | 1.10      | 6.5      | 0.95      | 6.7      | 0.85      |          |           |
| 70              | 5.6      | 1.30      | 5.9      | 1.15      | 6.5      | 0.85      | 6.9      | 0.70      | 7.1      | 0.60      |          |           |
| 67              | 6.3      | 0.90      | 6.6      | 0.80      | 7.2      | 0.50      | 7.6      | 0.40      | 7.7      | 0.35      |          |           |
| 65              | 6.7      | 0.70      | 7.1      | 0.60      | 7.6      | 0.35      | 7.9      | 0.20      | 8.0      | 0.20      |          |           |
| A(°)            | 60~82    |           |          |           | 62~82    |           |          |           | 75~82    |           |          |           |

| 15.0mブーム+3.3mジブ |          |           |          |           |          |           |          |           |          |           |          |           |
|-----------------|----------|-----------|----------|-----------|----------|-----------|----------|-----------|----------|-----------|----------|-----------|
| ジブオフセット         | 7°       |           | 15°      |           | 30°      |           | 45°      |           | 60°      |           | 75°      |           |
| ブーム角度 (°)       | 作業半径 (m) | 定格総荷重 (t) | 作業半径 (m) | 定格総荷重 (t) | 作業半径 (m) | 定格総荷重 (t) | 作業半径 (m) | 定格総荷重 (t) | 作業半径 (m) | 定格総荷重 (t) | 作業半径 (m) | 定格総荷重 (t) |
| 82              | 3.2      | 4.00      | 3.6      | 3.15      | 4.4      | 2.50      | 4.9      | 1.55      | 5.2      | 1.60      | 5.3      | 1.60      |
| 80              | 3.8      | 3.35      | 4.3      | 2.75      | 5.0      | 1.95      | 5.5      | 1.55      | 5.8      | 1.40      | 5.8      | 1.35      |
| 78              | 4.4      | 2.40      | 4.9      | 2.00      | 5.5      | 1.50      | 6.0      | 1.20      | 6.3      | 1.10      |          |           |
| 74              | 5.6      | 1.30      | 6.0      | 1.10      | 6.7      | 0.80      | 7.1      | 0.65      |          |           |          |           |
| 72              | 6.2      | 0.90      | 6.6      | 0.75      | 7.2      | 0.55      |          |           |          |           |          |           |
| 70              | 6.8      | 0.60      | 7.2      | 0.50      |          |           |          |           |          |           |          |           |
| A(°)            | 67~82    |           |          |           | 70~82    |           |          |           | 75~82    |           |          |           |

A: ブーム角度の範囲 (無負荷時)

■ 定格総荷重表 [主巻作業] アウトリガ最小張出 (1.64m) ー側方ー

主巻作業

| 5.5mブーム+3.3mジブ |          |           |          |           |          |           |          |           |          |           |          |           |
|----------------|----------|-----------|----------|-----------|----------|-----------|----------|-----------|----------|-----------|----------|-----------|
| ジブオフセット        | 7°       |           | 15°      |           | 30°      |           | 45°      |           | 60°      |           | 75°      |           |
| ブーム角度 (°)      | 作業半径 (m) | 定格総荷重 (t) | 作業半径 (m) | 定格総荷重 (t) | 作業半径 (m) | 定格総荷重 (t) | 作業半径 (m) | 定格総荷重 (t) | 作業半径 (m) | 定格総荷重 (t) | 作業半径 (m) | 定格総荷重 (t) |
| 82             | 1.6      | 4.30      | 2.0      | 4.90      | 2.7      | 2.80      | 3.3      | 2.10      | 3.6      | 1.50      | 3.7      | 1.50      |
| 80             | 1.9      | 4.30      | 2.3      | 4.30      | 3.0      | 2.80      | 3.5      | 2.10      | 3.8      | 1.50      | 3.9      | 1.50      |
| 78             | 2.2      | 4.10      | 2.6      | 3.60      | 3.2      | 2.40      | 3.7      | 1.90      | 4.0      | 1.50      | 4.1      | 1.50      |
| 74             | 2.7      | 3.20      | 3.1      | 2.50      | 3.7      | 1.80      | 4.2      | 1.30      | 4.4      | 1.10      |          |           |
| 72             | 3.0      | 2.60      | 3.4      | 2.10      | 4.0      | 1.40      | 4.4      | 1.10      | 4.6      | 0.95      |          |           |
| 70             | 3.3      | 2.20      | 3.6      | 1.70      | 4.2      | 1.20      | 4.6      | 1.00      | 4.8      | 0.80      |          |           |
| 67             | 3.7      | 1.60      | 4.0      | 1.30      | 4.6      | 0.90      | 4.9      | 0.75      | 5.1      | 0.60      |          |           |
| 65             | 3.9      | 1.20      | 4.3      | 1.10      | 4.8      | 0.80      | 5.1      | 0.60      | 5.2      | 0.50      |          |           |
| 62             | 4.3      | 0.95      | 4.6      | 0.85      | 5.1      | 0.60      | 5.4      | 0.45      | 5.5      | 0.35      |          |           |
| 60             | 4.5      | 0.85      | 4.9      | 0.70      | 5.3      | 0.45      | 5.6      | 0.30      |          |           |          |           |
| A(°)           | 55~82    |           |          |           | 57~82    |           |          |           | 60~82    |           | 75~82    |           |

| 8.7mブーム+3.3mジブ |          |           |          |           |          |           |          |           |          |           |          |           |       |  |
|----------------|----------|-----------|----------|-----------|----------|-----------|----------|-----------|----------|-----------|----------|-----------|-------|--|
| ジブオフセット        | 7°       |           | 15°      |           | 30°      |           | 45°      |           | 60°      |           | 75°      |           |       |  |
| ブーム角度 (°)      | 作業半径 (m) | 定格総荷重 (t) | 作業半径 (m) | 定格総荷重 (t) | 作業半径 (m) | 定格総荷重 (t) | 作業半径 (m) | 定格総荷重 (t) | 作業半径 (m) | 定格総荷重 (t) | 作業半径 (m) | 定格総荷重 (t) |       |  |
| 82             | 2.1      | 3.50      | 2.5      | 2.50      | 3.2      | 1.85      | 3.7      | 1.40      | 4.1      | 1.00      | 4.2      | 1.00      |       |  |
| 80             | 2.5      | 3.50      | 2.9      | 2.50      | 3.6      | 1.85      | 4.1      | 1.40      | 4.4      | 1.00      | 4.5      | 1.00      |       |  |
| 78             | 2.9      | 2.80      | 3.3      | 2.20      | 3.9      | 1.70      | 4.4      | 1.00      | 4.7      | 0.85      | 4.8      | 0.80      |       |  |
| 74             | 3.6      | 1.50      | 4.0      | 1.15      | 4.7      | 0.75      | 5.1      | 0.55      | 5.3      | 0.45      |          |           |       |  |
| 72             | 4.0      | 1.10      | 4.4      | 0.85      | 5.0      | 0.50      | 5.4      | 0.35      |          |           |          |           |       |  |
| 70             | 4.4      | 0.80      | 4.8      | 0.60      |          |           |          |           |          |           |          |           |       |  |
| A(°)           | 65~82    |           |          |           | 67~82    |           |          |           | 70~82    |           | 72~82    |           | 75~82 |  |

| 11.8mブーム+3.3mジブ |          |           |          |           |          |           |          |           |          |           |          |           |
|-----------------|----------|-----------|----------|-----------|----------|-----------|----------|-----------|----------|-----------|----------|-----------|
| ジブオフセット         | 7°       |           | 15°      |           | 30°      |           | 45°      |           | 60°      |           | 75°      |           |
| ブーム角度 (°)       | 作業半径 (m) | 定格総荷重 (t) | 作業半径 (m) | 定格総荷重 (t) | 作業半径 (m) | 定格総荷重 (t) | 作業半径 (m) | 定格総荷重 (t) | 作業半径 (m) | 定格総荷重 (t) | 作業半径 (m) | 定格総荷重 (t) |
| 82              | 2.6      | 2.40      | 3.0      | 1.75      | 3.7      | 1.35      | 4.3      | 0.95      | 4.6      | 0.65      | 4.7      | 0.65      |
| 80              | 3.1      | 2.40      | 3.5      | 1.75      | 4.2      | 1.20      | 4.8      | 0.80      | 5.1      | 0.65      | 5.1      | 0.60      |
| 78              | 3.6      | 1.60      | 4.0      | 1.20      | 4.7      | 0.80      | 5.2      | 0.50      | 5.5      | 0.40      | 5.5      | 0.40      |
| 74              | 4.6      | 0.60      | 5.0      | 0.45      |          |           |          |           |          |           |          |           |
| A(°)            | 70~82    |           | 72~82    |           |          |           | 74~82    |           |          |           | 75~82    |           |

| 15.0mブーム+3.3mジブ |          |           |          |           |          |           |          |           |          |           |          |           |
|-----------------|----------|-----------|----------|-----------|----------|-----------|----------|-----------|----------|-----------|----------|-----------|
| ジブオフセット         | 7°       |           | 15°      |           | 30°      |           | 45°      |           | 60°      |           | 75°      |           |
| ブーム角度 (°)       | 作業半径 (m) | 定格総荷重 (t) | 作業半径 (m) | 定格総荷重 (t) | 作業半径 (m) | 定格総荷重 (t) | 作業半径 (m) | 定格総荷重 (t) | 作業半径 (m) | 定格総荷重 (t) | 作業半径 (m) | 定格総荷重 (t) |
| 82              | 3.2      | 1.70      | 3.6      | 1.20      | 4.4      | 0.90      |          |           |          |           |          |           |
| 80              | 3.8      | 1.40      | 4.3      | 1.00      | 5.0      | 0.60      |          |           |          |           |          |           |
| 78              | 4.4      | 0.80      | 4.9      | 0.60      |          |           |          |           |          |           |          |           |
| A(°)            | 74~82    |           |          |           | 78~82    |           |          |           |          |           |          |           |

A: ブーム角度の範囲 (無負荷時)

(注意)

1. 定格総荷重は、水平堅土上においてクレーンを水平に設置した状態での値で、つり具と主巻フック質量 (75kg) を含んだ値です。太線より上はクレーンの強度によって定められ、下はクレーンの安定度によって定められています。
2. ブームの角度を基準にしてください。なお、作業半径は、ブームのたわみを含んだ参考値を示します。
3. 主巻作業時は、補巻フックが主巻フックと干渉しない程度にジブ長さを4.1m~6.5mの間で調整してください。
4. 主巻作業におけるフックのワイヤロープ標準巻掛本数は4本です。
5. 側方域でのつり上げ性能は、アウトリガ張出幅によって異なります。張出幅に応じた性能で作業をしてください。また、前方・後方域でのつり上げ性能は「アウトリガ最大張出」の定格総荷重ですが、アウトリガ張出幅によってその前方・後方域の範囲(角度 a)が異なります。

| 張出幅   | 中間張出 (4.3m) | 中間張出 (3.5m) | 中間張出 (2.5m) | 最小張出 (1.64m) |
|-------|-------------|-------------|-------------|--------------|
| 角度 a° | 35          | 25          | 15          | 5            |

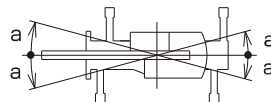

| 15.0mブーム+4.1mジブ |          |           |          |           |          |           |          |           |          |           |          |           |
|-----------------|----------|-----------|----------|-----------|----------|-----------|----------|-----------|----------|-----------|----------|-----------|
| ジブオフセット         | ※7°      |           | ※15°     |           | 30°      |           | 45°      |           | 60°      |           | 75°      |           |
| ブーム角度 (°)       | 作業半径 (m) | 定格総荷重 (t) | 作業半径 (m) | 定格総荷重 (t) | 作業半径 (m) | 定格総荷重 (t) | 作業半径 (m) | 定格総荷重 (t) | 作業半径 (m) | 定格総荷重 (t) | 作業半径 (m) | 定格総荷重 (t) |
| 82              | 3.3      | 1.80      | 4.0      | 1.80      | 4.6      | 1.80      | 5.4      | 1.80      | 5.9      | 1.80      | 6.1      | 1.80      |
| 80              | 4.0      | 1.80      | 4.7      | 1.80      | 5.3      | 1.80      | 6.0      | 1.80      | 6.4      | 1.80      | 6.6      | 1.80      |
| 78              | 4.8      | 1.80      | 5.3      | 1.80      | 5.9      | 1.80      | 6.6      | 1.80      | 7.0      | 1.80      | 7.1      | 1.80      |
| 74              | 6.1      | 1.80      | 6.7      | 1.80      | 7.1      | 1.80      | 7.7      | 1.80      | 8.1      | 1.80      |          |           |
| 72              | 6.8      | 1.80      | 7.4      | 1.80      | 7.7      | 1.80      | 8.2      | 1.80      | 8.6      | 1.70      |          |           |
| 70              | 7.5      | 1.75      | 8.0      | 1.75      | 8.2      | 1.80      | 8.8      | 1.70      | 9.1      | 1.60      |          |           |
| 67              | 8.4      | 1.65      | 8.9      | 1.55      | 9.1      | 1.60      | 9.6      | 1.50      | 9.8      | 1.40      |          |           |
| 65              | 9.0      | 1.50      | 9.5      | 1.40      | 9.6      | 1.40      | 10.1     | 1.35      | 10.3     | 1.25      |          |           |
| 62              | 9.9      | 1.25      | 10.4     | 1.20      | 10.4     | 1.20      | 10.8     | 1.15      | 11.0     | 1.10      |          |           |
| 60              |          |           | 10.9     | 1.05      | 10.9     | 1.05      | 11.3     | 1.00      |          |           |          |           |
| 57              |          |           |          |           |          |           | 12.0     | 0.85      |          |           |          |           |
| A(°)            | 45~82    |           |          |           | 60~82    |           |          |           | 75~82    |           |          |           |

| 15.0mブーム+6.5mジブ |          |           |          |           |          |           |          |           |          |           |          |           |
|-----------------|----------|-----------|----------|-----------|----------|-----------|----------|-----------|----------|-----------|----------|-----------|
| ジブオフセット         | 7°       |           | 15°      |           | 30°      |           | 45°      |           | 60°      |           | 75°      |           |
| ブーム角度 (°)       | 作業半径 (m) | 定格総荷重 (t) | 作業半径 (m) | 定格総荷重 (t) | 作業半径 (m) | 定格総荷重 (t) | 作業半径 (m) | 定格総荷重 (t) | 作業半径 (m) | 定格総荷重 (t) | 作業半径 (m) | 定格総荷重 (t) |
| 82              | 4.0      | 1.80      | 4.8      | 1.80      | 6.3      | 1.80      | 7.5      | 1.80      | 8.3      | 1.80      | 8.6      | 1.75      |
| 80              | 4.7      | 1.80      | 5.6      | 1.80      | 7.0      | 1.80      | 8.1      | 1.80      | 8.8      | 1.80      | 9.1      | 1.75      |
| 78              | 5.5      | 1.80      | 6.3      | 1.80      | 7.7      | 1.80      | 8.8      | 1.80      | 9.4      | 1.70      | 9.6      | 1.70      |
| 74              | 6.9      | 1.80      | 7.7      | 1.80      | 9.0      | 1.75      | 10.0     | 1.50      | 10.5     | 1.40      |          |           |
| 72              | 7.6      | 1.80      | 8.3      | 1.80      | 9.6      | 1.55      | 10.6     | 1.35      | 11.1     | 1.25      |          |           |
| 70              | 8.2      | 1.70      | 9.0      | 1.65      | 10.3     | 1.35      | 11.2     | 1.20      | 11.6     | 1.15      |          |           |
| 67              | 9.2      | 1.45      | 10.0     | 1.35      | 11.2     | 1.15      | 12.0     | 1.05      | 12.4     | 1.00      |          |           |
| 65              | 9.9      | 1.30      | 10.6     | 1.20      | 11.8     | 1.05      | 12.5     | 0.95      | 12.8     | 0.90      |          |           |
| 62              | 10.8     | 1.10      | 11.5     | 1.05      | 12.6     | 0.85      | 13.3     | 0.80      |          |           |          |           |
| 60              | 11.5     | 1.00      | 12.1     | 0.90      | 13.2     | 0.75      | 13.8     | 0.70      |          |           |          |           |
| 57              |          |           | 13.0     | 0.75      | 14.0     | 0.60      |          |           |          |           |          |           |
| A(°)            | 50~82    |           | 45~82    |           |          |           | 60~82    |           | 75~82    |           |          |           |

| 15.0mブーム+8.9mジブ |          |           |          |           |          |           |          |           |          |           |          |           |
|-----------------|----------|-----------|----------|-----------|----------|-----------|----------|-----------|----------|-----------|----------|-----------|
| ジブオフセット         | 7°       |           | 15°      |           | 30°      |           | 45°      |           | 60°      |           | 75°      |           |
| ブーム角度 (°)       | 作業半径 (m) | 定格総荷重 (t) | 作業半径 (m) | 定格総荷重 (t) | 作業半径 (m) | 定格総荷重 (t) | 作業半径 (m) | 定格総荷重 (t) | 作業半径 (m) | 定格総荷重 (t) | 作業半径 (m) | 定格総荷重 (t) |
| 82              | 4.7      | 1.20      | 5.9      | 1.20      | 7.9      | 1.20      | 9.5      | 1.20      | 10.5     | 1.20      | 11.0     | 1.15      |
| 80              | 5.5      | 1.20      | 6.7      | 1.20      | 8.7      | 1.20      | 10.2     | 1.20      | 11.2     | 1.20      | 11.5     | 1.15      |
| 78              | 6.3      | 1.20      | 7.4      | 1.20      | 9.4      | 1.20      | 10.8     | 1.20      | 11.8     | 1.20      | 12.0     | 1.15      |
| 74              | 7.8      | 1.20      | 9.0      | 1.20      | 10.8     | 1.20      | 12.2     | 1.20      | 12.9     | 1.05      |          |           |
| 72              | 8.6      | 1.10      | 9.7      | 1.20      | 11.5     | 1.20      | 12.8     | 1.05      | 13.5     | 0.95      |          |           |
| 70              | 9.4      | 1.00      | 10.5     | 1.10      | 12.2     | 1.10      | 13.4     | 0.95      | 14.0     | 0.90      |          |           |
| 67              | 10.5     | 0.80      | 11.5     | 1.00      | 13.2     | 0.90      | 14.3     | 0.80      | 14.8     | 0.80      |          |           |
| 65              | 11.2     | 0.70      | 12.2     | 0.90      | 13.8     | 0.80      | 14.9     | 0.70      | 15.3     | 0.70      |          |           |
| 62              | 12.3     | 0.60      | 13.2     | 0.80      | 14.8     | 0.70      | 15.7     | 0.55      | 16.0     | 0.55      |          |           |
| 60              | 12.9     | 0.55      | 13.9     | 0.70      | 15.3     | 0.60      | 16.2     | 0.45      |          |           |          |           |
| 57              |          |           |          |           | 16.2     | 0.40      | 16.9     | 0.35      |          |           |          |           |
| A(°)            | 45~82    |           |          |           | 60~82    |           |          |           | 75~82    |           |          |           |

| 15.0mブーム+13.6mジブ |          |           |          |           |          |           |          |           |          |           |          |           |  |
|------------------|----------|-----------|----------|-----------|----------|-----------|----------|-----------|----------|-----------|----------|-----------|--|
| ジブオフセット          | 7°       |           | 15°      |           | 30°      |           | 45°      |           | 60°      |           | 75°      |           |  |
| ブーム角度 (°)        | 作業半径 (m) | 定格総荷重 (t) | 作業半径 (m) | 定格総荷重 (t) | 作業半径 (m) | 定格総荷重 (t) | 作業半径 (m) | 定格総荷重 (t) | 作業半径 (m) | 定格総荷重 (t) | 作業半径 (m) | 定格総荷重 (t) |  |
| 82               | 6.1      | 0.70      | 7.9      | 0.70      | 11.0     | 0.70      | 13.4     | 0.65      | 14.9     | 0.58      | 15.6     | 0.55      |  |
| 80               | 7.0      | 0.70      | 8.8      | 0.70      | 11.9     | 0.70      | 14.2     | 0.65      | 15.6     | 0.58      | 16.1     | 0.55      |  |
| 78               | 8.0      | 0.70      | 9.7      | 0.70      | 12.7     | 0.70      | 14.9     | 0.65      | 16.3     | 0.58      | 16.7     | 0.55      |  |
| 74               | 9.9      | 0.70      | 11.6     | 0.70      | 14.4     | 0.70      | 16.4     | 0.61      | 17.5     | 0.57      |          |           |  |
| 72               | 10.8     | 0.60      | 12.4     | 0.65      | 15.2     | 0.70      | 17.1     | 0.59      | 18.1     | 0.56      |          |           |  |
| 70               | 11.7     | 0.50      | 13.3     | 0.60      | 16.0     | 0.70      | 17.8     | 0.56      | 18.7     | 0.55      |          |           |  |
| 67               | 13.0     | 0.45      | 14.6     | 0.52      | 17.1     | 0.70      | 18.8     | 0.51      | 19.5     | 0.45      |          |           |  |
| 65               | 13.9     | 0.35      | 15.4     | 0.48      | 17.8     | 0.55      | 19.4     | 0.45      | 20.0     | 0.35      |          |           |  |
| 62               | 15.1     | 0.30      | 16.6     | 0.42      | 18.9     | 0.40      |          |           |          |           |          |           |  |
| 60               | 15.9     | 0.25      |          |           | 19.6     | 0.30      |          |           |          |           |          |           |  |
| A(°)             | 50~82    |           |          |           | 55~82    |           |          |           | 60~82    |           | 75~82    |           |  |

| 15.0mブーム+15.9mジブ |          |           |          |           |          |           |          |           |          |           |          |           |  |
|------------------|----------|-----------|----------|-----------|----------|-----------|----------|-----------|----------|-----------|----------|-----------|--|
| ジブオフセット          | 7°       |           | 15°      |           | 30°      |           | 45°      |           | 60°      |           | 75°      |           |  |
| ブーム角度 (°)        | 作業半径 (m) | 定格総荷重 (t) | 作業半径 (m) | 定格総荷重 (t) | 作業半径 (m) | 定格総荷重 (t) | 作業半径 (m) | 定格総荷重 (t) | 作業半径 (m) | 定格総荷重 (t) | 作業半径 (m) | 定格総荷重 (t) |  |
| 82               | 6.8      | 0.65      | 8.8      | 0.65      | 12.3     | 0.40      | 15.1     | 0.30      | 17.0     | 0.27      | 17.9     | 0.27      |  |
| 80               | 7.8      | 0.65      | 9.9      | 0.65      | 13.3     | 0.40      | 16.0     | 0.30      | 17.7     | 0.27      | 18.4     | 0.27      |  |
| 78               | 8.9      | 0.65      | 10.9     | 0.60      | 14.2     | 0.40      | 16.8     | 0.30      | 18.4     | 0.27      | 19.0     | 0.27      |  |
| 74               | 10.9     | 0.55      | 12.8     | 0.52      | 16.0     | 0.37      | 18.3     | 0.30      | 19.7     | 0.27      |          |           |  |
| 72               | 11.9     | 0.45      | 13.8     | 0.49      | 16.8     | 0.36      | 19.1     | 0.29      | 20.3     | 0.27      |          |           |  |
| 70               | 12.8     | 0.40      | 14.7     | 0.46      | 17.7     | 0.35      | 19.8     | 0.28      | 20.9     | 0.27      |          |           |  |
| 67               | 14.3     | 0.33      | 16.1     | 0.42      | 18.9     | 0.33      | 20.8     | 0.27      | 21.7     | 0.27      |          |           |  |
| 65               | 15.2     | 0.28      | 17.0     | 0.38      | 19.7     | 0.32      | 21.5     | 0.26      | 22.3     | 0.27      |          |           |  |
| 62               | 16.6     | 0.22      | 18.2     | 0.34      | 20.8     | 0.30      | 22.4     | 0.25      | 23.0     | 0.27      |          |           |  |
| 60               | 17.4     | 0.18      | 19.1     | 0.31      | 21.5     | 0.28      | 23.0     | 0.25      |          |           |          |           |  |
| A(°)             | 50~82    |           |          |           | 55~82    |           |          |           | 60~82    |           | 75~82    |           |  |

A: ブーム角度の範囲 (無負荷時)

| ジブオフセット   | ※7°      |           | ※15°     |           | 30°      |           | 45°      |           | 60°      |           | 75°      |           |
|-----------|----------|-----------|----------|-----------|----------|-----------|----------|-----------|----------|-----------|----------|-----------|
| ブーム角度 (°) | 作業半径 (m) | 定格総荷重 (t) | 作業半径 (m) | 定格総荷重 (t) | 作業半径 (m) | 定格総荷重 (t) | 作業半径 (m) | 定格総荷重 (t) | 作業半径 (m) | 定格総荷重 (t) | 作業半径 (m) | 定格総荷重 (t) |
| 82        | 2.8      | 1.80      | 3.4      | 1.80      | 4.0      | 1.80      | 4.8      | 1.80      | 5.3      | 1.80      | 5.5      | 1.80      |
| 80        | 3.4      | 1.80      | 3.9      | 1.80      | 4.5      | 1.80      | 5.3      | 1.80      | 5.7      | 1.80      | 5.9      | 1.80      |
| 78        | 3.9      | 1.80      | 4.6      | 1.80      | 5.1      | 1.80      | 5.7      | 1.80      | 6.2      | 1.80      |          |           |
| 74        | 5.1      | 1.80      | 5.7      | 1.80      | 6.0      | 1.80      | 6.7      | 1.80      | 7.0      | 1.80      |          |           |
| 72        | 5.6      | 1.80      | 6.1      | 1.80      | 6.5      | 1.80      | 7.1      | 1.80      | 7.4      | 1.80      |          |           |
| 70        | 6.1      | 1.80      | 6.7      | 1.80      | 7.0      | 1.80      | 7.6      | 1.80      | 7.9      | 1.80      |          |           |
| 67        | 6.9      | 1.65      | 7.5      | 1.80      | 7.7      | 1.80      | 8.2      | 1.80      | 8.4      | 1.75      |          |           |
| 65        | 7.5      | 1.60      | 8.0      | 1.70      | 8.1      | 1.80      | 8.6      | 1.70      | 8.8      | 1.70      |          |           |
| 62        | 8.2      | 1.55      | 8.7      | 1.60      | 8.8      | 1.65      | 9.2      | 1.50      |          |           |          |           |
| 60        | 8.7      | 1.45      | 9.2      | 1.50      | 9.2      | 1.55      | 9.6      | 1.40      |          |           |          |           |
| 57        | 9.4      | 1.30      | 9.9      | 1.30      | 9.8      | 1.35      | 10.1     | 1.25      |          |           |          |           |
| 55        | 9.8      | 1.15      | 10.3     | 1.20      | 10.2     | 1.25      | 10.5     | 1.15      |          |           |          |           |
| 52        | 10.5     | 1.05      | 11.0     | 1.05      | 10.7     | 1.10      | 11.0     | 1.05      |          |           |          |           |
| 50        | 10.9     | 0.95      |          |           | 11.1     | 1.00      |          |           |          |           |          |           |
| 45        |          |           |          |           | 11.9     | 0.83      |          |           |          |           |          |           |
| A(°)      | 30~82    |           | 25~82    |           | 30~82    |           | 45~82    |           | 60~82    |           | 75~82    |           |

| ジブオフセット   | 7°       |           | 15°      |           | 30°      |           | 45°      |           | 60°      |           | 75°      |           |
|-----------|----------|-----------|----------|-----------|----------|-----------|----------|-----------|----------|-----------|----------|-----------|
| ブーム角度 (°) | 作業半径 (m) | 定格総荷重 (t) | 作業半径 (m) | 定格総荷重 (t) | 作業半径 (m) | 定格総荷重 (t) | 作業半径 (m) | 定格総荷重 (t) | 作業半径 (m) | 定格総荷重 (t) | 作業半径 (m) | 定格総荷重 (t) |
| 82        | 3.3      | 1.80      | 4.2      | 1.80      | 5.6      | 1.80      | 6.8      | 1.80      | 7.6      | 1.80      | 8.0      | 1.80      |
| 80        | 4.0      | 1.80      | 4.8      | 1.80      | 6.2      | 1.80      | 7.3      | 1.80      | 8.1      | 1.80      | 8.4      | 1.80      |
| 78        | 4.6      | 1.80      | 5.4      | 1.80      | 6.8      | 1.80      | 7.9      | 1.80      | 8.6      | 1.80      | 8.8      | 1.80      |
| 74        | 5.8      | 1.80      | 6.6      | 1.80      | 7.9      | 1.80      | 8.9      | 1.80      | 9.5      | 1.70      |          |           |
| 72        | 6.4      | 1.80      | 7.1      | 1.80      | 8.4      | 1.80      | 9.4      | 1.70      | 9.9      | 1.55      |          |           |
| 70        | 6.9      | 1.75      | 7.7      | 1.80      | 9.0      | 1.75      | 9.9      | 1.55      | 10.3     | 1.45      |          |           |
| 67        | 7.8      | 1.45      | 8.5      | 1.80      | 9.7      | 1.55      | 10.5     | 1.35      | 10.9     | 1.30      |          |           |
| 65        | 8.3      | 1.35      | 9.1      | 1.55      | 10.2     | 1.40      | 11.0     | 1.25      | 11.3     | 1.20      |          |           |
| 62        | 9.2      | 1.20      | 9.9      | 1.35      | 10.9     | 1.20      | 11.6     | 1.10      | 11.9     | 1.05      |          |           |
| 60        | 9.7      | 1.05      | 10.4     | 1.25      | 11.4     | 1.10      | 12.0     | 1.05      | 12.2     | 1.00      |          |           |
| 57        | 10.4     | 0.93      | 11.1     | 1.10      | 12.1     | 1.00      | 12.6     | 0.95      |          |           |          |           |
| 55        | 10.9     | 0.85      | 11.6     | 1.00      | 12.5     | 0.90      | 13.0     | 0.85      |          |           |          |           |
| 52        | 11.6     | 0.78      | 12.2     | 0.88      | 13.1     | 0.80      | 13.5     | 0.75      |          |           |          |           |
| 50        | 12.1     | 0.73      | 12.7     | 0.80      | 13.5     | 0.70      | 13.8     | 0.65      |          |           |          |           |
| 45        | 13.2     | 0.63      |          |           |          |           |          |           |          |           |          |           |
| A(°)      | 30~82    |           | 25~82    |           | 30~82    |           | 45~82    |           | 60~82    |           | 75~82    |           |

| ジブオフセット   | 7°       |           | 15°      |           | 30°      |           | 45°      |           | 60°      |           | 75°      |           |
|-----------|----------|-----------|----------|-----------|----------|-----------|----------|-----------|----------|-----------|----------|-----------|
| ブーム角度 (°) | 作業半径 (m) | 定格総荷重 (t) | 作業半径 (m) | 定格総荷重 (t) | 作業半径 (m) | 定格総荷重 (t) | 作業半径 (m) | 定格総荷重 (t) | 作業半径 (m) | 定格総荷重 (t) | 作業半径 (m) | 定格総荷重 (t) |
| 82        | 4.0      | 1.20      | 5.2      | 1.20      | 7.2      | 1.20      | 8.8      | 1.20      | 9.9      | 1.20      | 10.3     | 1.20      |
| 80        | 4.7      | 1.20      | 5.9      | 1.20      | 7.8      | 1.20      | 9.4      | 1.20      | 10.4     | 1.20      | 10.8     | 1.20      |
| 78        | 5.4      | 1.20      | 6.5      | 1.20      | 8.5      | 1.20      | 9.9      | 1.20      | 10.9     | 1.20      | 11.2     | 1.20      |
| 74        | 6.8      | 1.20      | 7.9      | 1.20      | 9.7      | 1.20      | 11.0     | 1.20      | 11.8     | 1.20      |          |           |
| 72        | 7.4      | 1.15      | 8.5      | 1.20      | 10.3     | 1.20      | 11.6     | 1.20      | 12.3     | 1.20      |          |           |
| 70        | 8.1      | 1.00      | 9.1      | 1.15      | 10.9     | 1.20      | 12.1     | 1.20      | 12.7     | 1.10      |          |           |
| 67        | 9.0      | 0.85      | 10.1     | 1.00      | 11.7     | 1.15      | 12.8     | 1.05      | 13.4     | 1.00      |          |           |
| 65        | 9.7      | 0.75      | 10.7     | 0.93      | 12.3     | 1.10      | 13.3     | 0.98      | 13.8     | 0.95      |          |           |
| 62        | 10.6     | 0.65      | 11.5     | 0.85      | 13.0     | 1.00      | 14.0     | 0.85      |          |           |          |           |
| 60        | 11.2     | 0.60      | 12.1     | 0.80      | 13.5     | 0.90      | 14.4     | 0.80      |          |           |          |           |
| 57        | 12.0     | 0.50      | 12.9     | 0.70      | 14.3     | 0.75      | 15.0     | 0.70      |          |           |          |           |
| 55        | 12.6     | 0.45      | 13.4     | 0.68      | 14.7     | 0.70      | 15.4     | 0.63      |          |           |          |           |
| 52        | 13.4     | 0.40      | 14.2     | 0.63      | 15.4     | 0.57      | 15.9     | 0.51      |          |           |          |           |
| 50        | 13.9     | 0.37      | 14.7     | 0.59      | 15.8     | 0.50      | 16.2     | 0.45      |          |           |          |           |
| A(°)      | 35~82    |           | 25~82    |           | 30~82    |           | 45~82    |           | 60~82    |           | 75~82    |           |

| ジブオフセット   | 7°       |           | 15°      |           | 30°      |           | 45°      |           | 60°      |           | 75°      |           |
|-----------|----------|-----------|----------|-----------|----------|-----------|----------|-----------|----------|-----------|----------|-----------|
| ブーム角度 (°) | 作業半径 (m) | 定格総荷重 (t) | 作業半径 (m) | 定格総荷重 (t) | 作業半径 (m) | 定格総荷重 (t) | 作業半径 (m) | 定格総荷重 (t) | 作業半径 (m) | 定格総荷重 (t) | 作業半径 (m) | 定格総荷重 (t) |
| 82        | 5.4      | 0.70      | 7.2      | 0.70      | 10.2     | 0.70      | 12.7     | 0.70      | 14.3     | 0.58      | 15.0     | 0.55      |
| 80        | 6.2      | 0.70      | 8.0      | 0.70      | 11.0     | 0.70      | 13.4     | 0.69      | 14.8     | 0.58      | 15.5     | 0.55      |
| 78        | 7.1      | 0.70      | 8.8      | 0.70      | 11.8     | 0.70      | 14.0     | 0.67      | 15.4     | 0.58      |          |           |
| 74        | 8.7      | 0.70      | 10.4     | 0.70      | 13.2     | 0.70      | 15.3     | 0.65      | 16.4     | 0.57      |          |           |
| 72        | 9.5      | 0.65      | 11.2     | 0.70      | 13.9     | 0.70      | 15.9     | 0.63      | 16.9     | 0.57      |          |           |
| 70        | 10.3     | 0.55      | 12.0     | 0.60      | 14.6     | 0.70      | 16.5     | 0.61      | 17.4     | 0.56      |          |           |
| 67        | 11.5     | 0.45      | 13.1     | 0.55      | 15.6     | 0.70      | 17.3     | 0.59      | 18.0     | 0.55      |          |           |
| 65        | 12.3     | 0.39      | 13.8     | 0.50      | 16.2     | 0.68      | 17.8     | 0.58      | 18.5     | 0.55      |          |           |
| 62        | 13.4     | 0.33      | 14.9     | 0.45      | 17.1     | 0.62      | 18.6     | 0.54      | 19.0     | 0.54      |          |           |
| 60        | 14.1     | 0.29      | 15.5     | 0.42      | 17.7     | 0.58      | 19.0     | 0.50      |          |           |          |           |
| 57        | 15.2     | 0.24      |          |           |          |           | 19.7     | 0.35      |          |           |          |           |
| A(°)      | 40~82    |           | 35~82    |           | 45~82    |           | 60~82    |           | 75~82    |           |          |           |

| ジブオフセット   | 7°       |           | 15°      |           | 30°      |           | 45°      |           | 60°      |           | 75°      |           |
|-----------|----------|-----------|----------|-----------|----------|-----------|----------|-----------|----------|-----------|----------|-----------|
| ブーム角度 (°) | 作業半径 (m) | 定格総荷重 (t) | 作業半径 (m) | 定格総荷重 (t) | 作業半径 (m) | 定格総荷重 (t) | 作業半径 (m) | 定格総荷重 (t) | 作業半径 (m) | 定格総荷重 (t) | 作業半径 (m) | 定格総荷重 (t) |
| 82        | 6.1      | 0.65      | 8.1      | 0.65      | 11.6     | 0.40      | 14.5     | 0.30      | 16.4     | 0.27      | 17.3     | 0.27      |
| 80        | 7.0      | 0.65      | 9.0      | 0.65      | 12.5     | 0.40      | 15.2     | 0.30      | 17.0     | 0.27      | 17.7     | 0.27      |
| 78        | 7.9      | 0.65      | 9.9      | 0.60      | 13.3     | 0.40      | 15.9     | 0.30      | 17.6     | 0.27      | 18.2     | 0.27      |
| 74        | 9.8      | 0.60      | 11.7     | 0.53      | 14.9     | 0.40      | 17.3     | 0.30      | 18.7     | 0.27      |          |           |
| 72        | 10.6     | 0.48      | 12.5     | 0.51      | 15.6     | 0.37      | 17.9     | 0.29      | 19.2     | 0.27      |          |           |
| 70        | 11.5     | 0.42      | 13.4     | 0.48      | 16.4     | 0.35      | 18.5     | 0.28      | 19.7     | 0.27      |          |           |
| 67        | 12.8     | 0.32      | 14.6     | 0.42      | 17.4     | 0.33      | 19.4     | 0.28      | 20.3     | 0.27      |          |           |
| 65        | 13.6     | 0.27      | 15.4     | 0.38      | 18.1     | 0.32      | 20.0     | 0.27      | 20.8     | 0.27      |          |           |
| 62        | 14.8     | 0.20      | 16.5     | 0.34      | 19.1     | 0.30      | 20.8     | 0.26      |          |           |          |           |
| 60        |          |           | 17.2     | 0.32      | 19.7     | 0.29      | 21.3     | 0.26      |          |           |          |           |
| 57        |          |           |          |           |          |           | 21.9     | 0.25      |          |           |          |           |
| A(°)      |          |           | 45~82    |           | 50~82    |           | 60~82    |           | 75~82    |           |          |           |

| ジブオフセット   | ※7°      |           | ※15°     |           | 30°      |           | 45°      |           | 60°      |           | 75°      |           |
|-----------|----------|-----------|----------|-----------|----------|-----------|----------|-----------|----------|-----------|----------|-----------|
| ブーム角度 (°) | 作業半径 (m) | 定格総荷重 (t) | 作業半径 (m) | 定格総荷重 (t) | 作業半径 (m) | 定格総荷重 (t) | 作業半径 (m) | 定格総荷重 (t) | 作業半径 (m) | 定格総荷重 (t) | 作業半径 (m) | 定格総荷重 (t) |
| 82        | 2.3      | 1.80      | 2.9      | 1.80      | 3.5      | 1.80      | 4.2      | 1.80      | 4.8      | 1.80      | 5.0      | 1.80      |
| 80        | 2.8      | 1.80      | 3.4      | 1.80      | 3.9      | 1.80      | 4.6      | 1.80      | 5.1      | 1.80      | 5.3      | 1.80      |
| 78        | 3.2      | 1.80      | 3.9      | 1.80      | 4.3      | 1.80      | 5.0      | 1.80      | 5.4      | 1.80      | 5.6      | 1.80      |
| 74        | 4.1      | 1.80      | 4.7      | 1.80      | 5.1      | 1.80      | 5.7      | 1.80      | 6.1      | 1.80      |          |           |
| 72        | 4.6      | 1.80      | 5.2      | 1.80      | 5.5      | 1.80      | 6.1      | 1.80      | 6.4      | 1.80      |          |           |
| 70        | 5.0      | 1.80      | 5.6      | 1.80      | 5.8      | 1.80      | 6.4      | 1.80      | 6.7      | 1.80      |          |           |
| 67        | 5.6      | 1.70      | 6.2      | 1.75      | 6.4      | 1.80      | 6.9      | 1.80      | 7.1      | 1.80      |          |           |
| 65        | 6.1      | 1.65      | 6.6      | 1.70      | 6.7      | 1.80      | 7.2      | 1.80      |          |           |          |           |
| 62        | 6.7      | 1.60      | 7.2      | 1.65      | 7.2      | 1.80      | 7.7      | 1.80      |          |           |          |           |
| 60        | 7.1      | 1.55      | 7.6      | 1.65      | 7.5      | 1.80      | 7.9      | 1.80      |          |           |          |           |
| 57        | 7.7      | 1.50      | 8.1      | 1.60      | 8.0      | 1.80      | 8.4      | 1.70      |          |           |          |           |
| 55        | 8.0      | 1.45      | 8.5      | 1.55      | 8.3      | 1.75      | 8.6      | 1.65      |          |           |          |           |
| 52        | 8.5      | 1.40      | 9.0      | 1.45      | 8.7      | 1.60      | 9.0      | 1.55      |          |           |          |           |
| 50        | 8.9      | 1.35      |          |           | 9.0      | 1.55      |          |           |          |           |          |           |
| A(°)      | 7~82     |           | 15~82    |           | 30~82    |           | 45~82    |           | 60~82    |           | 75~82    |           |

| ジブオフセット   | 7°       |           | 15°      |           | 30°      |           | 45°      |           | 60°      |           | 75°      |           |
|-----------|----------|-----------|----------|-----------|----------|-----------|----------|-----------|----------|-----------|----------|-----------|
| ブーム角度 (°) | 作業半径 (m) | 定格総荷重 (t) | 作業半径 (m) | 定格総荷重 (t) | 作業半径 (m) | 定格総荷重 (t) | 作業半径 (m) | 定格総荷重 (t) | 作業半径 (m) | 定格総荷重 (t) | 作業半径 (m) | 定格総荷重 (t) |
| 82        | 2.8      | 1.80      | 3.6      | 1.80      | 5.1      | 1.80      | 6.2      | 1.80      | 7.1      | 1.80      | 7.4      | 1.80      |
| 80        | 3.3      | 1.80      | 4.1      | 1.80      | 5.5      | 1.80      | 6.7      | 1.80      | 7.4      | 1.80      | 7.8      | 1.80      |
| 78        | 3.8      | 1.80      | 4.6      | 1.80      | 6.0      | 1.80      | 7.1      | 1.80      | 7.8      | 1.80      | 8.1      | 1.80      |
| 74        | 4.8      | 1.80      | 5.6      | 1.80      | 6.9      | 1.80      | 7.9      | 1.80      | 8.5      | 1.80      |          |           |
| 72        | 5.3      | 1.80      | 6.0      | 1.80      | 7.3      | 1.80      | 8.3      | 1.80      | 8.8      | 1.80      |          |           |
| 70        | 5.7      | 1.80      | 6.5      | 1.80      | 7.8      | 1.80      | 8.7      | 1.80      | 9.1      | 1.80      |          |           |
| 67        | 6.4      | 1.50      | 7.2      | 1.70      | 8.4      | 1.80      | 9.2      | 1.75      | 9.6      | 1.65      |          |           |
| 65        | 6.9      | 1.35      | 7.6      | 1.60      | 8.8      | 1.80      | 9.5      | 1.60      | 9.9      | 1.55      |          |           |
| 62        | 7.6      | 1.20      | 8.3      | 1.45      | 9.3      | 1.65      | 10.0     | 1.50      |          |           |          |           |
| 60        | 8.0      | 1.10      | 8.7      | 1.35      | 9.7      | 1.55      | 10.3     | 1.40      |          |           |          |           |
| 57        | 8.6      | 0.95      | 9.3      | 1.25      | 10.2     | 1.45      | 10.8     | 1.30      |          |           |          |           |
| 55        | 9.0      | 0.90      | 9.6      | 1.15      | 10.6     | 1.35      | 11.1     | 1.25      |          |           |          |           |
| 52        | 9.6      | 0.80      | 10.2     | 1.05      | 11.0     | 1.25      | 11.4     | 1.15      |          |           |          |           |
| 50        | 10.0     | 0.75      | 10.5     | 1.00      | 11.3     | 1.15      | 11.7     | 1.10      |          |           |          |           |
| 45        |          |           |          |           | 12.0     | 1.00      |          |           |          |           |          |           |
| A(°)      | 7~82     |           | 15~82    |           | 30~82    |           | 45~82    |           | 60~82    |           | 75~82    |           |

| ジブオフセット   | 7°       |           | 15°      |           | 30°      |           | 45°      |           | 60°      |           | 75°      |           |
|-----------|----------|-----------|----------|-----------|----------|-----------|----------|-----------|----------|-----------|----------|-----------|
| ブーム角度 (°) | 作業半径 (m) | 定格総荷重 (t) | 作業半径 (m) | 定格総荷重 (t) | 作業半径 (m) | 定格総荷重 (t) | 作業半径 (m) | 定格総荷重 (t) | 作業半径 (m) | 定格総荷重 (t) | 作業半径 (m) | 定格総荷重 (t) |
| 82        | 3.4      | 1.20      | 4.6      | 1.20      | 6.6      | 1.20      | 8.2      | 1.20      | 9.3      | 1.20      | 9.8      | 1.20      |
| 80        | 4.0      | 1.20      | 5.2      | 1.20      | 7.1      | 1.20      | 8.7      | 1.20      | 9.7      | 1.20      | 10.2     | 1.20      |
| 78        | 4.6      | 1.20      | 5.7      | 1.20      | 7.7      | 1.20      | 9.2      | 1.20      | 10.1     | 1.20      |          |           |
| 74        | 5.8      | 1.20      | 6.8      | 1.20      | 8.7      | 1.20      | 10.0     | 1.20      | 10.8     | 1.20      |          |           |
| 72        | 6.3      | 1.20      | 7.4      | 1.15      | 9.2      | 1.20      | 10.5     | 1.20      | 11.2     | 1.20      |          |           |
| 70        | 6.9      | 1.00      | 7.9      | 1.15      | 9.6      | 1.20      | 10.9     | 1.20      | 11.5     | 1.20      |          |           |
| 67        | 7.7      | 0.85      | 8.7      | 1.05      | 10.3     | 1.20      | 11.5     | 1.20      | 12.0     | 1.20      |          |           |
| 65        | 8.2      | 0.75      | 9.2      | 0.95      | 10.8     | 1.20      | 11.8     | 1.20      |          |           |          |           |
| 62        | 9.0      | 0.65      | 9.9      | 0.85      | 11.4     | 1.15      | 12.4     | 1.15      |          |           |          |           |
| 60        | 9.5      | 0.60      | 10.4     | 0.80      | 11.8     | 1.10      | 12.7     | 1.10      |          |           |          |           |
| 57        | 10.2     | 0.52      | 11.1     | 0.75      | 12.4     | 1.05      | 13.2     | 1.00      |          |           |          |           |
| 55        | 10.7     | 0.48      | 11.5     | 0.70      | 12.8     | 1.00      | 13.5     | 0.95      |          |           |          |           |
| 52        | 11.3     | 0.40      | 12.1     | 0.65      | 13.3     | 0.95      | 13.9     | 0.88      |          |           |          |           |
| 50        | 11.8     | 0.37      | 12.5     | 0.60      | 13.6     | 0.90      | 14.1     | 0.84      |          |           |          |           |
| A(°)      | 20~82    |           | 15~82    |           | 30~82    |           | 45~82    |           | 60~82    |           | 75~82    |           |

| ジブオフセット   | 7°       |           | 15°      |           | 30°      |           | 45°      |           | 60°      |           | 75°      |           |
|-----------|----------|-----------|----------|-----------|----------|-----------|----------|-----------|----------|-----------|----------|-----------|
| ブーム角度 (°) | 作業半径 (m) | 定格総荷重 (t) | 作業半径 (m) | 定格総荷重 (t) | 作業半径 (m) | 定格総荷重 (t) | 作業半径 (m) | 定格総荷重 (t) | 作業半径 (m) | 定格総荷重 (t) | 作業半径 (m) | 定格総荷重 (t) |
| 82        | 4.8      | 0.70      | 6.5      | 0.70      | 9.6      | 0.70      | 12.1     | 0.68      | 13.7     | 0.60      | 14.5     | 0.55      |
| 80        | 5.5      | 0.70      | 7.3      | 0.70      | 10.3     | 0.70      | 12.6     | 0.68      | 14.2     | 0.59      | 14.8     | 0.55      |
| 78        | 6.3      | 0.70      | 8.0      | 0.70      | 10.9     | 0.70      | 13.2     | 0.68      | 14.6     | 0.58      | 15.1     | 0.55      |
| 74        | 7.7      | 0.70      | 9.4      | 0.70      | 12.2     | 0.70      | 14.3     | 0.64      | 15.5     | 0.57      |          |           |
| 72        | 8.4      | 0.63      | 10.1     | 0.70      | 12.8     | 0.70      | 14.8     | 0.63      | 15.8     | 0.56      |          |           |
| 70        | 9.1      | 0.53      | 10.7     | 0.62      | 13.4     | 0.70      | 15.2     | 0.61      | 16.2     | 0.56      |          |           |
| 67        | 10.2     | 0.43      | 11.7     | 0.53      | 14.2     | 0.69      | 15.9     | 0.60      | 16.7     | 0.55      |          |           |
| 65        | 10.8     | 0.35      | 12.3     | 0.48      | 14.7     | 0.68      | 16.3     | 0.59      | 17.0     | 0.55      |          |           |
| 62        | 11.8     | 0.30      | 13.2     | 0.43      | 15.5     | 0.64      | 17.0     | 0.58      |          |           |          |           |
| 60        | 12.4     | 0.27      | 13.8     | 0.40      | 16.0     | 0.62      | 17.3     | 0.57      |          |           |          |           |
| 57        |          |           |          |           | 16.7     | 0.59      | 17.8     | 0.55      |          |           |          |           |
| A(°)      | 35~82    |           | 30~82    |           | 45~82    |           | 60~82    |           | 75~82    |           |          |           |

| ジブオフセット   | 7°       |           | 15°      |           | 30°      |           | 45°      |           | 60°      |           | 75°      |           |
|-----------|----------|-----------|----------|-----------|----------|-----------|----------|-----------|----------|-----------|----------|-----------|
| ブーム角度 (°) | 作業半径 (m) | 定格総荷重 (t) | 作業半径 (m) | 定格総荷重 (t) | 作業半径 (m) | 定格総荷重 (t) | 作業半径 (m) | 定格総荷重 (t) | 作業半径 (m) | 定格総荷重 (t) | 作業半径 (m) | 定格総荷重 (t) |
| 82        | 5.5      | 0.65      | 7.5      | 0.65      | 11.1     | 0.40      | 13.9     | 0.30      | 15.9     | 0.27      | 16.8     | 0.27      |
| 80        | 6.3      | 0.65      | 8.3      | 0.65      | 11.8     | 0.40      | 14.5     | 0.30      | 16.4     | 0.27      | 17.2     | 0.27      |
| 78        | 7.1      | 0.65      | 9.1      | 0.65      | 12.5     | 0.40      | 15.1     | 0.30      | 16.8     | 0.27      |          |           |
| 74        | 8.7      | 0.60      | 10.6     | 0.56      | 13.9     | 0.38      | 16.3     | 0.30      | 17.7     | 0.27      |          |           |
| 72        | 9.5      | 0.50      | 11.4     | 0.53      | 14.5     | 0.37      | 16.8     | 0.30      | 18.1     | 0.27      |          |           |
| 70        | 10.3     | 0.40      | 12.1     | 0.50      | 15.2     | 0.35      | 17.3     | 0.30      | 18.5     | 0.27      |          |           |
| 67        | 11.4     | 0.33      | 13.2     | 0.44      | 16.1     | 0.34      | 18.1     | 0.29      | 19.0     | 0.27      |          |           |
| 65        | 12.2     | 0.29      | 13.9     | 0.40      | 16.7     | 0.33      | 18.5     | 0.28      |          |           |          |           |
| 62        | 13.2     | 0.24      | 14.9     | 0.35      | 17.5     | 0.31      | 19.2     | 0.28      |          |           |          |           |
| 60        | 13.9     | 0.20      | 15.5     | 0.32      | 18.0     | 0.30      | 19.6     | 0.27      |          |           |          |           |
| 57        |          |           |          |           | 18.8     | 0.28      | 20.1     | 0.27      |          |           |          |           |
| A(°)      | 45~82    |           | 40~82    |           | 35~82    |           | 45~82    |           | 60~82    |           | 75~82    |           |

A: ブーム角度の範囲 (無負荷時)

| ジブオフセット   | ※7°      |           | ※15°     |           | 30°      |           | 45°      |           | 60°      |           | 75°      |           |
|-----------|----------|-----------|----------|-----------|----------|-----------|----------|-----------|----------|-----------|----------|-----------|
| ブーム角度 (°) | 作業半径 (m) | 定格総荷重 (t) | 作業半径 (m) | 定格総荷重 (t) | 作業半径 (m) | 定格総荷重 (t) | 作業半径 (m) | 定格総荷重 (t) | 作業半径 (m) | 定格総荷重 (t) | 作業半径 (m) | 定格総荷重 (t) |
| 82        | 1.8      | 1.80      | 2.5      | 1.80      | 3.0      | 1.80      | 3.8      | 1.80      | 4.3      | 1.80      | 4.6      | 1.80      |
| 80        | 2.2      | 1.80      | 2.8      | 1.80      | 3.3      | 1.80      | 4.0      | 1.80      | 4.5      | 1.80      | 4.8      | 1.80      |
| 78        | 2.6      | 1.80      | 3.2      | 1.80      | 3.6      | 1.80      | 4.3      | 1.80      | 4.8      | 1.80      | 4.9      | 1.80      |
| 74        | 3.3      | 1.80      | 3.9      | 1.80      | 4.2      | 1.80      | 4.8      | 1.80      | 5.2      | 1.80      |          |           |
| 72        | 3.6      | 1.80      | 4.2      | 1.80      | 4.5      | 1.80      | 5.1      | 1.80      | 5.4      | 1.80      |          |           |
| 70        | 3.9      | 1.80      | 4.5      | 1.80      | 4.7      | 1.80      | 5.3      | 1.80      | 5.6      | 1.80      |          |           |
| 67        | 4.4      | 1.70      | 4.9      | 1.75      | 5.1      | 1.80      | 5.6      | 1.80      | 5.9      | 1.80      |          |           |
| 65        | 4.7      | 1.65      | 5.2      | 1.70      | 5.4      | 1.80      | 5.8      | 1.80      | 6.1      | 1.80      |          |           |
| 62        | 5.2      | 1.60      | 5.7      | 1.65      | 5.7      | 1.80      | 6.1      | 1.80      |          |           |          |           |
| 60        | 5.5      | 1.55      | 6.0      | 1.60      | 5.9      | 1.80      | 6.3      | 1.80      |          |           |          |           |
| 57        | 5.9      | 1.50      | 6.4      | 1.55      | 6.3      | 1.80      | 6.6      | 1.80      |          |           |          |           |
| 55        | 6.1      | 1.45      | 6.6      | 1.55      | 6.5      | 1.80      | 6.8      | 1.80      |          |           |          |           |
| 52        | 6.5      | 1.40      | 7.0      | 1.50      | 6.8      | 1.80      | 7.0      | 1.80      |          |           |          |           |
| 50        | 6.8      | 1.40      |          |           | 6.9      | 1.80      |          |           |          |           |          |           |
| A(°)      | 7~82     |           | 15~82    |           | 30~82    |           | 45~82    |           | 60~82    |           | 75~82    |           |

| ジブオフセット   | 7°       |           | 15°      |           | 30°      |           | 45°      |           | 60°      |           | 75°      |           |
|-----------|----------|-----------|----------|-----------|----------|-----------|----------|-----------|----------|-----------|----------|-----------|
| ブーム角度 (°) | 作業半径 (m) | 定格総荷重 (t) | 作業半径 (m) | 定格総荷重 (t) | 作業半径 (m) | 定格総荷重 (t) | 作業半径 (m) | 定格総荷重 (t) | 作業半径 (m) | 定格総荷重 (t) | 作業半径 (m) | 定格総荷重 (t) |
| 82        | 2.3      | 1.80      | 3.1      | 1.80      | 4.6      | 1.80      | 5.8      | 1.80      | 6.6      | 1.80      | 7.0      | 1.80      |
| 80        | 2.7      | 1.80      | 3.5      | 1.80      | 4.9      | 1.80      | 6.1      | 1.80      | 6.8      | 1.80      | 7.2      | 1.80      |
| 78        | 3.1      | 1.80      | 3.9      | 1.80      | 5.3      | 1.80      | 6.4      | 1.80      | 7.1      | 1.80      | 7.4      | 1.80      |
| 74        | 3.9      | 1.80      | 4.6      | 1.80      | 6.0      | 1.80      | 7.0      | 1.80      | 7.6      | 1.80      |          |           |
| 72        | 4.2      | 1.80      | 5.0      | 1.80      | 6.3      | 1.80      | 7.3      | 1.80      | 7.8      | 1.80      |          |           |
| 70        | 4.6      | 1.80      | 5.4      | 1.80      | 6.6      | 1.80      | 7.5      | 1.80      | 8.0      | 1.80      |          |           |
| 67        | 5.2      | 1.55      | 5.9      | 1.65      | 7.1      | 1.80      | 7.9      | 1.80      |          |           |          |           |
| 65        | 5.5      | 1.40      | 6.2      | 1.55      | 7.4      | 1.80      | 8.2      | 1.80      |          |           |          |           |
| 62        | 6.0      | 1.20      | 6.7      | 1.40      | 7.8      | 1.80      | 8.5      | 1.80      |          |           |          |           |
| 60        | 6.4      | 1.10      | 7.0      | 1.35      | 8.1      | 1.80      | 8.7      | 1.80      |          |           |          |           |
| 57        | 6.9      | 1.00      | 7.5      | 1.25      | 8.5      | 1.70      | 9.0      | 1.80      |          |           |          |           |
| 55        | 7.2      | 0.90      | 7.8      | 1.20      | 8.7      | 1.65      |          |           |          |           |          |           |
| 52        | 7.9      | 0.80      | 8.2      | 1.10      | 9.0      | 1.60      |          |           |          |           |          |           |
| 50        |          |           | 8.5      | 1.05      | 9.3      | 1.55      |          |           |          |           |          |           |
| 45        |          |           |          |           | 9.7      | 1.50      |          |           |          |           |          |           |
| A(°)      | 7~82     |           | 15~82    |           | 30~82    |           | 45~82    |           | 60~82    |           | 75~82    |           |

| ジブオフセット   | 7°       |           | 15°      |           | 30°      |           | 45°      |           | 60°      |           | 75°      |           |
|-----------|----------|-----------|----------|-----------|----------|-----------|----------|-----------|----------|-----------|----------|-----------|
| ブーム角度 (°) | 作業半径 (m) | 定格総荷重 (t) | 作業半径 (m) | 定格総荷重 (t) | 作業半径 (m) | 定格総荷重 (t) | 作業半径 (m) | 定格総荷重 (t) | 作業半径 (m) | 定格総荷重 (t) | 作業半径 (m) | 定格総荷重 (t) |
| 82        | 3.0      | 1.20      | 4.1      | 1.20      | 6.1      | 1.20      | 7.7      | 1.20      | 8.8      | 1.20      | 9.3      | 1.20      |
| 80        | 3.4      | 1.20      | 4.6      | 1.20      | 6.5      | 1.20      | 8.1      | 1.20      | 9.1      | 1.20      | 9.6      | 1.20      |
| 78        | 3.9      | 1.20      | 5.0      | 1.20      | 6.9      | 1.20      | 8.4      | 1.20      | 9.4      | 1.20      |          |           |
| 74        | 4.8      | 1.20      | 5.9      | 1.20      | 7.7      | 1.20      | 9.1      | 1.20      | 9.9      | 1.20      |          |           |
| 72        | 5.3      | 1.20      | 6.4      | 1.20      | 8.1      | 1.20      | 9.4      | 1.20      | 10.2     | 1.20      |          |           |
| 70        | 5.8      | 1.05      | 6.8      | 1.15      | 8.5      | 1.20      | 9.7      | 1.20      | 10.4     | 1.20      |          |           |
| 67        | 6.4      | 0.90      | 7.4      | 1.05      | 9.0      | 1.20      | 10.2     | 1.20      | 10.7     | 1.20      |          |           |
| 65        | 6.8      | 0.78      | 7.8      | 0.97      | 9.4      | 1.20      | 10.5     | 1.20      | 10.9     | 1.20      |          |           |
| 62        | 7.5      | 0.68      | 8.4      | 0.85      | 9.9      | 1.15      | 10.8     | 1.20      | 11.2     | 1.20      |          |           |
| 60        | 7.9      | 0.63      | 8.8      | 0.80      | 10.2     | 1.10      | 11.1     | 1.20      |          |           |          |           |
| 57        | 8.4      | 0.53      | 9.3      | 0.72      | 10.6     | 1.05      | 11.4     | 1.20      |          |           |          |           |
| 55        | 8.8      | 0.48      | 9.7      | 0.68      | 10.9     | 1.00      | 11.6     | 1.20      |          |           |          |           |
| 52        | 9.4      | 0.42      | 10.1     | 0.63      | 11.3     | 0.97      | 11.9     | 1.20      |          |           |          |           |
| 50        | 9.7      | 0.38      | 10.5     | 0.60      | 11.5     | 0.94      | 12.0     | 1.20      |          |           |          |           |
| A(°)      | 7~82     |           | 15~82    |           | 30~82    |           | 45~82    |           | 60~82    |           | 75~82    |           |

| ジブオフセット   | 7°       |           | 15°      |           | 30°      |           | 45°      |           | 60°      |           | 75°      |           |
|-----------|----------|-----------|----------|-----------|----------|-----------|----------|-----------|----------|-----------|----------|-----------|
| ブーム角度 (°) | 作業半径 (m) | 定格総荷重 (t) | 作業半径 (m) | 定格総荷重 (t) | 作業半径 (m) | 定格総荷重 (t) | 作業半径 (m) | 定格総荷重 (t) | 作業半径 (m) | 定格総荷重 (t) | 作業半径 (m) | 定格総荷重 (t) |
| 82        | 4.3      | 0.70      | 6.0      | 0.70      | 9.1      | 0.70      | 11.6     | 0.68      | 13.2     | 0.55      | 14.0     | 0.55      |
| 80        | 4.9      | 0.70      | 6.7      | 0.70      | 9.7      | 0.70      | 12.0     | 0.68      | 13.6     | 0.55      | 14.3     | 0.55      |
| 78        | 5.6      | 0.70      | 7.3      | 0.70      | 10.2     | 0.70      | 12.5     | 0.66      | 13.9     | 0.55      | 14.5     | 0.55      |
| 74        | 6.8      | 0.70      | 8.4      | 0.70      | 11.2     | 0.70      | 13.3     | 0.64      | 14.5     | 0.55      |          |           |
| 72        | 7.4      | 0.65      | 9.0      | 0.70      | 11.7     | 0.70      | 13.7     | 0.63      | 14.8     | 0.55      |          |           |
| 70        | 8.0      | 0.55      | 9.6      | 0.65      | 12.2     | 0.70      | 14.1     | 0.62      | 15.1     | 0.55      |          |           |
| 67        | 8.9      | 0.45      | 10.4     | 0.55      | 12.9     | 0.70      | 14.6     | 0.61      |          |           |          |           |
| 65        | 9.4      | 0.40      | 10.9     | 0.50      | 13.3     | 0.69      | 15.0     | 0.60      |          |           |          |           |
| 62        | 10.3     | 0.33      | 11.7     | 0.43      | 14.0     | 0.65      | 15.4     | 0.58      |          |           |          |           |
| 60        | 10.8     | 0.27      | 12.2     | 0.39      | 14.4     | 0.63      | 15.7     | 0.57      |          |           |          |           |
| 57        |          |           | 12.9     | 0.35      | 14.9     | 0.60      | 16.1     | 0.56      |          |           |          |           |
| A(°)      | 35~82    |           | 15~82    |           | 30~82    |           | 45~82    |           | 60~82    |           | 75~82    |           |

| ジブオフセット   | 7°       |           | 15°      |           | 30°      |           | 45°      |           | 60°      |           | 75°      |           |
|-----------|----------|-----------|----------|-----------|----------|-----------|----------|-----------|----------|-----------|----------|-----------|
| ブーム角度 (°) | 作業半径 (m) | 定格総荷重 (t) | 作業半径 (m) | 定格総荷重 (t) | 作業半径 (m) | 定格総荷重 (t) | 作業半径 (m) | 定格総荷重 (t) | 作業半径 (m) | 定格総荷重 (t) | 作業半径 (m) | 定格総荷重 (t) |
| 82        | 5.0      | 0.65      | 7.0      | 0.65      | 10.6     | 0.40      | 13.4     | 0.30      | 15.4     | 0.27      | 16.3     | 0.27      |
| 80        | 5.7      | 0.65      | 7.7      | 0.65      | 11.2     | 0.40      | 13.9     | 0.30      | 15.8     | 0.27      | 16.5     | 0.27      |
| 78        | 6.4      | 0.65      | 8.4      | 0.65      | 11.8     | 0.40      | 14.4     | 0.30      | 16.1     | 0.27      |          |           |
| 74        | 7.8      | 0.55      | 9.7      | 0.56      | 12.9     | 0.38      | 15.4     | 0.30      | 16.8     | 0.27      |          |           |
| 72        | 8.5      | 0.50      | 10.4     | 0.53      | 13.5     | 0.37      | 15.8     | 0.29      | 17.1     | 0.27      |          |           |
| 70        | 9.1      | 0.43      | 11.0     | 0.50      | 14.0     | 0.36      | 16.2     | 0.29      | 17.4     | 0.27      |          |           |
| 67        | 10.1     | 0.35      | 11.9     | 0.45      | 14.8     | 0.34      | 16.8     | 0.28      | 17.7     | 0.27      |          |           |
| 65        | 10.8     | 0.30      | 12.5     | 0.40      | 15.3     | 0.33      | 17.1     | 0.28      | 18.0     | 0.27      |          |           |
| 62        | 11.7     | 0.25      | 13.4     | 0.33      | 16.0     | 0.32      | 17.6     | 0.27      |          |           |          |           |
| 60        |          |           | 13.9     | 0.30      | 16.4     | 0.31      | 17.9     | 0.27      |          |           |          |           |
| 57        |          |           |          |           | 17.0     | 0.30      |          |           |          |           |          |           |
| A(°)      | 45~82    |           | 35~82    |           | 30~82    |           | 45~82    |           | 60~82    |           | 75~82    |           |

| 15.0mブーム+4.1mジブ |          |           |          |           |          |           |          |           |          |           |          |           |
|-----------------|----------|-----------|----------|-----------|----------|-----------|----------|-----------|----------|-----------|----------|-----------|
| ジブオフセット         | ※7°      |           | ※15°     |           | 30°      |           | 45°      |           | 60°      |           | 75°      |           |
| ブーム角度 (°)       | 作業半径 (m) | 定格総荷重 (t) | 作業半径 (m) | 定格総荷重 (t) | 作業半径 (m) | 定格総荷重 (t) | 作業半径 (m) | 定格総荷重 (t) | 作業半径 (m) | 定格総荷重 (t) | 作業半径 (m) | 定格総荷重 (t) |
| 82              | 3.3      | 1.80      | 4.0      | 1.80      | 4.6      | 1.80      | 5.4      | 1.80      | 5.9      | 1.80      | 6.1      | 1.80      |
| 80              | 4.0      | 1.80      | 4.7      | 1.80      | 5.3      | 1.80      | 6.0      | 1.80      | 6.4      | 1.80      | 6.6      | 1.80      |
| 78              | 4.8      | 1.80      | 5.3      | 1.80      | 5.9      | 1.80      | 6.6      | 1.80      | 7.0      | 1.80      | 7.1      | 1.80      |
| 74              | 6.1      | 1.80      | 6.7      | 1.80      | 7.1      | 1.80      | 7.7      | 1.80      | 8.1      | 1.80      |          |           |
| 72              | 6.8      | 1.80      | 7.4      | 1.80      | 7.7      | 1.80      | 8.2      | 1.80      | 8.6      | 1.70      |          |           |
| 70              | 7.5      | 1.75      | 8.0      | 1.75      | 8.2      | 1.80      | 8.8      | 1.70      | 9.1      | 1.60      |          |           |
| 67              | 8.4      | 1.65      | 8.9      | 1.55      | 9.1      | 1.60      | 9.6      | 1.50      | 9.8      | 1.40      |          |           |
| 65              | 9.0      | 1.50      | 9.5      | 1.40      | 9.6      | 1.40      | 10.1     | 1.35      | 10.3     | 1.25      |          |           |
| 62              | 9.9      | 1.25      | 10.4     | 1.20      | 10.4     | 1.20      | 10.8     | 1.15      | 11.0     | 1.10      |          |           |
| 60              |          |           | 10.9     | 1.05      | 10.9     | 1.05      | 11.3     | 1.00      |          |           |          |           |
| 57              |          |           |          |           |          |           | 12.0     | 0.80      |          |           |          |           |
| A(°)            | 45~82    |           |          |           |          |           | 60~82    |           |          | 75~82     |          |           |

| 15.0mブーム+6.5mジブ |          |           |          |           |          |           |          |           |          |           |          |           |
|-----------------|----------|-----------|----------|-----------|----------|-----------|----------|-----------|----------|-----------|----------|-----------|
| ジブオフセット         | 7°       |           | 15°      |           | 30°      |           | 45°      |           | 60°      |           | 75°      |           |
| ブーム角度 (°)       | 作業半径 (m) | 定格総荷重 (t) | 作業半径 (m) | 定格総荷重 (t) | 作業半径 (m) | 定格総荷重 (t) | 作業半径 (m) | 定格総荷重 (t) | 作業半径 (m) | 定格総荷重 (t) | 作業半径 (m) | 定格総荷重 (t) |
| 82              | 4.0      | 1.80      | 4.8      | 1.80      | 6.3      | 1.80      | 7.5      | 1.80      | 8.3      | 1.80      | 8.6      | 1.75      |
| 80              | 4.7      | 1.80      | 5.6      | 1.80      | 7.0      | 1.80      | 8.1      | 1.80      | 8.8      | 1.80      | 9.1      | 1.75      |
| 78              | 5.5      | 1.80      | 6.3      | 1.80      | 7.7      | 1.80      | 8.8      | 1.80      | 9.4      | 1.70      | 9.6      | 1.70      |
| 74              | 6.9      | 1.80      | 7.7      | 1.80      | 9.0      | 1.75      | 10.0     | 1.50      | 10.5     | 1.40      |          |           |
| 72              | 7.6      | 1.80      | 8.3      | 1.80      | 9.6      | 1.55      | 10.6     | 1.35      | 11.1     | 1.25      |          |           |
| 70              | 8.2      | 1.70      | 9.0      | 1.65      | 10.3     | 1.35      | 11.2     | 1.20      | 11.6     | 1.15      |          |           |
| 67              | 9.2      | 1.45      | 10.0     | 1.35      | 11.2     | 1.15      | 12.0     | 1.05      | 12.4     | 1.00      |          |           |
| 65              | 9.9      | 1.30      | 10.6     | 1.20      | 11.8     | 1.05      | 12.5     | 0.95      | 12.8     | 0.90      |          |           |
| 62              | 10.8     | 1.10      | 11.5     | 1.00      | 12.6     | 0.85      | 13.3     | 0.75      |          |           |          |           |
| 60              | 11.5     | 0.95      | 12.1     | 0.85      | 13.2     | 0.70      | 13.8     | 0.65      |          |           |          |           |
| 57              |          |           | 13.0     | 0.65      | 14.0     | 0.50      |          |           |          |           |          |           |
| A(°)            | 50~82    |           |          | 45~82     |          |           |          | 60~82     |          |           | 75~82    |           |

| 15.0mブーム+8.9mジブ |          |           |          |           |          |           |          |           |          |           |          |           |
|-----------------|----------|-----------|----------|-----------|----------|-----------|----------|-----------|----------|-----------|----------|-----------|
| ジブオフセット         | 7°       |           | 15°      |           | 30°      |           | 45°      |           | 60°      |           | 75°      |           |
| ブーム角度 (°)       | 作業半径 (m) | 定格総荷重 (t) | 作業半径 (m) | 定格総荷重 (t) | 作業半径 (m) | 定格総荷重 (t) | 作業半径 (m) | 定格総荷重 (t) | 作業半径 (m) | 定格総荷重 (t) | 作業半径 (m) | 定格総荷重 (t) |
| 82              | 4.7      | 1.20      | 5.9      | 1.20      | 7.9      | 1.20      | 9.5      | 1.20      | 10.5     | 1.20      | 11.0     | 1.15      |
| 80              | 5.5      | 1.20      | 6.7      | 1.20      | 8.7      | 1.20      | 10.2     | 1.20      | 11.2     | 1.20      | 11.5     | 1.15      |
| 78              | 6.3      | 1.20      | 7.4      | 1.20      | 9.4      | 1.20      | 10.8     | 1.20      | 11.8     | 1.20      | 12.0     | 1.15      |
| 74              | 7.8      | 1.20      | 9.0      | 1.20      | 10.8     | 1.20      | 12.2     | 1.20      | 12.9     | 1.05      |          |           |
| 72              | 8.6      | 1.10      | 9.7      | 1.20      | 11.5     | 1.20      | 12.8     | 1.05      | 13.5     | 0.95      |          |           |
| 70              | 9.4      | 1.00      | 10.5     | 1.10      | 12.2     | 1.10      | 13.4     | 0.95      | 14.0     | 0.90      |          |           |
| 67              | 10.5     | 0.80      | 11.5     | 1.00      | 13.2     | 0.90      | 14.3     | 0.80      | 14.8     | 0.75      |          |           |
| 65              | 11.2     | 0.70      | 12.2     | 0.90      | 13.8     | 0.80      | 14.9     | 0.70      | 15.3     | 0.65      |          |           |
| 62              | 12.3     | 0.60      | 13.2     | 0.80      | 14.8     | 0.60      | 15.7     | 0.53      | 16.0     | 0.50      |          |           |
| 60              | 12.9     | 0.55      | 13.9     | 0.70      | 15.3     | 0.50      | 16.2     | 0.43      |          |           |          |           |
| 57              |          |           |          |           | 16.2     | 0.35      | 16.9     | 0.30      |          |           |          |           |
| A(°)            | 45~82    |           |          |           | 60~82    |           |          |           | 75~82    |           |          |           |

| 15.0mブーム+13.6mジブ |          |           |          |           |          |           |          |           |          |           |          |           |       |  |
|------------------|----------|-----------|----------|-----------|----------|-----------|----------|-----------|----------|-----------|----------|-----------|-------|--|
| ジブオフセット          | 7°       |           | 15°      |           | 30°      |           | 45°      |           | 60°      |           | 75°      |           |       |  |
| ブーム角度 (°)        | 作業半径 (m) | 定格総荷重 (t) | 作業半径 (m) | 定格総荷重 (t) | 作業半径 (m) | 定格総荷重 (t) | 作業半径 (m) | 定格総荷重 (t) | 作業半径 (m) | 定格総荷重 (t) | 作業半径 (m) | 定格総荷重 (t) |       |  |
| 82               | 6.1      | 0.70      | 7.9      | 0.70      | 11.0     | 0.70      | 13.4     | 0.65      | 14.9     | 0.58      | 15.6     | 0.55      |       |  |
| 80               | 7.0      | 0.70      | 8.8      | 0.70      | 11.9     | 0.70      | 14.2     | 0.65      | 15.6     | 0.58      | 16.1     | 0.55      |       |  |
| 78               | 8.0      | 0.70      | 9.7      | 0.70      | 12.7     | 0.70      | 14.9     | 0.65      | 16.3     | 0.58      | 16.7     | 0.55      |       |  |
| 74               | 9.9      | 0.70      | 11.6     | 0.70      | 14.4     | 0.70      | 16.4     | 0.61      | 17.5     | 0.57      |          |           |       |  |
| 72               | 10.8     | 0.60      | 12.4     | 0.70      | 15.2     | 0.70      | 17.1     | 0.59      | 18.1     | 0.56      |          |           |       |  |
| 70               | 11.7     | 0.50      | 13.3     | 0.60      | 16.0     | 0.70      | 17.8     | 0.56      | 18.7     | 0.55      |          |           |       |  |
| 67               | 13.0     | 0.45      | 14.6     | 0.52      | 17.1     | 0.65      | 18.8     | 0.48      | 19.5     | 0.43      |          |           |       |  |
| 65               | 13.9     | 0.35      | 15.4     | 0.48      | 17.8     | 0.50      | 19.4     | 0.40      | 20.0     | 0.30      |          |           |       |  |
| 62               |          |           |          |           | 18.9     | 0.35      |          |           |          |           |          |           |       |  |
| 60               |          |           |          |           | 19.6     | 0.25      |          |           |          |           |          |           |       |  |
| A(°)             | 50~82    |           |          | 52~82     |          |           |          | 57~82     |          |           | 60~82    |           | 75~82 |  |

| 15.0mブーム+15.9mジブ |          |           |          |           |          |           |          |           |          |           |          |           |  |
|------------------|----------|-----------|----------|-----------|----------|-----------|----------|-----------|----------|-----------|----------|-----------|--|
| ジブオフセット          | 7°       |           | 15°      |           | 30°      |           | 45°      |           | 60°      |           | 75°      |           |  |
| ブーム角度 (°)        | 作業半径 (m) | 定格総荷重 (t) | 作業半径 (m) | 定格総荷重 (t) | 作業半径 (m) | 定格総荷重 (t) | 作業半径 (m) | 定格総荷重 (t) | 作業半径 (m) | 定格総荷重 (t) | 作業半径 (m) | 定格総荷重 (t) |  |
| 82               | 6.8      | 0.65      | 8.8      | 0.65      | 12.3     | 0.40      | 15.1     | 0.30      | 17.0     | 0.27      | 17.9     | 0.27      |  |
| 80               | 7.8      | 0.65      | 9.9      | 0.65      | 13.3     | 0.40      | 16.0     | 0.30      | 17.7     | 0.27      | 18.4     | 0.27      |  |
| 78               | 8.9      | 0.65      | 10.9     | 0.60      | 14.2     | 0.40      | 16.8     | 0.30      | 18.4     | 0.27      | 19.0     | 0.27      |  |
| 74               | 10.9     | 0.55      | 12.8     | 0.52      | 16.0     | 0.37      | 18.3     | 0.30      | 19.7     | 0.27      |          |           |  |
| 72               | 11.9     | 0.45      | 13.8     | 0.49      | 16.8     | 0.36      | 19.1     | 0.29      | 20.3     | 0.27      |          |           |  |
| 70               | 12.8     | 0.40      | 14.7     | 0.46      | 17.7     | 0.35      | 19.8     | 0.28      | 20.9     | 0.27      |          |           |  |
| 67               | 14.3     | 0.33      | 16.1     | 0.42      | 18.9     | 0.33      | 20.8     | 0.27      | 21.7     | 0.27      |          |           |  |
| 65               | 15.2     | 0.28      | 17.0     | 0.38      | 19.7     | 0.32      | 21.5     | 0.26      | 22.3     | 0.27      |          |           |  |
| 62               | 16.6     | 0.22      | 18.2     | 0.34      | 20.8     | 0.30      | 22.4     | 0.25      | 23.0     | 0.24      |          |           |  |
| 60               |          |           | 19.1     | 0.31      | 21.5     | 0.28      | 23.0     | 0.20      |          |           |          |           |  |
| A(°)             | 52~82    |           |          |           | 55~82    |           |          |           | 60~82    |           |          | 75~82     |  |

A: ブーム角度の範囲 (無負荷時)

| ジブオフセット   | ※7°      |           | ※15°     |           | 30°      |           | 45°      |           | 60°      |           | 75°      |           |
|-----------|----------|-----------|----------|-----------|----------|-----------|----------|-----------|----------|-----------|----------|-----------|
| ブーム角度 (°) | 作業半径 (m) | 定格総荷重 (t) | 作業半径 (m) | 定格総荷重 (t) | 作業半径 (m) | 定格総荷重 (t) | 作業半径 (m) | 定格総荷重 (t) | 作業半径 (m) | 定格総荷重 (t) | 作業半径 (m) | 定格総荷重 (t) |
| 82        | 2.8      | 1.80      | 3.4      | 1.80      | 4.0      | 1.80      | 4.8      | 1.80      | 5.3      | 1.80      | 5.5      | 1.80      |
| 80        | 3.4      | 1.80      | 3.9      | 1.80      | 4.5      | 1.80      | 5.3      | 1.80      | 5.7      | 1.80      | 5.9      | 1.80      |
| 78        | 3.9      | 1.80      | 4.6      | 1.80      | 5.1      | 1.80      | 5.7      | 1.80      | 6.2      | 1.80      |          |           |
| 74        | 5.1      | 1.80      | 5.7      | 1.80      | 6.0      | 1.80      | 6.7      | 1.80      | 7.0      | 1.80      |          |           |
| 72        | 5.6      | 1.80      | 6.1      | 1.80      | 6.5      | 1.80      | 7.1      | 1.80      | 7.4      | 1.80      |          |           |
| 70        | 6.1      | 1.80      | 6.7      | 1.80      | 7.0      | 1.80      | 7.6      | 1.80      | 7.9      | 1.80      |          |           |
| 67        | 6.9      | 1.65      | 7.5      | 1.80      | 7.7      | 1.80      | 8.2      | 1.80      | 8.4      | 1.75      |          |           |
| 65        | 7.5      | 1.60      | 8.0      | 1.70      | 8.1      | 1.80      | 8.6      | 1.70      | 8.8      | 1.70      |          |           |
| 62        | 8.2      | 1.55      | 8.7      | 1.60      | 8.8      | 1.65      | 9.2      | 1.50      |          |           |          |           |
| 60        | 8.7      | 1.45      | 9.2      | 1.50      | 9.2      | 1.55      | 9.6      | 1.40      |          |           |          |           |
| 57        | 9.4      | 1.30      | 9.9      | 1.30      | 9.8      | 1.35      | 10.1     | 1.25      |          |           |          |           |
| 55        | 9.8      | 1.15      | 10.3     | 1.20      | 10.2     | 1.25      | 10.5     | 1.15      |          |           |          |           |
| 52        | 10.5     | 1.05      | 11.0     | 1.05      | 10.7     | 1.10      | 11.0     | 1.05      |          |           |          |           |
| 50        | 10.9     | 0.95      |          |           | 11.1     | 1.00      |          |           |          |           |          |           |
| 45        |          |           |          |           | 11.9     | 0.80      |          |           |          |           |          |           |
| A(°)      | 30~82    |           | 25~82    |           | 30~82    |           | 45~82    |           | 60~82    |           | 75~82    |           |

| ジブオフセット   | 7°       |           | 15°      |           | 30°      |           | 45°      |           | 60°      |           | 75°      |           |
|-----------|----------|-----------|----------|-----------|----------|-----------|----------|-----------|----------|-----------|----------|-----------|
| ブーム角度 (°) | 作業半径 (m) | 定格総荷重 (t) | 作業半径 (m) | 定格総荷重 (t) | 作業半径 (m) | 定格総荷重 (t) | 作業半径 (m) | 定格総荷重 (t) | 作業半径 (m) | 定格総荷重 (t) | 作業半径 (m) | 定格総荷重 (t) |
| 82        | 3.3      | 1.80      | 4.2      | 1.80      | 5.6      | 1.80      | 6.8      | 1.80      | 7.6      | 1.80      | 8.0      | 1.80      |
| 80        | 4.0      | 1.80      | 4.8      | 1.80      | 6.2      | 1.80      | 7.3      | 1.80      | 8.1      | 1.80      | 8.4      | 1.80      |
| 78        | 4.6      | 1.80      | 5.4      | 1.80      | 6.8      | 1.80      | 7.9      | 1.80      | 8.6      | 1.80      | 8.8      | 1.80      |
| 74        | 5.8      | 1.80      | 6.6      | 1.80      | 7.9      | 1.80      | 8.9      | 1.80      | 9.5      | 1.70      |          |           |
| 72        | 6.4      | 1.80      | 7.1      | 1.80      | 8.4      | 1.80      | 9.4      | 1.70      | 9.9      | 1.55      |          |           |
| 70        | 6.9      | 1.75      | 7.7      | 1.80      | 9.0      | 1.75      | 9.9      | 1.55      | 10.3     | 1.45      |          |           |
| 67        | 7.8      | 1.45      | 8.5      | 1.80      | 9.7      | 1.55      | 10.5     | 1.35      | 10.9     | 1.30      |          |           |
| 65        | 8.3      | 1.35      | 9.1      | 1.55      | 10.2     | 1.40      | 11.0     | 1.25      | 11.3     | 1.20      |          |           |
| 62        | 9.2      | 1.20      | 9.9      | 1.35      | 10.9     | 1.20      | 11.6     | 1.10      | 11.9     | 1.05      |          |           |
| 60        | 9.7      | 1.05      | 10.4     | 1.25      | 11.4     | 1.10      | 12.0     | 1.05      |          |           |          |           |
| 57        | 10.4     | 0.93      | 11.1     | 1.10      | 12.1     | 1.00      | 12.6     | 0.90      |          |           |          |           |
| 55        | 10.9     | 0.85      | 11.6     | 1.00      | 12.5     | 0.90      | 13.0     | 0.80      |          |           |          |           |
| 52        | 11.6     | 0.78      | 12.2     | 0.88      | 13.1     | 0.75      | 13.5     | 0.70      |          |           |          |           |
| 50        | 12.1     | 0.73      | 12.7     | 0.78      | 13.5     | 0.65      | 13.8     | 0.60      |          |           |          |           |
| 45        | 13.2     | 0.63      |          |           |          |           |          |           |          |           |          |           |
| A(°)      | 35~82    |           | 30~82    |           | 45~82    |           | 60~82    |           | 75~82    |           |          |           |

| ジブオフセット   | 7°       |           | 15°      |           | 30°      |           | 45°      |           | 60°      |           | 75°      |           |
|-----------|----------|-----------|----------|-----------|----------|-----------|----------|-----------|----------|-----------|----------|-----------|
| ブーム角度 (°) | 作業半径 (m) | 定格総荷重 (t) | 作業半径 (m) | 定格総荷重 (t) | 作業半径 (m) | 定格総荷重 (t) | 作業半径 (m) | 定格総荷重 (t) | 作業半径 (m) | 定格総荷重 (t) | 作業半径 (m) | 定格総荷重 (t) |
| 82        | 4.0      | 1.20      | 5.2      | 1.20      | 7.2      | 1.20      | 8.8      | 1.20      | 9.9      | 1.20      | 10.3     | 1.20      |
| 80        | 4.7      | 1.20      | 5.9      | 1.20      | 7.8      | 1.20      | 9.4      | 1.20      | 10.4     | 1.20      | 10.8     | 1.20      |
| 78        | 5.4      | 1.20      | 6.5      | 1.20      | 8.5      | 1.20      | 9.9      | 1.20      | 10.9     | 1.20      | 11.2     | 1.20      |
| 74        | 6.8      | 1.20      | 7.9      | 1.20      | 9.7      | 1.20      | 11.0     | 1.20      | 11.8     | 1.20      |          |           |
| 72        | 7.4      | 1.15      | 8.5      | 1.20      | 10.3     | 1.20      | 11.6     | 1.20      | 12.3     | 1.20      |          |           |
| 70        | 8.1      | 1.00      | 9.1      | 1.15      | 10.9     | 1.20      | 12.1     | 1.20      | 12.7     | 1.10      |          |           |
| 67        | 9.0      | 0.85      | 10.1     | 1.00      | 11.7     | 1.15      | 12.8     | 1.05      | 13.4     | 1.00      |          |           |
| 65        | 9.7      | 0.75      | 10.7     | 0.93      | 12.3     | 1.10      | 13.3     | 0.98      | 13.8     | 0.95      |          |           |
| 62        | 10.6     | 0.65      | 11.5     | 0.85      | 13.0     | 1.00      | 14.0     | 0.85      |          |           |          |           |
| 60        | 11.2     | 0.60      | 12.1     | 0.80      | 13.5     | 0.90      | 14.4     | 0.77      |          |           |          |           |
| 57        | 12.0     | 0.50      | 12.9     | 0.70      | 14.3     | 0.75      | 15.0     | 0.65      |          |           |          |           |
| 55        | 12.6     | 0.45      | 13.4     | 0.68      | 14.7     | 0.65      | 15.4     | 0.58      |          |           |          |           |
| 52        | 13.4     | 0.40      | 14.2     | 0.63      | 15.4     | 0.55      | 15.9     | 0.47      |          |           |          |           |
| 50        | 13.9     | 0.37      | 14.7     | 0.55      | 15.8     | 0.45      | 16.2     | 0.40      |          |           |          |           |
| A(°)      | 35~82    |           | 30~82    |           | 45~82    |           | 60~82    |           | 75~82    |           |          |           |

| ジブオフセット   | 7°       |           | 15°      |           | 30°      |           | 45°      |           | 60°      |           | 75°      |           |
|-----------|----------|-----------|----------|-----------|----------|-----------|----------|-----------|----------|-----------|----------|-----------|
| ブーム角度 (°) | 作業半径 (m) | 定格総荷重 (t) | 作業半径 (m) | 定格総荷重 (t) | 作業半径 (m) | 定格総荷重 (t) | 作業半径 (m) | 定格総荷重 (t) | 作業半径 (m) | 定格総荷重 (t) | 作業半径 (m) | 定格総荷重 (t) |
| 82        | 5.4      | 0.70      | 7.2      | 0.70      | 10.2     | 0.70      | 12.7     | 0.70      | 14.3     | 0.58      | 15.0     | 0.55      |
| 80        | 6.2      | 0.70      | 8.0      | 0.70      | 11.0     | 0.70      | 13.4     | 0.69      | 14.8     | 0.58      | 15.5     | 0.55      |
| 78        | 7.1      | 0.70      | 8.8      | 0.70      | 11.8     | 0.70      | 14.0     | 0.67      | 15.4     | 0.58      |          |           |
| 74        | 8.7      | 0.70      | 10.4     | 0.70      | 13.2     | 0.70      | 15.3     | 0.65      | 16.4     | 0.57      |          |           |
| 72        | 9.5      | 0.65      | 11.2     | 0.70      | 13.9     | 0.70      | 15.9     | 0.63      | 16.9     | 0.57      |          |           |
| 70        | 10.3     | 0.55      | 12.0     | 0.60      | 14.6     | 0.70      | 16.5     | 0.61      | 17.4     | 0.56      |          |           |
| 67        | 11.5     | 0.45      | 13.1     | 0.55      | 15.6     | 0.70      | 17.3     | 0.59      | 18.0     | 0.55      |          |           |
| 65        | 12.3     | 0.39      | 13.8     | 0.50      | 16.2     | 0.68      | 17.8     | 0.58      | 18.5     | 0.53      |          |           |
| 62        | 13.4     | 0.33      | 14.9     | 0.45      | 17.1     | 0.62      | 18.6     | 0.50      | 19.0     | 0.50      |          |           |
| 60        | 14.1     | 0.29      | 15.5     | 0.42      | 17.7     | 0.58      | 19.0     | 0.45      |          |           |          |           |
| 57        | 15.2     | 0.24      |          |           |          |           | 19.7     | 0.30      |          |           |          |           |
| A(°)      | 40~82    |           | 35~82    |           | 45~82    |           | 60~82    |           | 75~82    |           |          |           |

| ジブオフセット   | 7°       |           | 15°      |           | 30°      |           | 45°      |           | 60°      |           | 75°      |           |
|-----------|----------|-----------|----------|-----------|----------|-----------|----------|-----------|----------|-----------|----------|-----------|
| ブーム角度 (°) | 作業半径 (m) | 定格総荷重 (t) | 作業半径 (m) | 定格総荷重 (t) | 作業半径 (m) | 定格総荷重 (t) | 作業半径 (m) | 定格総荷重 (t) | 作業半径 (m) | 定格総荷重 (t) | 作業半径 (m) | 定格総荷重 (t) |
| 82        | 6.1      | 0.65      | 8.1      | 0.65      | 11.6     | 0.40      | 14.5     | 0.30      | 16.4     | 0.27      | 17.3     | 0.27      |
| 80        | 7.0      | 0.65      | 9.0      | 0.65      | 12.5     | 0.40      | 15.2     | 0.30      | 17.0     | 0.27      | 17.7     | 0.27      |
| 78        | 7.9      | 0.65      | 9.9      | 0.60      | 13.3     | 0.40      | 15.9     | 0.30      | 17.6     | 0.27      | 18.2     | 0.27      |
| 74        | 9.8      | 0.60      | 11.7     | 0.53      | 14.9     | 0.38      | 17.3     | 0.30      | 18.7     | 0.27      |          |           |
| 72        | 10.6     | 0.48      | 12.5     | 0.51      | 15.6     | 0.37      | 17.9     | 0.29      | 19.2     | 0.27      |          |           |
| 70        | 11.5     | 0.42      | 13.4     | 0.48      | 16.4     | 0.35      | 18.5     | 0.28      | 19.7     | 0.27      |          |           |
| 67        | 12.8     | 0.32      | 14.6     | 0.42      | 17.4     | 0.33      | 19.4     | 0.28      | 20.3     | 0.27      |          |           |
| 65        | 13.6     | 0.27      | 15.4     | 0.38      | 18.1     | 0.32      | 20.0     | 0.27      | 20.8     | 0.27      |          |           |
| 62        | 14.8     | 0.20      | 16.5     | 0.34      | 19.1     | 0.30      | 20.8     | 0.26      |          |           |          |           |
| 60        |          |           | 17.2     | 0.32      | 19.7     | 0.29      | 21.3     | 0.25      |          |           |          |           |
| 57        |          |           |          |           |          |           | 21.9     | 0.25      |          |           |          |           |
| A(°)      |          |           | 45~82    |           | 50~82    |           | 60~82    |           | 75~82    |           |          |           |

| ジブオフセット   | ※7°      |           | ※15°     |           | 30°      |           | 45°      |           | 60°      |           | 75°      |           |
|-----------|----------|-----------|----------|-----------|----------|-----------|----------|-----------|----------|-----------|----------|-----------|
| ブーム角度 (°) | 作業半径 (m) | 定格総荷重 (t) | 作業半径 (m) | 定格総荷重 (t) | 作業半径 (m) | 定格総荷重 (t) | 作業半径 (m) | 定格総荷重 (t) | 作業半径 (m) | 定格総荷重 (t) | 作業半径 (m) | 定格総荷重 (t) |
| 82        | 2.3      | 1.80      | 2.9      | 1.80      | 3.5      | 1.80      | 4.2      | 1.80      | 4.8      | 1.80      | 5.0      | 1.80      |
| 80        | 2.8      | 1.80      | 3.4      | 1.80      | 3.9      | 1.80      | 4.6      | 1.80      | 5.1      | 1.80      | 5.3      | 1.80      |
| 78        | 3.2      | 1.80      | 3.9      | 1.80      | 4.3      | 1.80      | 5.0      | 1.80      | 5.4      | 1.80      | 5.6      | 1.80      |
| 74        | 4.1      | 1.80      | 4.7      | 1.80      | 5.1      | 1.80      | 5.7      | 1.80      | 6.1      | 1.80      |          |           |
| 72        | 4.6      | 1.80      | 5.2      | 1.80      | 5.5      | 1.80      | 6.1      | 1.80      | 6.4      | 1.80      |          |           |
| 70        | 5.0      | 1.80      | 5.6      | 1.80      | 5.8      | 1.80      | 6.4      | 1.80      | 6.7      | 1.80      |          |           |
| 67        | 5.6      | 1.70      | 6.2      | 1.75      | 6.4      | 1.80      | 6.9      | 1.80      | 7.1      | 1.80      |          |           |
| 65        | 6.1      | 1.65      | 6.6      | 1.70      | 6.7      | 1.80      | 7.2      | 1.80      |          |           |          |           |
| 62        | 6.7      | 1.60      | 7.2      | 1.65      | 7.2      | 1.80      | 7.7      | 1.80      |          |           |          |           |
| 60        | 7.1      | 1.55      | 7.6      | 1.65      | 7.5      | 1.80      | 7.9      | 1.80      |          |           |          |           |
| 57        | 7.7      | 1.50      | 8.1      | 1.60      | 8.0      | 1.80      | 8.4      | 1.70      |          |           |          |           |
| 55        | 8.0      | 1.45      | 8.5      | 1.55      | 8.3      | 1.75      | 8.6      | 1.65      |          |           |          |           |
| 52        | 8.5      | 1.40      | 9.0      | 1.45      | 8.7      | 1.60      | 9.0      | 1.55      |          |           |          |           |
| 50        | 8.9      | 1.35      |          |           | 9.0      | 1.55      |          |           |          |           |          |           |
| A(°)      | 7~82     |           | 15~82    |           | 30~82    |           | 45~82    |           | 60~82    |           | 75~82    |           |

| ジブオフセット   | 7°       |           | 15°      |           | 30°      |           | 45°      |           | 60°      |           | 75°      |           |
|-----------|----------|-----------|----------|-----------|----------|-----------|----------|-----------|----------|-----------|----------|-----------|
| ブーム角度 (°) | 作業半径 (m) | 定格総荷重 (t) | 作業半径 (m) | 定格総荷重 (t) | 作業半径 (m) | 定格総荷重 (t) | 作業半径 (m) | 定格総荷重 (t) | 作業半径 (m) | 定格総荷重 (t) | 作業半径 (m) | 定格総荷重 (t) |
| 82        | 2.8      | 1.80      | 3.6      | 1.80      | 5.1      | 1.80      | 6.2      | 1.80      | 7.1      | 1.80      | 7.4      | 1.80      |
| 80        | 3.3      | 1.80      | 4.1      | 1.80      | 5.5      | 1.80      | 6.7      | 1.80      | 7.4      | 1.80      | 7.8      | 1.80      |
| 78        | 3.8      | 1.80      | 4.6      | 1.80      | 6.0      | 1.80      | 7.1      | 1.80      | 7.8      | 1.80      | 8.1      | 1.80      |
| 74        | 4.8      | 1.80      | 5.6      | 1.80      | 6.9      | 1.80      | 7.9      | 1.80      | 8.5      | 1.80      |          |           |
| 72        | 5.3      | 1.80      | 6.0      | 1.80      | 7.3      | 1.80      | 8.3      | 1.80      | 8.8      | 1.80      |          |           |
| 70        | 5.7      | 1.80      | 6.5      | 1.80      | 7.8      | 1.80      | 8.7      | 1.80      | 9.1      | 1.80      |          |           |
| 67        | 6.4      | 1.50      | 7.2      | 1.70      | 8.4      | 1.80      | 9.2      | 1.75      | 9.6      | 1.65      |          |           |
| 65        | 6.9      | 1.35      | 7.6      | 1.60      | 8.8      | 1.80      | 9.5      | 1.65      | 9.9      | 1.55      |          |           |
| 62        | 7.6      | 1.20      | 8.3      | 1.45      | 9.3      | 1.65      | 10.0     | 1.50      |          |           |          |           |
| 60        | 8.0      | 1.10      | 8.7      | 1.35      | 9.7      | 1.55      | 10.3     | 1.40      |          |           |          |           |
| 57        | 8.6      | 0.95      | 9.3      | 1.25      | 10.2     | 1.45      | 10.8     | 1.30      |          |           |          |           |
| 55        | 9.0      | 0.90      | 9.6      | 1.15      | 10.6     | 1.35      | 11.1     | 1.25      |          |           |          |           |
| 52        | 9.6      | 0.80      | 10.2     | 1.05      | 11.0     | 1.25      | 11.4     | 1.15      |          |           |          |           |
| 50        | 10.0     | 0.75      | 10.5     | 1.00      | 11.3     | 1.15      | 11.7     | 1.10      |          |           |          |           |
| 45        |          |           |          |           | 12.0     | 1.00      |          |           |          |           |          |           |
| A(°)      | 7~82     |           | 15~82    |           | 30~82    |           | 45~82    |           | 60~82    |           | 75~82    |           |

| ジブオフセット   | 7°       |           | 15°      |           | 30°      |           | 45°      |           | 60°      |           | 75°      |           |
|-----------|----------|-----------|----------|-----------|----------|-----------|----------|-----------|----------|-----------|----------|-----------|
| ブーム角度 (°) | 作業半径 (m) | 定格総荷重 (t) | 作業半径 (m) | 定格総荷重 (t) | 作業半径 (m) | 定格総荷重 (t) | 作業半径 (m) | 定格総荷重 (t) | 作業半径 (m) | 定格総荷重 (t) | 作業半径 (m) | 定格総荷重 (t) |
| 82        | 3.4      | 1.20      | 4.6      | 1.20      | 6.6      | 1.20      | 8.2      | 1.20      | 9.3      | 1.20      | 9.8      | 1.20      |
| 80        | 4.0      | 1.20      | 5.2      | 1.20      | 7.1      | 1.20      | 8.7      | 1.20      | 9.7      | 1.20      | 10.2     | 1.20      |
| 78        | 4.6      | 1.20      | 5.7      | 1.20      | 7.7      | 1.20      | 9.2      | 1.20      | 10.1     | 1.20      |          |           |
| 74        | 5.8      | 1.20      | 6.8      | 1.20      | 8.7      | 1.20      | 10.0     | 1.20      | 10.8     | 1.20      |          |           |
| 72        | 6.3      | 1.20      | 7.4      | 1.20      | 9.2      | 1.20      | 10.5     | 1.20      | 11.2     | 1.20      |          |           |
| 70        | 6.9      | 1.00      | 7.9      | 1.15      | 9.6      | 1.20      | 10.9     | 1.20      | 11.5     | 1.20      |          |           |
| 67        | 7.7      | 0.85      | 8.7      | 1.05      | 10.3     | 1.20      | 11.5     | 1.20      | 12.0     | 1.20      |          |           |
| 65        | 8.2      | 0.75      | 9.2      | 0.95      | 10.8     | 1.20      | 11.8     | 1.20      |          |           |          |           |
| 62        | 9.0      | 0.65      | 9.9      | 0.85      | 11.4     | 1.15      | 12.4     | 1.15      |          |           |          |           |
| 60        | 9.5      | 0.60      | 10.4     | 0.80      | 11.8     | 1.10      | 12.7     | 1.10      |          |           |          |           |
| 57        | 10.2     | 0.52      | 11.1     | 0.75      | 12.4     | 1.05      | 13.2     | 1.00      |          |           |          |           |
| 55        | 10.7     | 0.48      | 11.5     | 0.70      | 12.8     | 1.00      | 13.5     | 0.95      |          |           |          |           |
| 52        | 11.3     | 0.40      | 12.1     | 0.65      | 13.3     | 0.95      | 13.9     | 0.88      |          |           |          |           |
| 50        | 11.8     | 0.37      | 12.5     | 0.60      | 13.6     | 0.88      | 14.1     | 0.84      |          |           |          |           |
| A(°)      | 20~82    |           | 15~82    |           | 30~82    |           | 45~82    |           | 60~82    |           | 75~82    |           |

| ジブオフセット   | 7°       |           | 15°      |           | 30°      |           | 45°      |           | 60°      |           | 75°      |           |
|-----------|----------|-----------|----------|-----------|----------|-----------|----------|-----------|----------|-----------|----------|-----------|
| ブーム角度 (°) | 作業半径 (m) | 定格総荷重 (t) | 作業半径 (m) | 定格総荷重 (t) | 作業半径 (m) | 定格総荷重 (t) | 作業半径 (m) | 定格総荷重 (t) | 作業半径 (m) | 定格総荷重 (t) | 作業半径 (m) | 定格総荷重 (t) |
| 82        | 4.8      | 0.70      | 6.5      | 0.70      | 9.6      | 0.70      | 12.1     | 0.68      | 13.7     | 0.60      | 14.5     | 0.55      |
| 80        | 5.5      | 0.70      | 7.3      | 0.70      | 10.3     | 0.70      | 12.6     | 0.68      | 14.2     | 0.59      | 14.8     | 0.55      |
| 78        | 6.3      | 0.70      | 8.0      | 0.70      | 10.9     | 0.70      | 13.2     | 0.68      | 14.6     | 0.58      | 15.1     | 0.55      |
| 74        | 7.7      | 0.70      | 9.4      | 0.70      | 12.2     | 0.70      | 14.3     | 0.64      | 15.5     | 0.57      |          |           |
| 72        | 8.4      | 0.63      | 10.1     | 0.70      | 12.8     | 0.70      | 14.8     | 0.63      | 15.8     | 0.56      |          |           |
| 70        | 9.1      | 0.53      | 10.7     | 0.62      | 13.4     | 0.70      | 15.2     | 0.61      | 16.2     | 0.56      |          |           |
| 67        | 10.2     | 0.43      | 11.7     | 0.53      | 14.2     | 0.69      | 15.9     | 0.60      | 16.7     | 0.55      |          |           |
| 65        | 10.8     | 0.35      | 12.3     | 0.48      | 14.7     | 0.68      | 16.3     | 0.59      | 17.0     | 0.55      |          |           |
| 62        | 11.8     | 0.30      | 13.2     | 0.43      | 15.5     | 0.64      | 17.0     | 0.58      |          |           |          |           |
| 60        | 12.4     | 0.27      | 13.8     | 0.40      | 16.0     | 0.62      | 17.3     | 0.57      |          |           |          |           |
| 57        |          |           |          |           | 16.7     | 0.59      | 17.8     | 0.55      |          |           |          |           |
| A(°)      | 35~82    |           | 30~82    |           | 45~82    |           | 60~82    |           | 75~82    |           |          |           |

| ジブオフセット   | 7°       |           | 15°      |           | 30°      |           | 45°      |           | 60°      |           | 75°      |           |
|-----------|----------|-----------|----------|-----------|----------|-----------|----------|-----------|----------|-----------|----------|-----------|
| ブーム角度 (°) | 作業半径 (m) | 定格総荷重 (t) | 作業半径 (m) | 定格総荷重 (t) | 作業半径 (m) | 定格総荷重 (t) | 作業半径 (m) | 定格総荷重 (t) | 作業半径 (m) | 定格総荷重 (t) | 作業半径 (m) | 定格総荷重 (t) |
| 82        | 5.5      | 0.65      | 7.5      | 0.65      | 11.1     | 0.40      | 13.9     | 0.30      | 15.9     | 0.27      | 16.8     | 0.27      |
| 80        | 6.3      | 0.65      | 8.3      | 0.65      | 11.8     | 0.40      | 14.5     | 0.30      | 16.4     | 0.27      | 17.2     | 0.27      |
| 78        | 7.1      | 0.65      | 9.1      | 0.65      | 12.5     | 0.40      | 15.1     | 0.30      | 16.8     | 0.27      |          |           |
| 74        | 8.7      | 0.60      | 10.6     | 0.56      | 13.9     | 0.38      | 16.3     | 0.30      | 17.7     | 0.27      |          |           |
| 72        | 9.5      | 0.50      | 11.4     | 0.53      | 14.5     | 0.37      | 16.8     | 0.30      | 18.1     | 0.27      |          |           |
| 70        | 10.3     | 0.40      | 12.1     | 0.50      | 15.2     | 0.35      | 17.3     | 0.30      | 18.5     | 0.27      |          |           |
| 67        | 11.4     | 0.33      | 13.2     | 0.44      | 16.1     | 0.34      | 18.1     | 0.29      | 19.0     | 0.27      |          |           |
| 65        | 12.2     | 0.29      | 13.9     | 0.40      | 16.7     | 0.33      | 18.5     | 0.28      |          |           |          |           |
| 62        | 13.2     | 0.24      | 14.9     | 0.35      | 17.5     | 0.31      | 19.2     | 0.28      |          |           |          |           |
| 60        | 13.9     | 0.20      | 15.5     | 0.32      | 18.0     | 0.30      | 19.6     | 0.27      |          |           |          |           |
| A(°)      | 45~82    |           | 40~82    |           | 45~82    |           | 60~82    |           | 75~82    |           |          |           |

A: ブーム角度の範囲 (無負荷時)

| ジブオフセット   | ※7°      |           | ※15°     |           | 30°      |           | 45°      |           | 60°      |           | 75°      |           |
|-----------|----------|-----------|----------|-----------|----------|-----------|----------|-----------|----------|-----------|----------|-----------|
| ブーム角度 (°) | 作業半径 (m) | 定格総荷重 (t) | 作業半径 (m) | 定格総荷重 (t) | 作業半径 (m) | 定格総荷重 (t) | 作業半径 (m) | 定格総荷重 (t) | 作業半径 (m) | 定格総荷重 (t) | 作業半径 (m) | 定格総荷重 (t) |
| 82        | 1.8      | 1.80      | 2.5      | 1.80      | 3.0      | 1.80      | 3.8      | 1.80      | 4.3      | 1.80      | 4.6      | 1.80      |
| 80        | 2.2      | 1.80      | 2.8      | 1.80      | 3.3      | 1.80      | 4.0      | 1.80      | 4.5      | 1.80      | 4.8      | 1.80      |
| 78        | 2.6      | 1.80      | 3.2      | 1.80      | 3.6      | 1.80      | 4.3      | 1.80      | 4.8      | 1.80      | 4.9      | 1.80      |
| 74        | 3.3      | 1.80      | 3.9      | 1.80      | 4.2      | 1.80      | 4.8      | 1.80      | 5.2      | 1.80      |          |           |
| 72        | 3.6      | 1.80      | 4.2      | 1.80      | 4.5      | 1.80      | 5.1      | 1.80      | 5.4      | 1.80      |          |           |
| 70        | 3.9      | 1.80      | 4.5      | 1.80      | 4.7      | 1.80      | 5.3      | 1.80      | 5.6      | 1.80      |          |           |
| 67        | 4.4      | 1.70      | 4.9      | 1.75      | 5.1      | 1.80      | 5.6      | 1.80      | 5.9      | 1.80      |          |           |
| 65        | 4.7      | 1.65      | 5.2      | 1.70      | 5.4      | 1.80      | 5.8      | 1.80      | 6.1      | 1.80      |          |           |
| 62        | 5.2      | 1.60      | 5.7      | 1.65      | 5.7      | 1.80      | 6.1      | 1.80      |          |           |          |           |
| 60        | 5.5      | 1.55      | 6.0      | 1.60      | 5.9      | 1.80      | 6.3      | 1.80      |          |           |          |           |
| 57        | 5.9      | 1.50      | 6.4      | 1.55      | 6.3      | 1.80      | 6.6      | 1.80      |          |           |          |           |
| 55        | 6.1      | 1.45      | 6.6      | 1.55      | 6.5      | 1.80      | 6.8      | 1.80      |          |           |          |           |
| 52        | 6.5      | 1.40      | 7.0      | 1.50      | 6.8      | 1.80      | 7.0      | 1.80      |          |           |          |           |
| 50        | 6.8      | 1.40      |          |           | 6.9      | 1.80      |          |           |          |           |          |           |
| A(°)      | 7~82     |           | 15~82    |           | 30~82    |           | 45~82    |           | 60~82    |           | 75~82    |           |

| ジブオフセット   | 7°       |           | 15°      |           | 30°      |           | 45°      |           | 60°      |           | 75°      |           |
|-----------|----------|-----------|----------|-----------|----------|-----------|----------|-----------|----------|-----------|----------|-----------|
| ブーム角度 (°) | 作業半径 (m) | 定格総荷重 (t) | 作業半径 (m) | 定格総荷重 (t) | 作業半径 (m) | 定格総荷重 (t) | 作業半径 (m) | 定格総荷重 (t) | 作業半径 (m) | 定格総荷重 (t) | 作業半径 (m) | 定格総荷重 (t) |
| 82        | 2.3      | 1.80      | 3.1      | 1.80      | 4.6      | 1.80      | 5.8      | 1.80      | 6.6      | 1.80      | 7.0      | 1.80      |
| 80        | 2.7      | 1.80      | 3.5      | 1.80      | 4.9      | 1.80      | 6.1      | 1.80      | 6.8      | 1.80      | 7.2      | 1.80      |
| 78        | 3.1      | 1.80      | 3.9      | 1.80      | 5.3      | 1.80      | 6.4      | 1.80      | 7.1      | 1.80      | 7.4      | 1.80      |
| 74        | 3.9      | 1.80      | 4.6      | 1.80      | 6.0      | 1.80      | 7.0      | 1.80      | 7.6      | 1.80      |          |           |
| 72        | 4.2      | 1.80      | 5.0      | 1.80      | 6.3      | 1.80      | 7.3      | 1.80      | 7.8      | 1.80      |          |           |
| 70        | 4.6      | 1.80      | 5.4      | 1.80      | 6.6      | 1.80      | 7.5      | 1.80      | 8.0      | 1.80      |          |           |
| 67        | 5.2      | 1.55      | 5.9      | 1.65      | 7.1      | 1.80      | 7.9      | 1.80      |          |           |          |           |
| 65        | 5.5      | 1.40      | 6.2      | 1.55      | 7.4      | 1.80      | 8.2      | 1.80      |          |           |          |           |
| 62        | 6.0      | 1.20      | 6.7      | 1.40      | 7.8      | 1.80      | 8.5      | 1.80      |          |           |          |           |
| 60        | 6.4      | 1.10      | 7.0      | 1.35      | 8.1      | 1.80      | 8.7      | 1.80      |          |           |          |           |
| 57        | 6.9      | 1.00      | 7.5      | 1.25      | 8.5      | 1.70      | 9.0      | 1.80      |          |           |          |           |
| 55        | 7.2      | 0.90      | 7.8      | 1.20      | 8.7      | 1.65      |          |           |          |           |          |           |
| 52        | 7.9      | 0.80      | 8.2      | 1.10      | 9.0      | 1.60      |          |           |          |           |          |           |
| 50        |          |           | 8.5      | 1.05      | 9.3      | 1.55      |          |           |          |           |          |           |
| A(°)      | 7~82     |           | 15~82    |           | 30~82    |           | 45~82    |           | 60~82    |           | 75~82    |           |

| ジブオフセット   | 7°       |           | 15°      |           | 30°      |           | 45°      |           | 60°      |           | 75°      |           |
|-----------|----------|-----------|----------|-----------|----------|-----------|----------|-----------|----------|-----------|----------|-----------|
| ブーム角度 (°) | 作業半径 (m) | 定格総荷重 (t) | 作業半径 (m) | 定格総荷重 (t) | 作業半径 (m) | 定格総荷重 (t) | 作業半径 (m) | 定格総荷重 (t) | 作業半径 (m) | 定格総荷重 (t) | 作業半径 (m) | 定格総荷重 (t) |
| 82        | 3.0      | 1.20      | 4.1      | 1.20      | 6.1      | 1.20      | 7.7      | 1.20      | 8.8      | 1.20      | 9.3      | 1.20      |
| 80        | 3.4      | 1.20      | 4.6      | 1.20      | 6.5      | 1.20      | 8.1      | 1.20      | 9.1      | 1.20      | 9.6      | 1.20      |
| 78        | 3.9      | 1.20      | 5.0      | 1.20      | 6.9      | 1.20      | 8.4      | 1.20      | 9.4      | 1.20      |          |           |
| 74        | 4.8      | 1.20      | 5.9      | 1.20      | 7.7      | 1.20      | 9.1      | 1.20      | 9.9      | 1.20      |          |           |
| 72        | 5.3      | 1.20      | 6.4      | 1.20      | 8.1      | 1.20      | 9.4      | 1.20      | 10.2     | 1.20      |          |           |
| 70        | 5.8      | 1.05      | 6.8      | 1.15      | 8.5      | 1.20      | 9.7      | 1.20      | 10.4     | 1.20      |          |           |
| 67        | 6.4      | 0.90      | 7.4      | 1.05      | 9.0      | 1.20      | 10.2     | 1.20      | 10.7     | 1.20      |          |           |
| 65        | 6.8      | 0.78      | 7.8      | 0.97      | 9.4      | 1.20      | 10.5     | 1.20      | 10.9     | 1.20      |          |           |
| 62        | 7.5      | 0.68      | 8.4      | 0.85      | 9.9      | 1.15      | 10.8     | 1.20      |          |           |          |           |
| 60        | 7.9      | 0.63      | 8.8      | 0.80      | 10.2     | 1.10      | 11.1     | 1.20      |          |           |          |           |
| 57        | 8.4      | 0.53      | 9.3      | 0.72      | 10.6     | 1.05      | 11.4     | 1.20      |          |           |          |           |
| 55        | 8.8      | 0.48      | 9.7      | 0.68      | 10.9     | 1.00      | 11.6     | 1.20      |          |           |          |           |
| 52        | 9.4      | 0.42      | 10.1     | 0.63      | 11.3     | 0.97      | 11.9     | 1.20      |          |           |          |           |
| 50        | 9.7      | 0.38      | 10.5     | 0.60      | 11.5     | 0.94      | 12.0     | 1.20      |          |           |          |           |
| A(°)      | 7~82     |           | 15~82    |           | 30~82    |           | 45~82    |           | 60~82    |           | 75~82    |           |

| ジブオフセット   | 7°       |           | 15°      |           | 30°      |           | 45°      |           | 60°      |           | 75°      |           |
|-----------|----------|-----------|----------|-----------|----------|-----------|----------|-----------|----------|-----------|----------|-----------|
| ブーム角度 (°) | 作業半径 (m) | 定格総荷重 (t) | 作業半径 (m) | 定格総荷重 (t) | 作業半径 (m) | 定格総荷重 (t) | 作業半径 (m) | 定格総荷重 (t) | 作業半径 (m) | 定格総荷重 (t) | 作業半径 (m) | 定格総荷重 (t) |
| 82        | 4.3      | 0.70      | 6.0      | 0.70      | 9.1      | 0.70      | 11.6     | 0.68      | 13.2     | 0.55      | 14.0     | 0.55      |
| 80        | 4.9      | 0.70      | 6.7      | 0.70      | 9.7      | 0.70      | 12.0     | 0.68      | 13.6     | 0.55      | 14.3     | 0.55      |
| 78        | 5.6      | 0.70      | 7.3      | 0.70      | 10.2     | 0.70      | 12.5     | 0.66      | 13.9     | 0.55      | 14.5     | 0.55      |
| 74        | 6.8      | 0.70      | 8.4      | 0.70      | 11.2     | 0.70      | 13.3     | 0.64      | 14.5     | 0.55      |          |           |
| 72        | 7.4      | 0.65      | 9.0      | 0.70      | 11.7     | 0.70      | 13.7     | 0.63      | 14.8     | 0.55      |          |           |
| 70        | 8.0      | 0.55      | 9.6      | 0.65      | 12.2     | 0.70      | 14.1     | 0.62      | 15.1     | 0.55      |          |           |
| 67        | 8.9      | 0.45      | 10.4     | 0.55      | 12.9     | 0.70      | 14.6     | 0.61      |          |           |          |           |
| 65        | 9.4      | 0.40      | 10.9     | 0.50      | 13.3     | 0.69      | 15.0     | 0.60      |          |           |          |           |
| 62        | 10.3     | 0.33      | 11.7     | 0.43      | 14.0     | 0.65      | 15.4     | 0.58      |          |           |          |           |
| 60        | 10.8     | 0.27      | 12.2     | 0.39      | 14.4     | 0.63      | 15.7     | 0.57      |          |           |          |           |
| 57        |          |           | 12.9     | 0.35      | 14.9     | 0.60      | 16.1     | 0.56      |          |           |          |           |
| A(°)      | 35~82    |           | 15~82    |           | 30~82    |           | 45~82    |           | 60~82    |           | 75~82    |           |

| ジブオフセット   | 7°       |           | 15°      |           | 30°      |           | 45°      |           | 60°      |           | 75°      |           |
|-----------|----------|-----------|----------|-----------|----------|-----------|----------|-----------|----------|-----------|----------|-----------|
| ブーム角度 (°) | 作業半径 (m) | 定格総荷重 (t) | 作業半径 (m) | 定格総荷重 (t) | 作業半径 (m) | 定格総荷重 (t) | 作業半径 (m) | 定格総荷重 (t) | 作業半径 (m) | 定格総荷重 (t) | 作業半径 (m) | 定格総荷重 (t) |
| 82        | 5.0      | 0.65      | 7.0      | 0.65      | 10.6     | 0.40      | 13.4     | 0.30      | 15.4     | 0.27      | 16.3     | 0.27      |
| 80        | 5.7      | 0.65      | 7.7      | 0.65      | 11.2     | 0.40      | 13.9     | 0.30      | 15.8     | 0.27      | 16.5     | 0.27      |
| 78        | 6.4      | 0.65      | 8.4      | 0.65      | 11.8     | 0.40      | 14.4     | 0.30      | 16.1     | 0.27      |          |           |
| 74        | 7.8      | 0.55      | 9.7      | 0.56      | 12.9     | 0.38      | 15.4     | 0.30      | 16.8     | 0.27      |          |           |
| 72        | 8.5      | 0.50      | 10.4     | 0.53      | 13.5     | 0.37      | 15.8     | 0.29      | 17.1     | 0.27      |          |           |
| 70        | 9.1      | 0.43      | 11.0     | 0.50      | 14.0     | 0.36      | 16.2     | 0.29      | 17.4     | 0.27      |          |           |
| 67        | 10.1     | 0.35      | 11.9     | 0.45      | 14.8     | 0.34      | 16.8     | 0.28      | 17.7     | 0.27      |          |           |
| 65        | 10.8     | 0.30      | 12.5     | 0.40      | 15.3     | 0.33      | 17.1     | 0.28      | 18.0     | 0.27      |          |           |
| 62        | 11.7     | 0.25      | 13.4     | 0.33      | 16.0     | 0.32      | 17.6     | 0.27      |          |           |          |           |
| 60        |          |           | 13.9     | 0.30      | 16.4     | 0.31      | 17.9     | 0.27      |          |           |          |           |
| A(°)      | 45~82    |           | 35~82    |           | 30~82    |           | 45~82    |           | 60~82    |           | 75~82    |           |

A: ブーム角度の範囲 (無負荷時)

| 15.0mブーム+4.1mジブ |          |           |          |           |          |           |          |           |          |           |          |           |
|-----------------|----------|-----------|----------|-----------|----------|-----------|----------|-----------|----------|-----------|----------|-----------|
| ジブオフセット         | ※7°      |           | ※15°     |           | 30°      |           | 45°      |           | 60°      |           | 75°      |           |
| ブーム角度 (°)       | 作業半径 (m) | 定格総荷重 (t) | 作業半径 (m) | 定格総荷重 (t) | 作業半径 (m) | 定格総荷重 (t) | 作業半径 (m) | 定格総荷重 (t) | 作業半径 (m) | 定格総荷重 (t) | 作業半径 (m) | 定格総荷重 (t) |
| 82              | 3.3      | 1.80      | 4.0      | 1.80      | 4.6      | 1.80      | 5.4      | 1.80      | 5.9      | 1.80      | 6.1      | 1.80      |
| 80              | 4.0      | 1.80      | 4.7      | 1.80      | 5.3      | 1.80      | 6.0      | 1.80      | 6.4      | 1.80      | 6.6      | 1.80      |
| 78              | 4.8      | 1.80      | 5.3      | 1.80      | 5.9      | 1.80      | 6.6      | 1.80      | 7.0      | 1.80      | 7.1      | 1.80      |
| 74              | 6.1      | 1.80      | 6.7      | 1.80      | 7.1      | 1.80      | 7.7      | 1.75      | 8.1      | 1.70      |          |           |
| 72              | 6.8      | 1.75      | 7.4      | 1.65      | 7.7      | 1.60      | 8.2      | 1.55      | 8.6      | 1.45      |          |           |
| 70              | 7.5      | 1.65      | 8.0      | 1.50      | 8.2      | 1.45      | 8.8      | 1.30      | 9.1      | 1.20      |          |           |
| 67              | 8.4      | 1.25      | 8.9      | 1.15      | 9.1      | 1.10      | 9.6      | 1.00      | 9.8      | 0.95      |          |           |
| 65              | 9.0      | 1.00      | 9.5      | 0.95      | 9.6      | 0.90      | 10.1     | 0.80      | 10.3     | 0.75      |          |           |
| 62              | 9.9      | 0.75      | 10.4     | 0.65      | 10.4     | 0.65      | 10.8     | 0.60      | 11.0     | 0.55      |          |           |
| 60              |          |           | 10.9     | 0.50      | 10.9     | 0.50      | 11.3     | 0.45      |          |           |          |           |
| 57              |          |           |          |           |          |           | 12.0     | 0.25      |          |           |          |           |
| A(°)            | 52~82    |           |          |           |          |           | 60~82    |           |          | 75~82     |          |           |

| 15.0mブーム+6.5mジブ |          |           |          |           |          |           |          |           |          |           |          |           |  |
|-----------------|----------|-----------|----------|-----------|----------|-----------|----------|-----------|----------|-----------|----------|-----------|--|
| ジブオフセット         | 7°       |           | 15°      |           | 30°      |           | 45°      |           | 60°      |           | 75°      |           |  |
| ブーム角度 (°)       | 作業半径 (m) | 定格総荷重 (t) | 作業半径 (m) | 定格総荷重 (t) | 作業半径 (m) | 定格総荷重 (t) | 作業半径 (m) | 定格総荷重 (t) | 作業半径 (m) | 定格総荷重 (t) | 作業半径 (m) | 定格総荷重 (t) |  |
| 82              | 4.0      | 1.80      | 4.8      | 1.80      | 6.3      | 1.80      | 7.5      | 1.80      | 8.3      | 1.65      | 8.6      | 1.65      |  |
| 80              | 4.7      | 1.80      | 5.6      | 1.80      | 7.0      | 1.80      | 8.1      | 1.80      | 8.8      | 1.65      | 9.1      | 1.65      |  |
| 78              | 5.5      | 1.80      | 6.3      | 1.80      | 7.7      | 1.75      | 8.8      | 1.60      | 9.4      | 1.45      | 9.6      | 1.40      |  |
| 74              | 6.9      | 1.80      | 7.7      | 1.80      | 9.0      | 1.40      | 10.0     | 1.15      | 10.5     | 1.05      |          |           |  |
| 72              | 7.6      | 1.65      | 8.3      | 1.50      | 9.6      | 1.20      | 10.6     | 1.00      | 11.1     | 0.88      |          |           |  |
| 70              | 8.2      | 1.45      | 9.0      | 1.25      | 10.3     | 0.95      | 11.2     | 0.80      | 11.6     | 0.75      |          |           |  |
| 67              | 9.2      | 1.05      | 10.0     | 0.90      | 11.2     | 0.70      | 12.0     | 0.60      | 12.4     | 0.55      |          |           |  |
| 65              | 9.9      | 0.80      | 10.6     | 0.70      | 11.8     | 0.55      | 12.5     | 0.45      | 12.8     | 0.43      |          |           |  |
| 62              | 10.8     | 0.60      | 11.5     | 0.45      | 12.6     | 0.35      |          |           |          |           |          |           |  |
| 60              | 11.5     | 0.40      | 12.1     | 0.30      | 13.2     | 0.20      |          |           |          |           |          |           |  |
| A(°)            | 52~82    |           | 55~82    |           |          | 57~82     |          |           | 60~82    |           | 75~82    |           |  |

| 15.0mブーム+8.9mジブ |          |           |          |           |          |           |          |           |          |           |          |           |
|-----------------|----------|-----------|----------|-----------|----------|-----------|----------|-----------|----------|-----------|----------|-----------|
| ジブオフセット         | 7°       |           | 15°      |           | 30°      |           | 45°      |           | 60°      |           | 75°      |           |
| ブーム角度 (°)       | 作業半径 (m) | 定格総荷重 (t) | 作業半径 (m) | 定格総荷重 (t) | 作業半径 (m) | 定格総荷重 (t) | 作業半径 (m) | 定格総荷重 (t) | 作業半径 (m) | 定格総荷重 (t) | 作業半径 (m) | 定格総荷重 (t) |
| 82              | 4.7      | 1.20      | 5.9      | 1.20      | 7.9      | 1.20      | 9.5      | 1.20      | 10.5     | 1.20      | 11.0     | 0.95      |
| 80              | 5.5      | 1.20      | 6.7      | 1.20      | 8.7      | 1.20      | 10.2     | 1.20      | 11.2     | 1.20      | 11.5     | 0.95      |
| 78              | 6.3      | 1.20      | 7.4      | 1.20      | 9.4      | 1.20      | 10.8     | 1.10      | 11.8     | 1.00      | 12.0     | 0.95      |
| 74              | 7.8      | 1.20      | 9.0      | 1.20      | 10.8     | 1.00      | 12.2     | 0.80      | 12.9     | 0.70      |          |           |
| 72              | 8.6      | 1.10      | 9.7      | 1.05      | 11.5     | 0.80      | 12.8     | 0.70      | 13.5     | 0.60      |          |           |
| 70              | 9.4      | 1.00      | 10.5     | 0.95      | 12.2     | 0.65      | 13.4     | 0.57      | 14.0     | 0.50      |          |           |
| 67              | 10.5     | 0.80      | 11.5     | 0.70      | 13.2     | 0.45      | 14.3     | 0.38      | 14.8     | 0.35      |          |           |
| 65              | 11.2     | 0.65      | 12.2     | 0.55      | 13.8     | 0.30      | 14.9     | 0.26      |          |           |          |           |
| 62              | 12.3     | 0.45      | 13.2     | 0.30      |          |           |          |           |          |           |          |           |
| 60              | 12.9     | 0.30      | 13.9     | 0.20      |          |           |          |           |          |           |          |           |
| A(°)            | 55~82    |           |          | 57~82     |          |           | 60~82    |           |          | 75~82     |          |           |

| 15.0mブーム+13.6mジブ |          |           |          |           |          |           |          |           |          |           |          |           |
|------------------|----------|-----------|----------|-----------|----------|-----------|----------|-----------|----------|-----------|----------|-----------|
| ジブオフセット          | 7°       |           | 15°      |           | 30°      |           | 45°      |           | 60°      |           | 75°      |           |
| ブーム角度 (°)        | 作業半径 (m) | 定格総荷重 (t) | 作業半径 (m) | 定格総荷重 (t) | 作業半径 (m) | 定格総荷重 (t) | 作業半径 (m) | 定格総荷重 (t) | 作業半径 (m) | 定格総荷重 (t) | 作業半径 (m) | 定格総荷重 (t) |
| 82               | 6.1      | 0.70      | 7.9      | 0.70      | 11.0     | 0.70      | 13.4     | 0.65      | 14.9     | 0.58      | 15.6     | 0.55      |
| 80               | 7.0      | 0.70      | 8.8      | 0.70      | 11.9     | 0.70      | 14.2     | 0.65      | 15.6     | 0.58      | 16.1     | 0.55      |
| 78               | 8.0      | 0.70      | 9.7      | 0.70      | 12.7     | 0.70      | 14.9     | 0.65      | 16.3     | 0.56      | 16.7     | 0.52      |
| 74               | 9.9      | 0.70      | 11.6     | 0.70      | 14.4     | 0.70      | 16.4     | 0.50      | 17.5     | 0.40      |          |           |
| 72               | 10.8     | 0.60      | 12.4     | 0.70      | 15.2     | 0.53      | 17.1     | 0.38      | 18.1     | 0.29      |          |           |
| 70               | 11.7     | 0.50      | 13.3     | 0.60      | 16.0     | 0.42      | 17.8     | 0.27      |          |           |          |           |
| 67               | 13.0     | 0.45      | 14.6     | 0.45      | 17.1     | 0.28      |          |           |          |           |          |           |
| 65               | 13.9     | 0.35      |          |           |          |           |          |           |          |           |          |           |
| A(°)             | 57~82    |           |          | 62~82     |          |           | 65~82    |           | 67~82    |           | 75~82    |           |

| 15.0mブーム+15.9mジブ |          |           |          |           |          |           |          |           |          |           |          |           |
|------------------|----------|-----------|----------|-----------|----------|-----------|----------|-----------|----------|-----------|----------|-----------|
| ジブオフセット          | 7°       |           | 15°      |           | 30°      |           | 45°      |           | 60°      |           | 75°      |           |
| ブーム角度 (°)        | 作業半径 (m) | 定格総荷重 (t) | 作業半径 (m) | 定格総荷重 (t) | 作業半径 (m) | 定格総荷重 (t) | 作業半径 (m) | 定格総荷重 (t) | 作業半径 (m) | 定格総荷重 (t) | 作業半径 (m) | 定格総荷重 (t) |
| 82               | 6.8      | 0.65      | 8.8      | 0.65      | 12.3     | 0.40      | 15.1     | 0.30      | 17.0     | 0.27      | 17.9     | 0.27      |
| 80               | 7.8      | 0.65      | 9.9      | 0.65      | 13.3     | 0.40      | 16.0     | 0.30      | 17.7     | 0.27      | 18.4     | 0.27      |
| 78               | 8.9      | 0.65      | 10.9     | 0.60      | 14.2     | 0.40      | 16.8     | 0.30      | 18.4     | 0.27      | 19.0     | 0.27      |
| 74               | 10.9     | 0.55      | 12.8     | 0.52      | 16.0     | 0.37      | 18.3     | 0.30      | 19.7     | 0.27      |          |           |
| 72               | 11.9     | 0.45      | 13.8     | 0.49      | 16.8     | 0.36      | 19.1     | 0.29      | 20.3     | 0.25      |          |           |
| 70               | 12.8     | 0.40      | 14.7     | 0.45      | 17.7     | 0.33      | 19.8     | 0.25      | 20.9     | 0.21      |          |           |
| 67               | 14.3     | 0.33      | 16.1     | 0.34      | 18.9     | 0.23      |          |           |          |           |          |           |
| 65               | 15.2     | 0.28      | 17.0     | 0.25      |          |           |          |           |          |           |          |           |
| A(°)             | 60~82    |           |          | 62~82     |          |           | 67~82    |           |          | 75~82     |          |           |

A: ブーム角度の範囲 (無負荷時)

| 11.8mブーム+4.1mジブ |          |           |          |           |          |           |          |           |          |           |          |           |       |  |
|-----------------|----------|-----------|----------|-----------|----------|-----------|----------|-----------|----------|-----------|----------|-----------|-------|--|
| ジブオフセット         | ※7°      |           | ※15°     |           | 30°      |           | 45°      |           | 60°      |           | 75°      |           |       |  |
| ブーム角度 (°)       | 作業半径 (m) | 定格総荷重 (t) | 作業半径 (m) | 定格総荷重 (t) | 作業半径 (m) | 定格総荷重 (t) | 作業半径 (m) | 定格総荷重 (t) | 作業半径 (m) | 定格総荷重 (t) | 作業半径 (m) | 定格総荷重 (t) |       |  |
| 82              | 2.8      | 1.80      | 3.4      | 1.80      | 4.0      | 1.80      | 4.8      | 1.80      | 5.3      | 1.80      | 5.5      | 1.80      |       |  |
| 80              | 3.4      | 1.80      | 3.9      | 1.80      | 4.5      | 1.80      | 5.3      | 1.80      | 5.7      | 1.80      | 5.9      | 1.80      |       |  |
| 78              | 3.9      | 1.80      | 4.6      | 1.80      | 5.1      | 1.80      | 5.7      | 1.80      | 6.2      | 1.80      |          |           |       |  |
| 74              | 5.1      | 1.80      | 5.7      | 1.80      | 6.0      | 1.80      | 6.7      | 1.80      | 7.0      | 1.80      |          |           |       |  |
| 72              | 5.6      | 1.80      | 6.1      | 1.80      | 6.5      | 1.80      | 7.1      | 1.80      | 7.4      | 1.75      |          |           |       |  |
| 70              | 6.1      | 1.75      | 6.7      | 1.75      | 7.0      | 1.80      | 7.6      | 1.70      | 7.9      | 1.70      |          |           |       |  |
| 67              | 6.9      | 1.65      | 7.5      | 1.65      | 7.7      | 1.60      | 8.2      | 1.60      | 8.4      | 1.45      |          |           |       |  |
| 65              | 7.5      | 1.60      | 8.0      | 1.50      | 8.1      | 1.50      | 8.6      | 1.40      | 8.8      | 1.30      |          |           |       |  |
| 62              | 8.2      | 1.35      | 8.7      | 1.25      | 8.8      | 1.25      | 9.2      | 1.10      |          |           |          |           |       |  |
| 60              | 8.7      | 1.15      | 9.2      | 1.05      | 9.2      | 1.10      | 9.6      | 0.95      |          |           |          |           |       |  |
| 57              | 9.4      | 0.95      | 9.9      | 0.80      | 9.8      | 0.85      | 10.1     | 0.75      |          |           |          |           |       |  |
| 55              | 9.8      | 0.80      | 10.3     | 0.70      | 10.2     | 0.73      | 10.5     | 0.65      |          |           |          |           |       |  |
| 52              | 10.5     | 0.60      | 11.0     | 0.50      | 10.7     | 0.55      | 11.0     | 0.50      |          |           |          |           |       |  |
| 50              | 10.9     | 0.45      |          |           | 11.1     | 0.43      |          |           |          |           |          |           |       |  |
| A(°)            | 35~82    |           |          |           | 40~82    |           |          |           | 45~82    |           | 60~82    |           | 75~82 |  |

| 11.8mブーム+6.5mジブ |          |           |          |           |          |           |          |           |          |           |          |           |
|-----------------|----------|-----------|----------|-----------|----------|-----------|----------|-----------|----------|-----------|----------|-----------|
| ジブオフセット         | 7°       |           | 15°      |           | 30°      |           | 45°      |           | 60°      |           | 75°      |           |
| ブーム角度 (°)       | 作業半径 (m) | 定格総荷重 (t) | 作業半径 (m) | 定格総荷重 (t) | 作業半径 (m) | 定格総荷重 (t) | 作業半径 (m) | 定格総荷重 (t) | 作業半径 (m) | 定格総荷重 (t) | 作業半径 (m) | 定格総荷重 (t) |
| 82              | 3.3      | 1.80      | 4.2      | 1.80      | 5.6      | 1.80      | 6.8      | 1.80      | 7.6      | 1.80      | 8.0      | 1.60      |
| 80              | 4.0      | 1.80      | 4.8      | 1.80      | 6.2      | 1.80      | 7.3      | 1.80      | 8.1      | 1.80      | 8.4      | 1.60      |
| 78              | 4.6      | 1.80      | 5.4      | 1.80      | 6.8      | 1.80      | 7.9      | 1.80      | 8.6      | 1.75      | 8.8      | 1.60      |
| 74              | 5.8      | 1.80      | 6.6      | 1.80      | 7.9      | 1.80      | 8.9      | 1.60      | 9.5      | 1.40      |          |           |
| 72              | 6.4      | 1.80      | 7.1      | 1.80      | 8.4      | 1.60      | 9.4      | 1.40      | 9.9      | 1.25      |          |           |
| 70              | 6.9      | 1.70      | 7.7      | 1.75      | 9.0      | 1.40      | 9.9      | 1.20      | 10.3     | 1.10      |          |           |
| 67              | 7.8      | 1.45      | 8.5      | 1.40      | 9.7      | 1.15      | 10.5     | 1.00      | 10.9     | 0.90      |          |           |
| 65              | 8.3      | 1.30      | 9.1      | 1.20      | 10.2     | 1.00      | 11.0     | 0.85      | 11.3     | 0.80      |          |           |
| 62              | 9.2      | 1.10      | 9.9      | 0.95      | 10.9     | 0.75      | 11.6     | 0.70      | 11.9     | 0.65      |          |           |
| 60              | 9.7      | 0.95      | 10.4     | 0.80      | 11.4     | 0.65      | 12.0     | 0.60      |          |           |          |           |
| 57              | 10.4     | 0.75      | 11.1     | 0.62      | 12.1     | 0.48      | 12.6     | 0.45      |          |           |          |           |
| 55              | 10.9     | 0.60      | 11.6     | 0.50      | 12.5     | 0.40      | 13.0     | 0.35      |          |           |          |           |
| 52              | 11.6     | 0.40      | 12.2     | 0.35      | 13.1     | 0.28      |          |           |          |           |          |           |
| 50              | 12.1     | 0.30      | 12.7     | 0.25      |          |           |          |           |          |           |          |           |
| A(°)            | 40~82    |           |          |           | 45~82    |           |          |           | 60~82    |           | 75~82    |           |

| 11.8mブーム+8.9mジブ |          |           |          |           |          |           |          |           |          |           |          |           |
|-----------------|----------|-----------|----------|-----------|----------|-----------|----------|-----------|----------|-----------|----------|-----------|
| ジブオフセット         | 7°       |           | 15°      |           | 30°      |           | 45°      |           | 60°      |           | 75°      |           |
| ブーム角度 (°)       | 作業半径 (m) | 定格総荷重 (t) | 作業半径 (m) | 定格総荷重 (t) | 作業半径 (m) | 定格総荷重 (t) | 作業半径 (m) | 定格総荷重 (t) | 作業半径 (m) | 定格総荷重 (t) | 作業半径 (m) | 定格総荷重 (t) |
| 82              | 4.0      | 1.20      | 5.2      | 1.20      | 7.2      | 1.20      | 8.8      | 1.20      | 9.9      | 1.20      | 10.3     | 1.20      |
| 80              | 4.7      | 1.20      | 5.9      | 1.20      | 7.8      | 1.20      | 9.4      | 1.20      | 10.4     | 1.20      | 10.8     | 1.20      |
| 78              | 5.4      | 1.20      | 6.5      | 1.20      | 8.5      | 1.20      | 9.9      | 1.20      | 10.9     | 1.20      |          |           |
| 74              | 6.8      | 1.20      | 7.9      | 1.20      | 9.7      | 1.20      | 11.0     | 1.10      | 11.8     | 1.00      |          |           |
| 72              | 7.4      | 1.15      | 8.5      | 1.20      | 10.3     | 1.20      | 11.6     | 0.95      | 12.3     | 0.85      |          |           |
| 70              | 8.1      | 1.00      | 9.1      | 1.10      | 10.9     | 1.00      | 12.1     | 0.83      | 12.7     | 0.75      |          |           |
| 67              | 9.0      | 0.85      | 10.1     | 0.98      | 11.7     | 0.80      | 12.8     | 0.68      | 13.4     | 0.62      |          |           |
| 65              | 9.7      | 0.75      | 10.7     | 0.90      | 12.3     | 0.70      | 13.3     | 0.60      | 13.8     | 0.55      |          |           |
| 62              | 10.6     | 0.65      | 11.5     | 0.70      | 13.0     | 0.55      | 14.0     | 0.45      |          |           |          |           |
| 60              | 11.2     | 0.60      | 12.1     | 0.57      | 13.5     | 0.44      | 14.4     | 0.36      |          |           |          |           |
| 57              | 12.0     | 0.50      | 12.9     | 0.40      | 14.3     | 0.30      | 15.0     | 0.25      |          |           |          |           |
| 55              | 12.6     | 0.40      | 13.4     | 0.33      | 14.7     | 0.25      |          |           |          |           |          |           |
| 52              | 13.4     | 0.30      | 14.2     | 0.22      |          |           |          |           |          |           |          |           |
| 50              | 13.9     | 0.20      |          |           |          |           |          |           |          |           |          |           |
| A(°)            | 45~82    |           |          |           | 50~82    |           |          |           | 60~82    |           | 75~82    |           |

| 11.8mブーム+13.6mジブ |          |           |          |           |          |           |          |           |          |           |          |           |       |  |
|------------------|----------|-----------|----------|-----------|----------|-----------|----------|-----------|----------|-----------|----------|-----------|-------|--|
| ジブオフセット          | 7°       |           | 15°      |           | 30°      |           | 45°      |           | 60°      |           | 75°      |           |       |  |
| ブーム角度 (°)        | 作業半径 (m) | 定格総荷重 (t) | 作業半径 (m) | 定格総荷重 (t) | 作業半径 (m) | 定格総荷重 (t) | 作業半径 (m) | 定格総荷重 (t) | 作業半径 (m) | 定格総荷重 (t) | 作業半径 (m) | 定格総荷重 (t) |       |  |
| 82               | 5.4      | 0.70      | 7.2      | 0.70      | 10.2     | 0.70      | 12.7     | 0.70      | 14.3     | 0.58      | 15.0     | 0.55      |       |  |
| 80               | 6.2      | 0.70      | 8.0      | 0.70      | 11.0     | 0.70      | 13.4     | 0.69      | 14.8     | 0.58      | 15.5     | 0.55      |       |  |
| 78               | 7.1      | 0.70      | 8.8      | 0.70      | 11.8     | 0.70      | 14.0     | 0.67      | 15.4     | 0.58      |          |           |       |  |
| 74               | 8.7      | 0.70      | 10.4     | 0.70      | 13.2     | 0.70      | 15.3     | 0.63      | 16.4     | 0.55      |          |           |       |  |
| 72               | 9.5      | 0.65      | 11.2     | 0.70      | 13.9     | 0.70      | 15.9     | 0.56      | 16.9     | 0.50      |          |           |       |  |
| 70               | 10.3     | 0.55      | 12.0     | 0.60      | 14.6     | 0.65      | 16.5     | 0.50      | 17.4     | 0.40      |          |           |       |  |
| 67               | 11.5     | 0.45      | 13.1     | 0.55      | 15.6     | 0.50      | 17.3     | 0.40      | 18.0     | 0.20      |          |           |       |  |
| 65               | 12.3     | 0.39      | 13.8     | 0.50      | 16.2     | 0.43      | 17.8     | 0.28      |          |           |          |           |       |  |
| 62               | 13.4     | 0.33      | 14.9     | 0.45      | 17.1     | 0.33      |          |           |          |           |          |           |       |  |
| 60               | 14.1     | 0.29      | 15.5     | 0.36      |          |           |          |           |          |           |          |           |       |  |
| 57               | 15.2     | 0.24      |          |           |          |           |          |           |          |           |          |           |       |  |
| A(°)             | 45~82    |           |          |           | 50~82    |           |          |           | 52~82    |           | 60~82    |           | 75~82 |  |

| 11.8mブーム+15.9mジブ |          |           |          |           |          |           |          |           |          |           |          |           |       |  |       |  |
|------------------|----------|-----------|----------|-----------|----------|-----------|----------|-----------|----------|-----------|----------|-----------|-------|--|-------|--|
| ジブオフセット          | 7°       |           | 15°      |           | 30°      |           | 45°      |           | 60°      |           | 75°      |           |       |  |       |  |
| ブーム角度 (°)        | 作業半径 (m) | 定格総荷重 (t) | 作業半径 (m) | 定格総荷重 (t) | 作業半径 (m) | 定格総荷重 (t) | 作業半径 (m) | 定格総荷重 (t) | 作業半径 (m) | 定格総荷重 (t) | 作業半径 (m) | 定格総荷重 (t) |       |  |       |  |
| 82               | 6.1      | 0.65      | 8.1      | 0.65      | 11.6     | 0.40      | 14.5     | 0.30      | 16.4     | 0.27      | 17.3     | 0.27      |       |  |       |  |
| 80               | 7.0      | 0.65      | 9.0      | 0.65      | 12.5     | 0.40      | 15.2     | 0.30      | 17.0     | 0.27      | 17.7     | 0.27      |       |  |       |  |
| 78               | 7.9      | 0.65      | 9.9      | 0.60      | 13.3     | 0.40      | 15.9     | 0.30      | 17.6     | 0.27      | 18.2     | 0.27      |       |  |       |  |
| 74               | 9.8      | 0.60      | 11.7     | 0.53      | 14.9     | 0.38      | 17.3     | 0.30      | 18.7     | 0.27      |          |           |       |  |       |  |
| 72               | 10.6     | 0.48      | 12.5     | 0.51      | 15.6     | 0.37      | 17.9     | 0.29      | 19.2     | 0.27      |          |           |       |  |       |  |
| 70               | 11.5     | 0.42      | 13.4     | 0.48      | 16.4     | 0.35      | 18.5     | 0.28      | 19.7     | 0.27      |          |           |       |  |       |  |
| 67               | 12.8     | 0.32      | 14.6     | 0.42      | 17.4     | 0.33      | 19.4     | 0.27      | 20.3     | 0.27      |          |           |       |  |       |  |
| 65               | 13.6     | 0.27      | 15.4     | 0.38      | 18.1     | 0.31      | 20.0     | 0.25      | 20.8     | 0.22      |          |           |       |  |       |  |
| 62               | 14.8     | 0.20      | 16.5     | 0.32      | 19.1     | 0.24      |          |           |          |           |          |           |       |  |       |  |
| 60               |          |           | 17.2     | 0.27      |          |           |          |           |          |           |          |           |       |  |       |  |
| A(°)             | 52~82    |           |          |           | 55~82    |           |          |           | 57~82    |           | 60~82    |           | 62~82 |  | 75~82 |  |

| ジブオフセット   | ※7°      |           | ※15°     |           | 30°      |           | 45°      |           | 60°      |           | 75°      |           |
|-----------|----------|-----------|----------|-----------|----------|-----------|----------|-----------|----------|-----------|----------|-----------|
| ブーム角度 (°) | 作業半径 (m) | 定格総荷重 (t) | 作業半径 (m) | 定格総荷重 (t) | 作業半径 (m) | 定格総荷重 (t) | 作業半径 (m) | 定格総荷重 (t) | 作業半径 (m) | 定格総荷重 (t) | 作業半径 (m) | 定格総荷重 (t) |
| 82        | 2.3      | 1.80      | 2.9      | 1.80      | 3.5      | 1.80      | 4.2      | 1.80      | 4.8      | 1.80      | 5.0      | 1.80      |
| 80        | 2.8      | 1.80      | 3.4      | 1.80      | 3.9      | 1.80      | 4.6      | 1.80      | 5.1      | 1.80      | 5.3      | 1.80      |
| 78        | 3.2      | 1.80      | 3.9      | 1.80      | 4.3      | 1.80      | 5.0      | 1.80      | 5.4      | 1.80      | 5.6      | 1.80      |
| 74        | 4.1      | 1.80      | 4.7      | 1.80      | 5.1      | 1.80      | 5.7      | 1.80      | 6.1      | 1.80      |          |           |
| 72        | 4.6      | 1.80      | 5.2      | 1.80      | 5.5      | 1.80      | 6.1      | 1.80      | 6.4      | 1.80      |          |           |
| 70        | 5.0      | 1.80      | 5.6      | 1.80      | 5.8      | 1.80      | 6.4      | 1.80      | 6.7      | 1.80      |          |           |
| 67        | 5.6      | 1.70      | 6.2      | 1.75      | 6.4      | 1.80      | 6.9      | 1.80      | 7.1      | 1.80      |          |           |
| 65        | 6.1      | 1.65      | 6.6      | 1.70      | 6.7      | 1.80      | 7.2      | 1.75      |          |           |          |           |
| 62        | 6.7      | 1.60      | 7.2      | 1.65      | 7.2      | 1.75      | 7.7      | 1.65      |          |           |          |           |
| 60        | 7.1      | 1.55      | 7.6      | 1.60      | 7.5      | 1.65      | 7.9      | 1.60      |          |           |          |           |
| 57        | 7.7      | 1.50      | 8.1      | 1.45      | 8.0      | 1.55      | 8.4      | 1.45      |          |           |          |           |
| 55        | 8.0      | 1.35      | 8.5      | 1.35      | 8.3      | 1.40      | 8.6      | 1.30      |          |           |          |           |
| 52        | 8.5      | 1.20      | 9.0      | 1.15      | 8.7      | 1.20      | 9.0      | 1.15      |          |           |          |           |
| 50        | 8.9      | 1.05      |          |           | 9.0      | 1.10      |          |           |          |           |          |           |
| A(°)      | 7~82     |           | 15~82    |           | 30~82    |           | 45~82    |           | 60~82    |           | 75~82    |           |

| ジブオフセット   | 7°       |           | 15°      |           | 30°      |           | 45°      |           | 60°      |           | 75°      |           |
|-----------|----------|-----------|----------|-----------|----------|-----------|----------|-----------|----------|-----------|----------|-----------|
| ブーム角度 (°) | 作業半径 (m) | 定格総荷重 (t) | 作業半径 (m) | 定格総荷重 (t) | 作業半径 (m) | 定格総荷重 (t) | 作業半径 (m) | 定格総荷重 (t) | 作業半径 (m) | 定格総荷重 (t) | 作業半径 (m) | 定格総荷重 (t) |
| 82        | 2.8      | 1.80      | 3.6      | 1.80      | 5.1      | 1.80      | 6.2      | 1.80      | 7.1      | 1.80      | 7.4      | 1.80      |
| 80        | 3.3      | 1.80      | 4.1      | 1.80      | 5.5      | 1.80      | 6.7      | 1.80      | 7.4      | 1.80      | 7.8      | 1.80      |
| 78        | 3.8      | 1.80      | 4.6      | 1.80      | 6.0      | 1.80      | 7.1      | 1.80      | 7.8      | 1.80      | 8.1      | 1.80      |
| 74        | 4.8      | 1.80      | 5.6      | 1.80      | 6.9      | 1.80      | 7.9      | 1.80      | 8.5      | 1.80      |          |           |
| 72        | 5.3      | 1.80      | 6.0      | 1.80      | 7.3      | 1.80      | 8.3      | 1.75      | 8.8      | 1.65      |          |           |
| 70        | 5.7      | 1.80      | 6.5      | 1.80      | 7.8      | 1.80      | 8.7      | 1.65      | 9.1      | 1.55      |          |           |
| 67        | 6.4      | 1.50      | 7.2      | 1.70      | 8.4      | 1.65      | 9.2      | 1.50      | 9.6      | 1.35      |          |           |
| 65        | 6.9      | 1.35      | 7.6      | 1.60      | 8.8      | 1.50      | 9.5      | 1.35      | 9.9      | 1.25      |          |           |
| 62        | 7.6      | 1.20      | 8.3      | 1.45      | 9.3      | 1.30      | 10.0     | 1.15      |          |           |          |           |
| 60        | 8.0      | 1.10      | 8.7      | 1.35      | 9.7      | 1.15      | 10.3     | 1.05      |          |           |          |           |
| 57        | 8.6      | 0.95      | 9.3      | 1.20      | 10.2     | 1.00      | 10.8     | 0.90      |          |           |          |           |
| 55        | 9.0      | 0.90      | 9.6      | 1.05      | 10.6     | 0.90      | 11.1     | 0.85      |          |           |          |           |
| 52        | 9.6      | 0.80      | 10.2     | 0.90      | 11.0     | 0.75      | 11.4     | 0.73      |          |           |          |           |
| 50        | 10.0     | 0.75      | 10.5     | 0.80      | 11.3     | 0.65      | 11.7     | 0.65      |          |           |          |           |
| A(°)      | 10~82    |           | 15~82    |           | 30~82    |           | 45~82    |           | 60~82    |           | 75~82    |           |

| ジブオフセット   | 7°       |           | 15°      |           | 30°      |           | 45°      |           | 60°      |           | 75°      |           |
|-----------|----------|-----------|----------|-----------|----------|-----------|----------|-----------|----------|-----------|----------|-----------|
| ブーム角度 (°) | 作業半径 (m) | 定格総荷重 (t) | 作業半径 (m) | 定格総荷重 (t) | 作業半径 (m) | 定格総荷重 (t) | 作業半径 (m) | 定格総荷重 (t) | 作業半径 (m) | 定格総荷重 (t) | 作業半径 (m) | 定格総荷重 (t) |
| 82        | 3.4      | 1.20      | 4.6      | 1.20      | 6.6      | 1.20      | 8.2      | 1.20      | 9.3      | 1.20      | 9.8      | 1.20      |
| 80        | 4.0      | 1.20      | 5.2      | 1.20      | 7.1      | 1.20      | 8.7      | 1.20      | 9.7      | 1.20      | 10.2     | 1.20      |
| 78        | 4.6      | 1.20      | 5.7      | 1.20      | 7.7      | 1.20      | 9.2      | 1.20      | 10.1     | 1.20      |          |           |
| 74        | 5.8      | 1.20      | 6.8      | 1.20      | 8.7      | 1.20      | 10.0     | 1.20      | 10.8     | 1.20      |          |           |
| 72        | 6.3      | 1.20      | 7.4      | 1.20      | 9.2      | 1.20      | 10.5     | 1.15      | 11.2     | 1.20      |          |           |
| 70        | 6.9      | 1.00      | 7.9      | 1.15      | 9.6      | 1.20      | 10.9     | 1.10      | 11.5     | 1.05      |          |           |
| 67        | 7.7      | 0.85      | 8.7      | 1.05      | 10.3     | 1.15      | 11.5     | 1.00      | 12.0     | 0.90      |          |           |
| 65        | 8.2      | 0.75      | 9.2      | 0.95      | 10.8     | 1.05      | 11.8     | 0.90      |          |           |          |           |
| 62        | 9.0      | 0.65      | 9.9      | 0.85      | 11.4     | 0.90      | 12.4     | 0.75      |          |           |          |           |
| 60        | 9.5      | 0.60      | 10.4     | 0.80      | 11.8     | 0.80      | 12.7     | 0.65      |          |           |          |           |
| 57        | 10.2     | 0.52      | 11.1     | 0.75      | 12.4     | 0.65      | 13.2     | 0.55      |          |           |          |           |
| 55        | 10.7     | 0.48      | 11.5     | 0.70      | 12.8     | 0.60      | 13.5     | 0.50      |          |           |          |           |
| 52        | 11.3     | 0.40      | 12.1     | 0.63      | 13.3     | 0.50      | 13.9     | 0.45      |          |           |          |           |
| 50        | 11.8     | 0.37      | 12.5     | 0.58      | 13.6     | 0.43      | 14.1     | 0.40      |          |           |          |           |
| A(°)      | 20~82    |           | 25~82    |           | 30~82    |           | 45~82    |           | 60~82    |           | 75~82    |           |

| ジブオフセット   | 7°       |           | 15°      |           | 30°      |           | 45°      |           | 60°      |           | 75°      |           |
|-----------|----------|-----------|----------|-----------|----------|-----------|----------|-----------|----------|-----------|----------|-----------|
| ブーム角度 (°) | 作業半径 (m) | 定格総荷重 (t) | 作業半径 (m) | 定格総荷重 (t) | 作業半径 (m) | 定格総荷重 (t) | 作業半径 (m) | 定格総荷重 (t) | 作業半径 (m) | 定格総荷重 (t) | 作業半径 (m) | 定格総荷重 (t) |
| 82        | 4.8      | 0.70      | 6.5      | 0.70      | 9.6      | 0.70      | 12.1     | 0.68      | 13.7     | 0.60      | 14.5     | 0.55      |
| 80        | 5.5      | 0.70      | 7.3      | 0.70      | 10.3     | 0.70      | 12.6     | 0.68      | 14.2     | 0.59      | 14.8     | 0.55      |
| 78        | 6.3      | 0.70      | 8.0      | 0.70      | 10.9     | 0.70      | 13.2     | 0.68      | 14.6     | 0.58      | 15.1     | 0.55      |
| 74        | 7.7      | 0.70      | 9.4      | 0.70      | 12.2     | 0.70      | 14.3     | 0.64      | 15.5     | 0.57      |          |           |
| 72        | 8.4      | 0.63      | 10.1     | 0.70      | 12.8     | 0.70      | 14.8     | 0.63      | 15.8     | 0.56      |          |           |
| 70        | 9.1      | 0.53      | 10.7     | 0.62      | 13.4     | 0.70      | 15.2     | 0.61      | 16.2     | 0.54      |          |           |
| 67        | 10.2     | 0.43      | 11.7     | 0.53      | 14.2     | 0.69      | 15.9     | 0.60      | 16.7     | 0.48      |          |           |
| 65        | 10.8     | 0.35      | 12.3     | 0.48      | 14.7     | 0.66      | 16.3     | 0.55      | 17.0     | 0.45      |          |           |
| 62        | 11.8     | 0.30      | 13.2     | 0.43      | 15.5     | 0.57      | 17.0     | 0.45      |          |           |          |           |
| 60        | 12.4     | 0.27      | 13.8     | 0.40      | 16.0     | 0.50      | 17.3     | 0.35      |          |           |          |           |
| 57        |          |           |          |           | 16.7     | 0.43      | 17.8     | 0.25      |          |           |          |           |
| A(°)      |          |           | 35~82    |           |          |           | 45~82    |           | 60~82    |           | 75~82    |           |

| ジブオフセット   | 7°       |           | 15°      |           | 30°      |           | 45°      |           | 60°      |           | 75°      |           |
|-----------|----------|-----------|----------|-----------|----------|-----------|----------|-----------|----------|-----------|----------|-----------|
| ブーム角度 (°) | 作業半径 (m) | 定格総荷重 (t) | 作業半径 (m) | 定格総荷重 (t) | 作業半径 (m) | 定格総荷重 (t) | 作業半径 (m) | 定格総荷重 (t) | 作業半径 (m) | 定格総荷重 (t) | 作業半径 (m) | 定格総荷重 (t) |
| 82        | 5.5      | 0.65      | 7.5      | 0.65      | 11.1     | 0.40      | 13.9     | 0.30      | 15.9     | 0.27      | 16.8     | 0.27      |
| 80        | 6.3      | 0.65      | 8.3      | 0.65      | 11.8     | 0.40      | 14.5     | 0.30      | 16.4     | 0.27      | 17.2     | 0.27      |
| 78        | 7.1      | 0.65      | 9.1      | 0.65      | 12.5     | 0.40      | 15.1     | 0.30      | 16.8     | 0.27      |          |           |
| 74        | 8.7      | 0.60      | 10.6     | 0.56      | 13.9     | 0.38      | 16.3     | 0.30      | 17.7     | 0.27      |          |           |
| 72        | 9.5      | 0.50      | 11.4     | 0.53      | 14.5     | 0.37      | 16.8     | 0.30      | 18.1     | 0.27      |          |           |
| 70        | 10.3     | 0.40      | 12.1     | 0.50      | 15.2     | 0.35      | 17.3     | 0.30      | 18.5     | 0.27      |          |           |
| 67        | 11.4     | 0.33      | 13.2     | 0.44      | 16.1     | 0.34      | 18.1     | 0.29      | 19.0     | 0.27      |          |           |
| 65        | 12.2     | 0.29      | 13.9     | 0.40      | 16.7     | 0.33      | 18.5     | 0.28      |          |           |          |           |
| 62        | 13.2     | 0.24      | 14.9     | 0.35      | 17.5     | 0.31      | 19.2     | 0.28      |          |           |          |           |
| 60        | 13.9     | 0.21      | 15.5     | 0.32      | 18.0     | 0.30      | 19.6     | 0.27      |          |           |          |           |
| 57        |          |           |          |           | 18.8     | 0.28      | 20.1     | 0.27      |          |           |          |           |
| A(°)      |          |           | 45~82    |           |          |           | 50~82    |           | 60~82    |           | 75~82    |           |

A：ブーム角度の範囲（無負荷時）

| 5.5mブーム+4.1mジブ |          |           |          |           |          |           |          |           |          |           |          |           |
|----------------|----------|-----------|----------|-----------|----------|-----------|----------|-----------|----------|-----------|----------|-----------|
| ジブオフセット        | ※7°      |           | ※15°     |           | 30°      |           | 45°      |           | 60°      |           | 75°      |           |
| ブーム角度 (°)      | 作業半径 (m) | 定格総荷重 (t) | 作業半径 (m) | 定格総荷重 (t) | 作業半径 (m) | 定格総荷重 (t) | 作業半径 (m) | 定格総荷重 (t) | 作業半径 (m) | 定格総荷重 (t) | 作業半径 (m) | 定格総荷重 (t) |
| 82             | 1.8      | 1.80      | 2.5      | 1.80      | 3.0      | 1.80      | 3.8      | 1.80      | 4.3      | 1.80      | 4.6      | 1.80      |
| 80             | 2.2      | 1.80      | 2.8      | 1.80      | 3.3      | 1.80      | 4.0      | 1.80      | 4.5      | 1.80      | 4.8      | 1.80      |
| 78             | 2.6      | 1.80      | 3.2      | 1.80      | 3.6      | 1.80      | 4.3      | 1.80      | 4.8      | 1.80      | 4.9      | 1.80      |
| 74             | 3.3      | 1.80      | 3.9      | 1.80      | 4.2      | 1.80      | 4.8      | 1.80      | 5.2      | 1.80      |          |           |
| 72             | 3.6      | 1.80      | 4.2      | 1.80      | 4.5      | 1.80      | 5.1      | 1.80      | 5.4      | 1.80      |          |           |
| 70             | 3.9      | 1.80      | 4.5      | 1.80      | 4.7      | 1.80      | 5.3      | 1.80      | 5.6      | 1.80      |          |           |
| 67             | 4.4      | 1.70      | 4.9      | 1.75      | 5.1      | 1.80      | 5.6      | 1.80      | 5.9      | 1.80      |          |           |
| 65             | 4.7      | 1.65      | 5.2      | 1.70      | 5.4      | 1.80      | 5.8      | 1.80      | 6.1      | 1.80      |          |           |
| 62             | 5.2      | 1.60      | 5.7      | 1.65      | 5.7      | 1.80      | 6.1      | 1.80      |          |           |          |           |
| 60             | 5.5      | 1.55      | 6.0      | 1.60      | 5.9      | 1.80      | 6.3      | 1.80      |          |           |          |           |
| 57             | 5.9      | 1.50      | 6.4      | 1.55      | 6.3      | 1.80      | 6.6      | 1.80      |          |           |          |           |
| 55             | 6.1      | 1.45      | 6.6      | 1.55      | 6.5      | 1.80      | 6.8      | 1.80      |          |           |          |           |
| 52             | 6.5      | 1.40      | 7.0      | 1.50      | 6.8      | 1.80      | 7.0      | 1.80      |          |           |          |           |
| 50             | 6.8      | 1.40      |          |           | 6.9      | 1.80      |          |           |          |           |          |           |
| A(°)           | 7~82     |           | 15~82    |           | 30~82    |           | 45~82    |           | 60~82    |           | 75~82    |           |

| 5.5mブーム+6.5mジブ |          |           |          |           |          |           |          |           |          |           |          |           |
|----------------|----------|-----------|----------|-----------|----------|-----------|----------|-----------|----------|-----------|----------|-----------|
| ジブオフセット        | 7°       |           | 15°      |           | 30°      |           | 45°      |           | 60°      |           | 75°      |           |
| ブーム角度 (°)      | 作業半径 (m) | 定格総荷重 (t) | 作業半径 (m) | 定格総荷重 (t) | 作業半径 (m) | 定格総荷重 (t) | 作業半径 (m) | 定格総荷重 (t) | 作業半径 (m) | 定格総荷重 (t) | 作業半径 (m) | 定格総荷重 (t) |
| 82             | 2.3      | 1.80      | 3.1      | 1.80      | 4.6      | 1.80      | 5.8      | 1.80      | 6.6      | 1.80      | 7.0      | 1.80      |
| 80             | 2.7      | 1.80      | 3.5      | 1.80      | 4.9      | 1.80      | 6.1      | 1.80      | 6.8      | 1.80      | 7.2      | 1.80      |
| 78             | 3.1      | 1.80      | 3.9      | 1.80      | 5.3      | 1.80      | 6.4      | 1.80      | 7.1      | 1.80      | 7.4      | 1.80      |
| 74             | 3.9      | 1.80      | 4.6      | 1.80      | 6.0      | 1.80      | 7.0      | 1.80      | 7.6      | 1.80      |          |           |
| 72             | 4.2      | 1.80      | 5.0      | 1.80      | 6.3      | 1.80      | 7.3      | 1.80      | 7.8      | 1.80      |          |           |
| 70             | 4.6      | 1.80      | 5.4      | 1.80      | 6.6      | 1.80      | 7.5      | 1.80      | 8.0      | 1.80      |          |           |
| 67             | 5.2      | 1.55      | 5.9      | 1.65      | 7.1      | 1.80      | 7.9      | 1.80      |          |           |          |           |
| 65             | 5.5      | 1.40      | 6.2      | 1.55      | 7.4      | 1.80      | 8.2      | 1.75      |          |           |          |           |
| 62             | 6.0      | 1.20      | 6.7      | 1.40      | 7.8      | 1.80      | 8.5      | 1.70      |          |           |          |           |
| 60             | 6.4      | 1.10      | 7.0      | 1.35      | 8.1      | 1.80      | 8.7      | 1.65      |          |           |          |           |
| 57             | 6.9      | 1.00      | 7.5      | 1.25      | 8.5      | 1.70      | 9.0      | 1.60      |          |           |          |           |
| 55             | 7.2      | 0.90      | 7.8      | 1.20      | 8.7      | 1.65      |          |           |          |           |          |           |
| 52             | 7.9      | 0.80      | 8.2      | 1.10      | 9.0      | 1.55      |          |           |          |           |          |           |
| 50             |          |           | 8.5      | 1.05      | 9.3      | 1.45      |          |           |          |           |          |           |
| A(°)           | 7~82     |           | 15~82    |           | 30~82    |           | 45~82    |           | 60~82    |           | 75~82    |           |

| 5.5mブーム+8.9mジブ |          |           |          |           |          |           |          |           |          |           |          |           |
|----------------|----------|-----------|----------|-----------|----------|-----------|----------|-----------|----------|-----------|----------|-----------|
| ジブオフセット        | 7°       |           | 15°      |           | 30°      |           | 45°      |           | 60°      |           | 75°      |           |
| ブーム角度 (°)      | 作業半径 (m) | 定格総荷重 (t) | 作業半径 (m) | 定格総荷重 (t) | 作業半径 (m) | 定格総荷重 (t) | 作業半径 (m) | 定格総荷重 (t) | 作業半径 (m) | 定格総荷重 (t) | 作業半径 (m) | 定格総荷重 (t) |
| 82             | 3.0      | 1.20      | 4.1      | 1.20      | 6.1      | 1.20      | 7.7      | 1.20      | 8.8      | 1.20      | 9.3      | 1.20      |
| 80             | 3.4      | 1.20      | 4.6      | 1.20      | 6.5      | 1.20      | 8.1      | 1.20      | 9.1      | 1.20      | 9.6      | 1.20      |
| 78             | 3.9      | 1.20      | 5.0      | 1.20      | 6.9      | 1.20      | 8.4      | 1.20      | 9.4      | 1.20      |          |           |
| 74             | 4.8      | 1.20      | 5.9      | 1.20      | 7.7      | 1.20      | 9.1      | 1.20      | 9.9      | 1.20      |          |           |
| 72             | 5.3      | 1.20      | 6.4      | 1.20      | 8.1      | 1.20      | 9.4      | 1.20      | 10.2     | 1.20      |          |           |
| 70             | 5.8      | 1.05      | 6.8      | 1.15      | 8.5      | 1.20      | 9.7      | 1.20      | 10.4     | 1.20      |          |           |
| 67             | 6.4      | 0.90      | 7.4      | 1.05      | 9.0      | 1.20      | 10.2     | 1.20      | 10.7     | 1.20      |          |           |
| 65             | 6.8      | 0.78      | 7.8      | 0.97      | 9.4      | 1.20      | 10.5     | 1.20      | 10.9     | 1.20      |          |           |
| 62             | 7.5      | 0.68      | 8.4      | 0.85      | 9.9      | 1.15      | 10.8     | 1.20      |          |           |          |           |
| 60             | 7.9      | 0.63      | 8.8      | 0.80      | 10.2     | 1.10      | 11.1     | 1.20      |          |           |          |           |
| 57             | 8.4      | 0.53      | 9.3      | 0.72      | 10.6     | 1.05      | 11.4     | 1.10      |          |           |          |           |
| 55             | 8.8      | 0.48      | 9.7      | 0.68      | 10.9     | 1.00      | 11.6     | 1.05      |          |           |          |           |
| 52             | 9.4      | 0.42      | 10.1     | 0.63      | 11.3     | 0.97      | 11.9     | 1.00      |          |           |          |           |
| 50             | 9.7      | 0.38      | 10.5     | 0.60      | 11.5     | 0.94      | 12.0     | 0.95      |          |           |          |           |
| A(°)           | 7~82     |           | 15~82    |           | 30~82    |           | 45~82    |           | 60~82    |           | 75~82    |           |

| 5.5mブーム+13.6mジブ |          |           |          |           |          |           |          |           |          |           |          |           |
|-----------------|----------|-----------|----------|-----------|----------|-----------|----------|-----------|----------|-----------|----------|-----------|
| ジブオフセット         | 7°       |           | 15°      |           | 30°      |           | 45°      |           | 60°      |           | 75°      |           |
| ブーム角度 (°)       | 作業半径 (m) | 定格総荷重 (t) | 作業半径 (m) | 定格総荷重 (t) | 作業半径 (m) | 定格総荷重 (t) | 作業半径 (m) | 定格総荷重 (t) | 作業半径 (m) | 定格総荷重 (t) | 作業半径 (m) | 定格総荷重 (t) |
| 82              | 4.3      | 0.70      | 6.0      | 0.70      | 9.1      | 0.70      | 11.6     | 0.68      | 13.2     | 0.55      | 14.0     | 0.55      |
| 80              | 4.9      | 0.70      | 6.7      | 0.70      | 9.7      | 0.70      | 12.0     | 0.68      | 13.6     | 0.55      | 14.3     | 0.55      |
| 78              | 5.6      | 0.70      | 7.3      | 0.70      | 10.2     | 0.70      | 12.5     | 0.66      | 13.9     | 0.55      | 14.5     | 0.55      |
| 74              | 6.8      | 0.70      | 8.4      | 0.70      | 11.2     | 0.70      | 13.3     | 0.64      | 14.5     | 0.55      |          |           |
| 72              | 7.4      | 0.65      | 9.0      | 0.70      | 11.7     | 0.70      | 13.7     | 0.63      | 14.8     | 0.55      |          |           |
| 70              | 8.0      | 0.55      | 9.6      | 0.65      | 12.2     | 0.70      | 14.1     | 0.62      | 15.1     | 0.55      |          |           |
| 67              | 8.9      | 0.45      | 10.4     | 0.55      | 12.9     | 0.70      | 14.6     | 0.61      |          |           |          |           |
| 65              | 9.4      | 0.40      | 10.9     | 0.50      | 13.3     | 0.68      | 15.0     | 0.60      |          |           |          |           |
| 62              | 10.3     | 0.33      | 11.7     | 0.43      | 14.0     | 0.65      | 15.4     | 0.58      |          |           |          |           |
| 60              | 10.8     | 0.27      | 12.2     | 0.39      | 14.4     | 0.63      | 15.7     | 0.57      |          |           |          |           |
| 57              |          |           | 12.9     | 0.35      | 14.9     | 0.60      | 16.1     | 0.56      |          |           |          |           |
| A(°)            | 35~82    |           | 15~82    |           | 30~82    |           | 45~82    |           | 60~82    |           | 75~82    |           |

| 5.5mブーム+15.9mジブ |          |           |          |           |          |           |          |           |          |           |          |           |
|-----------------|----------|-----------|----------|-----------|----------|-----------|----------|-----------|----------|-----------|----------|-----------|
| ジブオフセット         | 7°       |           | 15°      |           | 30°      |           | 45°      |           | 60°      |           | 75°      |           |
| ブーム角度 (°)       | 作業半径 (m) | 定格総荷重 (t) | 作業半径 (m) | 定格総荷重 (t) | 作業半径 (m) | 定格総荷重 (t) | 作業半径 (m) | 定格総荷重 (t) | 作業半径 (m) | 定格総荷重 (t) | 作業半径 (m) | 定格総荷重 (t) |
| 82              | 5.0      | 0.65      | 7.0      | 0.65      | 10.6     | 0.40      | 13.4     | 0.30      | 15.4     | 0.27      | 16.3     | 0.27      |
| 80              | 5.7      | 0.65      | 7.7      | 0.65      | 11.2     | 0.40      | 13.9     | 0.30      | 15.8     | 0.27      | 16.5     | 0.27      |
| 78              | 6.4      | 0.65      | 8.4      | 0.65      | 11.8     | 0.40      | 14.4     | 0.30      | 16.1     | 0.27      |          |           |
| 74              | 7.8      | 0.55      | 9.7      | 0.56      | 12.9     | 0.38      | 15.4     | 0.30      | 16.8     | 0.27      |          |           |
| 72              | 8.5      | 0.50      | 10.4     | 0.53      | 13.5     | 0.37      | 15.8     | 0.29      | 17.1     | 0.27      |          |           |
| 70              | 9.1      | 0.43      | 11.0     | 0.50      | 14.0     | 0.36      | 16.2     | 0.29      | 17.4     | 0.27      |          |           |
| 67              | 10.1     | 0.35      | 11.9     | 0.45      | 14.8     | 0.34      | 16.8     | 0.28      | 17.7     | 0.27      |          |           |
| 65              | 10.8     | 0.30      | 12.5     | 0.40      | 15.3     | 0.33      | 17.1     | 0.28      | 18.0     | 0.27      |          |           |
| 62              | 11.7     | 0.25      | 13.4     | 0.33      | 16.0     | 0.32      | 17.6     | 0.27      |          |           |          |           |
| 60              |          |           | 13.9     | 0.30      | 16.4     | 0.31      | 17.9     | 0.27      |          |           |          |           |
| A(°)            | 45~82    |           | 35~82    |           | 30~82    |           | 45~82    |           | 60~82    |           | 75~82    |           |

A: ブーム角度の範囲 (無負荷時)

■定格総荷重表 [補巻作業] アウトリガ中間張出 (2.5m) -側方-

※は5.0mジブ状態を示します。

| 15.0mブーム+4.1mジブ |          |           |          |           |          |           |          |           |          |           |          |           |       |
|-----------------|----------|-----------|----------|-----------|----------|-----------|----------|-----------|----------|-----------|----------|-----------|-------|
| ジブオフセット         | ※7°      |           | ※15°     |           | 30°      |           | 45°      |           | 60°      |           | 75°      |           |       |
| ブーム角度 (°)       | 作業半径 (m) | 定格総荷重 (t) | 作業半径 (m) | 定格総荷重 (t) | 作業半径 (m) | 定格総荷重 (t) | 作業半径 (m) | 定格総荷重 (t) | 作業半径 (m) | 定格総荷重 (t) | 作業半径 (m) | 定格総荷重 (t) |       |
| 82              | 3.3      | 1.80      | 4.0      | 1.80      | 4.6      | 1.80      | 5.4      | 1.80      | 5.9      | 1.25      | 6.1      | 1.25      |       |
| 80              | 4.0      | 1.80      | 4.7      | 1.80      | 5.3      | 1.80      | 6.0      | 1.60      | 6.4      | 1.25      | 6.6      | 1.25      |       |
| 78              | 4.8      | 1.80      | 5.3      | 1.70      | 5.9      | 1.65      | 6.6      | 1.40      | 7.0      | 1.25      | 7.1      | 1.25      |       |
| 74              | 6.1      | 1.25      | 6.7      | 1.10      | 7.1      | 1.00      | 7.7      | 0.85      | 8.1      | 0.75      |          |           |       |
| 72              | 6.8      | 0.95      | 7.4      | 0.80      | 7.7      | 0.80      | 8.2      | 0.65      | 8.6      | 0.60      |          |           |       |
| 70              | 7.5      | 0.70      | 8.0      | 0.60      | 8.2      | 0.55      | 8.8      | 0.45      | 9.1      | 0.40      |          |           |       |
| 67              |          |           |          |           | 9.1      | 0.25      |          |           |          |           |          |           |       |
| A(°)            | 62~82    |           |          |           | 65~82    |           |          |           | 67~82    |           |          |           | 75~82 |

| 15.0mブーム+6.5mジブ |          |           |          |           |          |           |          |           |          |           |          |           |
|-----------------|----------|-----------|----------|-----------|----------|-----------|----------|-----------|----------|-----------|----------|-----------|
| ジブオフセット         | 7°       |           | 15°      |           | 30°      |           | 45°      |           | 60°      |           | 75°      |           |
| ブーム角度 (°)       | 作業半径 (m) | 定格総荷重 (t) | 作業半径 (m) | 定格総荷重 (t) | 作業半径 (m) | 定格総荷重 (t) | 作業半径 (m) | 定格総荷重 (t) | 作業半径 (m) | 定格総荷重 (t) | 作業半径 (m) | 定格総荷重 (t) |
| 82              | 4.0      | 1.80      | 4.8      | 1.80      | 6.3      | 1.35      | 7.5      | 1.05      | 8.3      | 0.80      | 8.6      | 0.85      |
| 80              | 4.7      | 1.80      | 5.6      | 1.80      | 7.0      | 1.35      | 8.1      | 1.05      | 8.8      | 0.80      | 9.1      | 0.85      |
| 78              | 5.5      | 1.80      | 6.3      | 1.50      | 7.7      | 1.00      | 8.8      | 0.75      | 9.4      | 0.65      | 9.6      | 0.65      |
| 74              | 6.9      | 1.05      | 7.7      | 0.80      | 9.0      | 0.60      | 10.0     | 0.45      | 10.5     | 0.35      |          |           |
| 72              | 7.6      | 0.75      | 8.3      | 0.55      | 9.6      | 0.40      | 10.6     | 0.30      | 11.1     | 0.25      |          |           |
| 70              | 8.2      | 0.50      | 9.0      | 0.40      |          |           | 11.2     | 0.20      |          |           |          |           |
| 67              | 9.2      | 0.25      |          |           |          |           |          |           |          |           |          |           |
| A(°)            | 65~82    |           | 67~82    |           |          |           | 70~82    |           |          |           | 75~82    |           |

| 15.0mブーム+8.9mジブ |          |           |          |           |          |           |          |           |          |           |          |           |       |
|-----------------|----------|-----------|----------|-----------|----------|-----------|----------|-----------|----------|-----------|----------|-----------|-------|
| ジブオフセット         | 7°       |           | 15°      |           | 30°      |           | 45°      |           | 60°      |           | 75°      |           |       |
| ブーム角度 (°)       | 作業半径 (m) | 定格総荷重 (t) | 作業半径 (m) | 定格総荷重 (t) | 作業半径 (m) | 定格総荷重 (t) | 作業半径 (m) | 定格総荷重 (t) | 作業半径 (m) | 定格総荷重 (t) | 作業半径 (m) | 定格総荷重 (t) |       |
| 82              | 4.7      | 1.20      | 5.9      | 1.20      | 7.9      | 0.80      | 9.5      | 0.70      | 10.5     | 0.60      | 11.0     | 0.40      |       |
| 80              | 5.5      | 1.20      | 6.7      | 1.20      | 8.7      | 0.80      | 10.2     | 0.70      | 11.2     | 0.60      | 11.5     | 0.40      |       |
| 78              | 6.3      | 1.20      | 7.4      | 1.05      | 9.4      | 0.70      | 10.8     | 0.50      | 11.8     | 0.40      | 12.0     | 0.40      |       |
| 74              | 7.8      | 0.80      | 9.0      | 0.60      | 10.8     | 0.25      | 12.2     | 0.20      |          |           |          |           |       |
| 72              | 8.6      | 0.60      | 9.7      | 0.40      |          |           |          |           |          |           |          |           |       |
| 70              | 9.4      | 0.40      |          |           |          |           |          |           |          |           |          |           |       |
| A(°)            | 67~82    |           |          |           | 70~82    |           |          |           | 72~82    |           |          |           | 75~82 |

| 15.0mブーム+13.6mジブ |          |           |          |           |          |           |          |           |          |           |          |           |
|------------------|----------|-----------|----------|-----------|----------|-----------|----------|-----------|----------|-----------|----------|-----------|
| ジブオフセット          | 7°       |           | 15°      |           | 30°      |           | 45°      |           | 60°      |           | 75°      |           |
| ブーム角度 (°)        | 作業半径 (m) | 定格総荷重 (t) | 作業半径 (m) | 定格総荷重 (t) | 作業半径 (m) | 定格総荷重 (t) | 作業半径 (m) | 定格総荷重 (t) | 作業半径 (m) | 定格総荷重 (t) | 作業半径 (m) | 定格総荷重 (t) |
| 82               | 6.1      | 0.70      | 7.9      | 0.70      | 11.0     | 0.55      | 13.4     | 0.40      |          |           |          |           |
| 80               | 7.0      | 0.70      | 8.8      | 0.70      | 11.9     | 0.55      | 14.2     | 0.40      |          |           |          |           |
| 78               | 8.0      | 0.70      | 9.7      | 0.65      | 12.7     | 0.45      |          |           |          |           |          |           |
| 74               | 9.9      | 0.55      | 11.6     | 0.40      |          |           |          |           |          |           |          |           |
| A(°)             | 67~82    |           |          |           | 72~82    |           |          |           | 74~82    |           |          |           |

| 15.0mブーム+15.9mジブ |          |           |          |           |          |           |          |           |          |           |          |           |
|------------------|----------|-----------|----------|-----------|----------|-----------|----------|-----------|----------|-----------|----------|-----------|
| ジブオフセット          | 7°       |           | 15°      |           | 30°      |           | 45°      |           | 60°      |           | 75°      |           |
| ブーム角度 (°)        | 作業半径 (m) | 定格総荷重 (t) | 作業半径 (m) | 定格総荷重 (t) | 作業半径 (m) | 定格総荷重 (t) | 作業半径 (m) | 定格総荷重 (t) | 作業半径 (m) | 定格総荷重 (t) | 作業半径 (m) | 定格総荷重 (t) |
| 82               | 6.8      | 0.65      | 8.8      | 0.65      | 12.3     | 0.40      | 15.1     | 0.30      |          |           |          |           |
| 80               | 7.8      | 0.65      | 9.9      | 0.65      | 13.3     | 0.40      | 16.0     | 0.30      |          |           |          |           |
| 78               | 8.9      | 0.65      | 10.9     | 0.60      | 14.2     | 0.35      | 16.8     | 0.20      |          |           |          |           |
| 74               | 10.9     | 0.45      | 12.8     | 0.30      |          |           |          |           |          |           |          |           |
| 72               | 11.9     | 0.30      |          |           |          |           |          |           |          |           |          |           |
| A(°)             | 67~82    |           | 70~82    |           | 72~82    |           | 74~82    |           |          |           |          |           |

A: ブーム角度の範囲 (無負荷時)

| 11.8mブーム+4.1mジブ |          |           |          |           |          |           |          |           |          |           |          |           |       |
|-----------------|----------|-----------|----------|-----------|----------|-----------|----------|-----------|----------|-----------|----------|-----------|-------|
| ジブオフセット         | ※7°      |           | ※15°     |           | 30°      |           | 45°      |           | 60°      |           | 75°      |           |       |
| ブーム角度 (°)       | 作業半径 (m) | 定格総荷重 (t) | 作業半径 (m) | 定格総荷重 (t) | 作業半径 (m) | 定格総荷重 (t) | 作業半径 (m) | 定格総荷重 (t) | 作業半径 (m) | 定格総荷重 (t) | 作業半径 (m) | 定格総荷重 (t) |       |
| 82              | 2.8      | 1.80      | 3.4      | 1.80      | 4.0      | 1.80      | 4.8      | 1.80      | 5.3      | 1.80      | 5.5      | 1.80      |       |
| 80              | 3.4      | 1.80      | 3.9      | 1.80      | 4.5      | 1.80      | 5.3      | 1.80      | 5.7      | 1.80      | 5.9      | 1.80      |       |
| 78              | 3.9      | 1.80      | 4.6      | 1.80      | 5.1      | 1.80      | 5.7      | 1.80      | 6.2      | 1.80      |          |           |       |
| 74              | 5.1      | 1.80      | 5.7      | 1.65      | 6.0      | 1.60      | 6.7      | 1.30      | 7.0      | 1.20      |          |           |       |
| 72              | 5.6      | 1.60      | 6.1      | 1.40      | 6.5      | 1.30      | 7.1      | 1.10      | 7.4      | 1.00      |          |           |       |
| 70              | 6.1      | 1.30      | 6.7      | 1.15      | 7.0      | 1.05      | 7.6      | 0.90      | 7.9      | 0.80      |          |           |       |
| 67              | 6.9      | 0.90      | 7.5      | 0.75      | 7.7      | 0.75      | 8.2      | 0.65      | 8.4      | 0.60      |          |           |       |
| 65              | 7.5      | 0.70      | 8.0      | 0.60      | 8.1      | 0.60      | 8.6      | 0.50      | 8.8      | 0.45      |          |           |       |
| 62              | 8.2      | 0.45      | 8.7      | 0.35      | 8.8      | 0.35      | 9.2      | 0.30      |          |           |          |           |       |
| 60              |          |           | 9.2      | 0.25      | 9.2      | 0.25      |          |           |          |           |          |           |       |
| A(°)            | 55~82    |           |          |           | 57~82    |           |          |           | 60~82    |           |          |           | 75~82 |

| 11.8mブーム+6.5mジブ |          |           |          |           |          |           |          |           |          |           |          |           |       |
|-----------------|----------|-----------|----------|-----------|----------|-----------|----------|-----------|----------|-----------|----------|-----------|-------|
| ジブオフセット         | 7°       |           | 15°      |           | 30°      |           | 45°      |           | 60°      |           | 75°      |           |       |
| ブーム角度 (°)       | 作業半径 (m) | 定格総荷重 (t) | 作業半径 (m) | 定格総荷重 (t) | 作業半径 (m) | 定格総荷重 (t) | 作業半径 (m) | 定格総荷重 (t) | 作業半径 (m) | 定格総荷重 (t) | 作業半径 (m) | 定格総荷重 (t) |       |
| 82              | 3.3      | 1.80      | 4.2      | 1.80      | 5.6      | 1.80      | 6.8      | 1.50      | 7.6      | 1.15      | 8.0      | 0.85      |       |
| 80              | 4.0      | 1.80      | 4.8      | 1.80      | 6.2      | 1.80      | 7.3      | 1.35      | 8.1      | 1.15      | 8.4      | 0.85      |       |
| 78              | 4.6      | 1.80      | 5.4      | 1.80      | 6.8      | 1.45      | 7.9      | 1.10      | 8.6      | 0.95      | 8.8      | 0.85      |       |
| 74              | 5.8      | 1.80      | 6.6      | 1.35      | 7.9      | 0.95      | 8.9      | 0.75      | 9.5      | 0.65      |          |           |       |
| 72              | 6.4      | 1.30      | 7.1      | 1.05      | 8.4      | 0.75      | 9.4      | 0.60      | 9.9      | 0.50      |          |           |       |
| 70              | 6.9      | 1.00      | 7.7      | 0.85      | 9.0      | 0.60      | 9.9      | 0.50      | 10.3     | 0.40      |          |           |       |
| 67              | 7.8      | 0.70      | 8.5      | 0.55      | 9.7      | 0.40      | 10.5     | 0.30      | 10.9     | 0.30      |          |           |       |
| 65              | 8.3      | 0.50      | 9.1      | 0.40      | 10.2     | 0.30      | 11.0     | 0.20      |          |           |          |           |       |
| 62              | 9.2      | 0.30      | 9.9      | 0.25      |          |           |          |           |          |           |          |           |       |
| A(°)            | 57~82    |           |          |           | 60~82    |           |          |           | 62~82    |           |          |           | 75~82 |

| 11.8mブーム+8.9mジブ |          |           |          |           |          |           |          |           |          |           |          |           |       |
|-----------------|----------|-----------|----------|-----------|----------|-----------|----------|-----------|----------|-----------|----------|-----------|-------|
| ジブオフセット         | 7°       |           | 15°      |           | 30°      |           | 45°      |           | 60°      |           | 75°      |           |       |
| ブーム角度 (°)       | 作業半径 (m) | 定格総荷重 (t) | 作業半径 (m) | 定格総荷重 (t) | 作業半径 (m) | 定格総荷重 (t) | 作業半径 (m) | 定格総荷重 (t) | 作業半径 (m) | 定格総荷重 (t) | 作業半径 (m) | 定格総荷重 (t) |       |
| 82              | 4.0      | 1.20      | 5.2      | 1.20      | 7.2      | 1.15      | 8.8      | 1.00      | 9.9      | 0.60      | 10.3     | 0.60      |       |
| 80              | 4.7      | 1.20      | 5.9      | 1.20      | 7.8      | 1.15      | 9.4      | 0.90      | 10.4     | 0.60      | 10.8     | 0.60      |       |
| 78              | 5.4      | 1.20      | 6.5      | 1.20      | 8.5      | 1.00      | 9.9      | 0.75      | 10.9     | 0.60      | 11.2     | 0.60      |       |
| 74              | 6.8      | 1.20      | 7.9      | 1.00      | 9.7      | 0.65      | 11.0     | 0.50      | 11.8     | 0.40      |          |           |       |
| 72              | 7.4      | 1.00      | 8.5      | 0.80      | 10.3     | 0.50      | 11.6     | 0.40      |          |           |          |           |       |
| 70              | 8.1      | 0.75      | 9.1      | 0.60      | 10.9     | 0.40      | 12.1     | 0.30      |          |           |          |           |       |
| 67              | 9.0      | 0.55      | 10.1     | 0.40      |          |           |          |           |          |           |          |           |       |
| 65              | 9.7      | 0.35      | 10.7     | 0.25      |          |           |          |           |          |           |          |           |       |
| A(°)            | 60~82    |           | 62~82    |           | 65~82    |           |          |           | 67~82    |           |          |           | 75~82 |

| 11.8mブーム+13.6mジブ |          |           |          |           |          |           |          |           |          |           |          |           |
|------------------|----------|-----------|----------|-----------|----------|-----------|----------|-----------|----------|-----------|----------|-----------|
| ジブオフセット          | 7°       |           | 15°      |           | 30°      |           | 45°      |           | 60°      |           | 75°      |           |
| ブーム角度 (°)        | 作業半径 (m) | 定格総荷重 (t) | 作業半径 (m) | 定格総荷重 (t) | 作業半径 (m) | 定格総荷重 (t) | 作業半径 (m) | 定格総荷重 (t) | 作業半径 (m) | 定格総荷重 (t) | 作業半径 (m) | 定格総荷重 (t) |
| 82               | 5.4      | 0.70      | 7.2      | 0.70      | 10.2     | 0.70      | 12.7     | 0.55      |          |           |          |           |
| 80               | 6.2      | 0.70      | 8.0      | 0.70      | 11.0     | 0.70      | 13.4     | 0.55      |          |           |          |           |
| 78               | 7.1      | 0.70      | 8.8      | 0.70      | 11.8     | 0.60      | 14.0     | 0.40      |          |           |          |           |
| 74               | 8.7      | 0.70      | 10.4     | 0.70      | 13.2     | 0.35      |          |           |          |           |          |           |
| 72               | 9.5      | 0.65      | 11.2     | 0.45      |          |           |          |           |          |           |          |           |
| 70               | 10.3     | 0.55      | 12.0     | 0.35      |          |           |          |           |          |           |          |           |
| A(°)             | 62~82    |           | 65~82    |           | 67~82    |           |          |           |          |           |          |           |

| 11.8mブーム+15.9mジブ |          |           |          |           |          |           |          |           |          |           |          |           |
|------------------|----------|-----------|----------|-----------|----------|-----------|----------|-----------|----------|-----------|----------|-----------|
| ジブオフセット          | 7°       |           | 15°      |           | 30°      |           | 45°      |           | 60°      |           | 75°      |           |
| ブーム角度 (°)        | 作業半径 (m) | 定格総荷重 (t) | 作業半径 (m) | 定格総荷重 (t) | 作業半径 (m) | 定格総荷重 (t) | 作業半径 (m) | 定格総荷重 (t) | 作業半径 (m) | 定格総荷重 (t) | 作業半径 (m) | 定格総荷重 (t) |
| 82               | 6.1      | 0.65      | 8.1      | 0.65      | 11.6     | 0.40      | 14.5     | 0.30      |          |           |          |           |
| 80               | 7.0      | 0.65      | 9.0      | 0.65      | 12.5     | 0.40      | 15.2     | 0.30      |          |           |          |           |
| 78               | 7.9      | 0.65      | 9.9      | 0.60      | 13.3     | 0.40      | 15.9     | 0.30      |          |           |          |           |
| 74               | 9.8      | 0.57      | 11.7     | 0.52      | 14.9     | 0.30      |          |           |          |           |          |           |
| 72               | 10.6     | 0.48      | 12.5     | 0.42      |          |           |          |           |          |           |          |           |
| 70               | 11.5     | 0.40      | 13.4     | 0.30      |          |           |          |           |          |           |          |           |
| A(°)             | 62~82    |           | 65~82    |           | 67~82    |           | 72~82    |           |          |           |          |           |

A: ブーム角度の範囲 (無負荷時)

| 8.7mブーム+4.1mジブ |          |           |          |           |          |           |          |           |          |           |          |           |  |
|----------------|----------|-----------|----------|-----------|----------|-----------|----------|-----------|----------|-----------|----------|-----------|--|
| ジブオフセット        | ※7°      |           | ※15°     |           | 30°      |           | 45°      |           | 60°      |           | 75°      |           |  |
| ブーム角度 (°)      | 作業半径 (m) | 定格総荷重 (t) | 作業半径 (m) | 定格総荷重 (t) | 作業半径 (m) | 定格総荷重 (t) | 作業半径 (m) | 定格総荷重 (t) | 作業半径 (m) | 定格総荷重 (t) | 作業半径 (m) | 定格総荷重 (t) |  |
| 82             | 2.3      | 1.80      | 2.9      | 1.80      | 3.5      | 1.80      | 4.2      | 1.80      | 4.8      | 1.80      | 5.0      | 1.80      |  |
| 80             | 2.8      | 1.80      | 3.4      | 1.80      | 3.9      | 1.80      | 4.6      | 1.80      | 5.1      | 1.80      | 5.3      | 1.80      |  |
| 78             | 3.2      | 1.80      | 3.9      | 1.80      | 4.3      | 1.80      | 5.0      | 1.80      | 5.4      | 1.80      | 5.6      | 1.80      |  |
| 74             | 4.1      | 1.80      | 4.7      | 1.80      | 5.1      | 1.80      | 5.7      | 1.80      | 6.1      | 1.80      |          |           |  |
| 72             | 4.6      | 1.80      | 5.2      | 1.75      | 5.5      | 1.80      | 6.1      | 1.65      | 6.4      | 1.55      |          |           |  |
| 70             | 5.0      | 1.80      | 5.6      | 1.65      | 5.8      | 1.65      | 6.4      | 1.45      | 6.7      | 1.35      |          |           |  |
| 67             | 5.6      | 1.60      | 6.2      | 1.40      | 6.4      | 1.35      | 6.9      | 1.15      | 7.1      | 1.10      |          |           |  |
| 65             | 6.1      | 1.40      | 6.6      | 1.25      | 6.7      | 1.15      | 7.2      | 1.00      |          |           |          |           |  |
| 62             | 6.7      | 1.10      | 7.2      | 0.95      | 7.2      | 0.90      | 7.7      | 0.85      |          |           |          |           |  |
| 60             | 7.1      | 0.95      | 7.6      | 0.80      | 7.5      | 0.75      | 7.9      | 0.70      |          |           |          |           |  |
| 57             | 7.7      | 0.70      | 8.1      | 0.65      | 8.0      | 0.60      | 8.4      | 0.55      |          |           |          |           |  |
| 55             | 8.0      | 0.55      | 8.5      | 0.55      | 8.3      | 0.50      | 8.6      | 0.45      |          |           |          |           |  |
| 52             |          |           | 9.0      | 0.30      | 8.7      | 0.35      | 9.0      | 0.30      |          |           |          |           |  |
| 50             |          |           |          |           | 9.0      | 0.25      |          |           |          |           |          |           |  |
| A(°)           |          |           | 40~82    |           |          |           | 45~82    |           | 60~82    |           | 75~82    |           |  |

| 8.7mブーム+6.5mジブ |          |           |          |           |          |           |          |           |          |           |          |           |  |
|----------------|----------|-----------|----------|-----------|----------|-----------|----------|-----------|----------|-----------|----------|-----------|--|
| ジブオフセット        | 7°       |           | 15°      |           | 30°      |           | 45°      |           | 60°      |           | 75°      |           |  |
| ブーム角度 (°)      | 作業半径 (m) | 定格総荷重 (t) | 作業半径 (m) | 定格総荷重 (t) | 作業半径 (m) | 定格総荷重 (t) | 作業半径 (m) | 定格総荷重 (t) | 作業半径 (m) | 定格総荷重 (t) | 作業半径 (m) | 定格総荷重 (t) |  |
| 82             | 2.8      | 1.80      | 3.6      | 1.80      | 5.1      | 1.80      | 6.2      | 1.50      | 7.1      | 1.15      | 7.4      | 1.20      |  |
| 80             | 3.3      | 1.80      | 4.1      | 1.80      | 5.5      | 1.80      | 6.7      | 1.50      | 7.4      | 1.15      | 7.8      | 1.20      |  |
| 78             | 3.8      | 1.80      | 4.6      | 1.80      | 6.0      | 1.80      | 7.1      | 1.50      | 7.8      | 1.15      | 8.1      | 1.20      |  |
| 74             | 4.8      | 1.80      | 5.6      | 1.80      | 6.9      | 1.40      | 7.9      | 1.10      | 8.5      | 1.00      |          |           |  |
| 72             | 5.3      | 1.80      | 6.0      | 1.70      | 7.3      | 1.20      | 8.3      | 0.95      | 8.8      | 0.85      |          |           |  |
| 70             | 5.7      | 1.80      | 6.5      | 1.40      | 7.8      | 1.00      | 8.7      | 0.80      | 9.1      | 0.75      |          |           |  |
| 67             | 6.4      | 1.30      | 7.2      | 1.05      | 8.4      | 0.80      | 9.2      | 0.65      | 9.6      | 0.60      |          |           |  |
| 65             | 6.9      | 1.10      | 7.6      | 0.90      | 8.8      | 0.70      | 9.5      | 0.55      | 9.9      | 0.50      |          |           |  |
| 62             | 7.6      | 0.85      | 8.3      | 0.70      | 9.3      | 0.50      | 10.0     | 0.45      |          |           |          |           |  |
| 60             | 8.0      | 0.70      | 8.7      | 0.60      | 9.7      | 0.40      |          |           |          |           |          |           |  |
| 57             | 8.6      | 0.50      | 9.3      | 0.45      | 10.2     | 0.30      |          |           |          |           |          |           |  |
| 55             | 9.0      | 0.40      | 9.6      | 0.35      |          |           |          |           |          |           |          |           |  |
| A(°)           | 45~82    |           | 50~82    |           |          |           | 60~82    |           | 75~82    |           |          |           |  |

| 8.7mブーム+8.9mジブ |          |           |          |           |          |           |          |           |          |           |          |           |  |
|----------------|----------|-----------|----------|-----------|----------|-----------|----------|-----------|----------|-----------|----------|-----------|--|
| ジブオフセット        | 7°       |           | 15°      |           | 30°      |           | 45°      |           | 60°      |           | 75°      |           |  |
| ブーム角度 (°)      | 作業半径 (m) | 定格総荷重 (t) | 作業半径 (m) | 定格総荷重 (t) | 作業半径 (m) | 定格総荷重 (t) | 作業半径 (m) | 定格総荷重 (t) | 作業半径 (m) | 定格総荷重 (t) | 作業半径 (m) | 定格総荷重 (t) |  |
| 82             | 3.4      | 1.20      | 4.6      | 1.20      | 6.6      | 1.20      | 8.2      | 1.00      | 9.3      | 0.85      | 9.8      | 0.90      |  |
| 80             | 4.0      | 1.20      | 5.2      | 1.20      | 7.1      | 1.20      | 8.7      | 1.00      | 9.7      | 0.85      | 10.2     | 0.90      |  |
| 78             | 4.6      | 1.20      | 5.7      | 1.20      | 7.7      | 1.20      | 9.2      | 1.00      | 10.1     | 0.80      |          |           |  |
| 74             | 5.8      | 1.20      | 6.8      | 1.20      | 8.7      | 0.95      | 10.0     | 0.75      | 10.8     | 0.60      |          |           |  |
| 72             | 6.3      | 1.20      | 7.4      | 1.20      | 9.2      | 0.80      | 10.5     | 0.63      | 11.2     | 0.52      |          |           |  |
| 70             | 6.9      | 1.00      | 7.9      | 1.00      | 9.6      | 0.70      | 10.9     | 0.53      | 11.5     | 0.45      |          |           |  |
| 67             | 7.7      | 0.85      | 8.7      | 0.80      | 10.3     | 0.55      | 11.5     | 0.40      | 12.0     | 0.35      |          |           |  |
| 65             | 8.2      | 0.75      | 9.2      | 0.65      | 10.8     | 0.45      | 11.8     | 0.33      |          |           |          |           |  |
| 62             | 9.0      | 0.60      | 9.9      | 0.45      | 11.4     | 0.30      |          |           |          |           |          |           |  |
| 60             | 9.5      | 0.45      | 10.4     | 0.35      | 11.8     | 0.23      |          |           |          |           |          |           |  |
| 57             | 10.2     | 0.30      | 11.1     | 0.23      |          |           |          |           |          |           |          |           |  |
| A(°)           | 50~82    |           | 52~82    |           |          |           | 57~82    |           | 60~82    |           | 75~82    |           |  |

| 8.7mブーム+13.6mジブ |          |           |          |           |          |           |          |           |          |           |          |           |  |
|-----------------|----------|-----------|----------|-----------|----------|-----------|----------|-----------|----------|-----------|----------|-----------|--|
| ジブオフセット         | 7°       |           | 15°      |           | 30°      |           | 45°      |           | 60°      |           | 75°      |           |  |
| ブーム角度 (°)       | 作業半径 (m) | 定格総荷重 (t) | 作業半径 (m) | 定格総荷重 (t) | 作業半径 (m) | 定格総荷重 (t) | 作業半径 (m) | 定格総荷重 (t) | 作業半径 (m) | 定格総荷重 (t) | 作業半径 (m) | 定格総荷重 (t) |  |
| 82              | 4.8      | 0.70      | 6.5      | 0.70      | 9.6      | 0.70      | 12.1     | 0.60      |          |           |          |           |  |
| 80              | 5.5      | 0.70      | 7.3      | 0.70      | 10.3     | 0.70      | 12.6     | 0.60      |          |           |          |           |  |
| 78              | 6.3      | 0.70      | 8.0      | 0.70      | 10.9     | 0.70      | 13.2     | 0.60      |          |           |          |           |  |
| 74              | 7.7      | 0.70      | 9.4      | 0.70      | 12.2     | 0.57      |          |           |          |           |          |           |  |
| 72              | 8.4      | 0.63      | 10.1     | 0.70      | 12.8     | 0.50      |          |           |          |           |          |           |  |
| 70              | 9.1      | 0.53      | 10.7     | 0.62      |          |           |          |           |          |           |          |           |  |
| 67              | 10.2     | 0.43      | 11.7     | 0.45      |          |           |          |           |          |           |          |           |  |
| 65              | 10.8     | 0.35      |          |           |          |           |          |           |          |           |          |           |  |
| 62              | 11.8     | 0.30      |          |           |          |           |          |           |          |           |          |           |  |
| A(°)            | 55~82    |           | 57~82    |           |          |           | 60~82    |           |          |           |          |           |  |

| 8.7mブーム+15.9mジブ |          |           |          |           |          |           |          |           |          |           |          |           |
|-----------------|----------|-----------|----------|-----------|----------|-----------|----------|-----------|----------|-----------|----------|-----------|
| ジブオフセット         | 7°       |           | 15°      |           | 30°      |           | 45°      |           | 60°      |           | 75°      |           |
| ブーム角度 (°)       | 作業半径 (m) | 定格総荷重 (t) | 作業半径 (m) | 定格総荷重 (t) | 作業半径 (m) | 定格総荷重 (t) | 作業半径 (m) | 定格総荷重 (t) | 作業半径 (m) | 定格総荷重 (t) | 作業半径 (m) | 定格総荷重 (t) |
| 82              | 5.5      | 0.65      | 7.5      | 0.65      | 11.1     | 0.40      | 13.9     | 0.30      |          |           |          |           |
| 80              | 6.3      | 0.65      | 8.3      | 0.65      | 11.8     | 0.40      | 14.5     | 0.30      |          |           |          |           |
| 78              | 7.1      | 0.65      | 9.1      | 0.65      | 12.5     | 0.40      | 15.1     | 0.30      |          |           |          |           |
| 74              | 8.7      | 0.60      | 10.6     | 0.56      | 13.9     | 0.38      | 16.3     | 0.30      |          |           |          |           |
| 72              | 9.5      | 0.50      | 11.4     | 0.53      | 14.5     | 0.35      | 16.8     | 0.30      |          |           |          |           |
| 70              | 10.3     | 0.40      | 12.1     | 0.50      | 15.2     | 0.30      |          |           |          |           |          |           |
| 67              | 11.4     | 0.33      | 13.2     | 0.37      |          |           |          |           |          |           |          |           |
| 65              | 12.2     | 0.29      | 13.9     | 0.30      |          |           |          |           |          |           |          |           |
| 62              | 13.2     | 0.24      |          |           |          |           |          |           |          |           |          |           |
| A(°)            | 55~82    |           | 57~82    |           | 62~82    |           | 70~82    |           |          |           |          |           |

A: ブーム角度の範囲 (無負荷時)

| 5.5mブーム+4.1mジブ |          |           |          |           |          |           |          |           |          |           |          |           |
|----------------|----------|-----------|----------|-----------|----------|-----------|----------|-----------|----------|-----------|----------|-----------|
| ジブオフセット        | ※7°      |           | ※15°     |           | 30°      |           | 45°      |           | 60°      |           | 75°      |           |
| ブーム角度 (°)      | 作業半径 (m) | 定格総荷重 (t) | 作業半径 (m) | 定格総荷重 (t) | 作業半径 (m) | 定格総荷重 (t) | 作業半径 (m) | 定格総荷重 (t) | 作業半径 (m) | 定格総荷重 (t) | 作業半径 (m) | 定格総荷重 (t) |
| 82             | 1.8      | 1.80      | 2.5      | 1.80      | 3.0      | 1.80      | 3.8      | 1.80      | 4.3      | 1.80      | 4.6      | 1.80      |
| 80             | 2.2      | 1.80      | 2.8      | 1.80      | 3.3      | 1.80      | 4.0      | 1.80      | 4.5      | 1.80      | 4.8      | 1.80      |
| 78             | 2.6      | 1.80      | 3.2      | 1.80      | 3.6      | 1.80      | 4.3      | 1.80      | 4.8      | 1.80      | 4.9      | 1.80      |
| 74             | 3.3      | 1.80      | 3.9      | 1.80      | 4.2      | 1.80      | 4.8      | 1.80      | 5.2      | 1.80      |          |           |
| 72             | 3.6      | 1.80      | 4.2      | 1.80      | 4.5      | 1.80      | 5.1      | 1.80      | 5.4      | 1.80      |          |           |
| 70             | 3.9      | 1.80      | 4.5      | 1.80      | 4.7      | 1.80      | 5.3      | 1.80      | 5.6      | 1.80      |          |           |
| 67             | 4.4      | 1.70      | 4.9      | 1.75      | 5.1      | 1.80      | 5.6      | 1.80      | 5.9      | 1.80      |          |           |
| 65             | 4.7      | 1.65      | 5.2      | 1.70      | 5.4      | 1.80      | 5.8      | 1.80      | 6.1      | 1.80      |          |           |
| 62             | 5.2      | 1.60      | 5.7      | 1.65      | 5.7      | 1.80      | 6.1      | 1.70      |          |           |          |           |
| 60             | 5.5      | 1.55      | 6.0      | 1.65      | 5.9      | 1.80      | 6.3      | 1.60      |          |           |          |           |
| 57             | 5.9      | 1.50      | 6.4      | 1.55      | 6.3      | 1.55      | 6.6      | 1.45      |          |           |          |           |
| 55             | 6.1      | 1.45      | 6.6      | 1.45      | 6.5      | 1.45      | 6.8      | 1.35      |          |           |          |           |
| 52             | 6.5      | 1.30      | 7.0      | 1.25      | 6.8      | 1.30      | 7.0      | 1.20      |          |           |          |           |
| 50             | 6.8      | 1.20      |          |           | 6.9      | 1.20      |          |           |          |           |          |           |
| A(°)           | 7~82     |           | 15~82    |           | 30~82    |           | 45~82    |           | 60~82    |           | 75~82    |           |

| 5.5mブーム+6.5mジブ |          |           |          |           |          |           |          |           |          |           |          |           |
|----------------|----------|-----------|----------|-----------|----------|-----------|----------|-----------|----------|-----------|----------|-----------|
| ジブオフセット        | 7°       |           | 15°      |           | 30°      |           | 45°      |           | 60°      |           | 75°      |           |
| ブーム角度 (°)      | 作業半径 (m) | 定格総荷重 (t) | 作業半径 (m) | 定格総荷重 (t) | 作業半径 (m) | 定格総荷重 (t) | 作業半径 (m) | 定格総荷重 (t) | 作業半径 (m) | 定格総荷重 (t) | 作業半径 (m) | 定格総荷重 (t) |
| 82             | 2.3      | 1.80      | 3.1      | 1.80      | 4.6      | 1.80      | 5.8      | 1.80      | 6.6      | 1.70      | 7.0      | 1.45      |
| 80             | 2.7      | 1.80      | 3.5      | 1.80      | 4.9      | 1.80      | 6.1      | 1.80      | 6.8      | 1.70      | 7.2      | 1.45      |
| 78             | 3.1      | 1.80      | 3.9      | 1.80      | 5.3      | 1.80      | 6.4      | 1.80      | 7.1      | 1.70      | 7.4      | 1.45      |
| 74             | 3.9      | 1.80      | 4.6      | 1.80      | 6.0      | 1.80      | 7.0      | 1.60      | 7.6      | 1.40      |          |           |
| 72             | 4.2      | 1.80      | 5.0      | 1.80      | 6.3      | 1.70      | 7.3      | 1.50      | 7.8      | 1.30      |          |           |
| 70             | 4.6      | 1.80      | 5.4      | 1.80      | 6.6      | 1.60      | 7.5      | 1.35      | 8.0      | 1.20      |          |           |
| 67             | 5.2      | 1.50      | 5.9      | 1.65      | 7.1      | 1.45      | 7.9      | 1.20      |          |           |          |           |
| 65             | 5.5      | 1.35      | 6.2      | 1.55      | 7.4      | 1.30      | 8.2      | 1.10      |          |           |          |           |
| 62             | 6.0      | 1.20      | 6.7      | 1.45      | 7.8      | 1.15      | 8.5      | 0.98      |          |           |          |           |
| 60             | 6.4      | 1.10      | 7.0      | 1.35      | 8.1      | 1.00      | 8.7      | 0.90      |          |           |          |           |
| 57             | 6.9      | 0.97      | 7.5      | 1.15      | 8.5      | 0.90      | 9.0      | 0.80      |          |           |          |           |
| 55             | 7.2      | 0.90      | 7.8      | 1.00      | 8.7      | 0.85      |          |           |          |           |          |           |
| 52             | 7.9      | 0.80      | 8.2      | 0.85      | 9.0      | 0.75      |          |           |          |           |          |           |
| 50             |          |           | 8.5      | 0.80      | 9.3      | 0.70      |          |           |          |           |          |           |
| A(°)           | 7~82     |           | 15~82    |           | 30~82    |           | 45~82    |           | 60~82    |           | 75~82    |           |

| 5.5mブーム+8.9mジブ |          |           |          |           |          |           |          |           |          |           |          |           |
|----------------|----------|-----------|----------|-----------|----------|-----------|----------|-----------|----------|-----------|----------|-----------|
| ジブオフセット        | 7°       |           | 15°      |           | 30°      |           | 45°      |           | 60°      |           | 75°      |           |
| ブーム角度 (°)      | 作業半径 (m) | 定格総荷重 (t) | 作業半径 (m) | 定格総荷重 (t) | 作業半径 (m) | 定格総荷重 (t) | 作業半径 (m) | 定格総荷重 (t) | 作業半径 (m) | 定格総荷重 (t) | 作業半径 (m) | 定格総荷重 (t) |
| 82             | 3.0      | 1.20      | 4.1      | 1.20      | 6.1      | 1.20      | 7.7      | 1.20      | 8.8      | 1.20      | 9.3      | 0.90      |
| 80             | 3.4      | 1.20      | 4.6      | 1.20      | 6.5      | 1.20      | 8.1      | 1.20      | 9.1      | 1.20      | 9.6      | 0.90      |
| 78             | 3.9      | 1.20      | 5.0      | 1.20      | 6.9      | 1.20      | 8.4      | 1.20      | 9.4      | 1.10      |          |           |
| 74             | 4.8      | 1.20      | 5.9      | 1.20      | 7.7      | 1.20      | 9.1      | 1.05      | 9.9      | 0.90      |          |           |
| 72             | 5.3      | 1.20      | 6.4      | 1.20      | 8.1      | 1.20      | 9.4      | 0.95      | 10.2     | 0.85      |          |           |
| 70             | 5.8      | 1.05      | 6.8      | 1.15      | 8.5      | 1.10      | 9.7      | 0.85      | 10.4     | 0.80      |          |           |
| 67             | 6.4      | 0.90      | 7.4      | 1.05      | 9.0      | 1.00      | 10.2     | 0.75      | 10.7     | 0.70      |          |           |
| 65             | 6.8      | 0.78      | 7.8      | 0.97      | 9.4      | 0.90      | 10.5     | 0.70      | 10.9     | 0.65      |          |           |
| 62             | 7.5      | 0.68      | 8.4      | 0.85      | 9.9      | 0.80      | 10.8     | 0.65      | 11.2     | 0.55      |          |           |
| 60             | 7.9      | 0.63      | 8.8      | 0.80      | 10.2     | 0.70      | 11.1     | 0.60      |          |           |          |           |
| 57             | 8.4      | 0.53      | 9.3      | 0.72      | 10.6     | 0.60      | 11.4     | 0.55      |          |           |          |           |
| 55             | 8.8      | 0.48      | 9.7      | 0.68      | 10.9     | 0.55      | 11.6     | 0.50      |          |           |          |           |
| 52             | 9.4      | 0.42      | 10.1     | 0.62      | 11.3     | 0.50      | 11.9     | 0.45      |          |           |          |           |
| 50             | 9.7      | 0.38      | 10.5     | 0.55      | 11.5     | 0.45      | 12.0     | 0.40      |          |           |          |           |
| A(°)           | 30~82    |           | 25~82    |           | 30~82    |           | 45~82    |           | 60~82    |           | 75~82    |           |

| 5.5mブーム+13.6mジブ |          |           |          |           |          |           |          |           |          |           |          |           |
|-----------------|----------|-----------|----------|-----------|----------|-----------|----------|-----------|----------|-----------|----------|-----------|
| ジブオフセット         | 7°       |           | 15°      |           | 30°      |           | 45°      |           | 60°      |           | 75°      |           |
| ブーム角度 (°)       | 作業半径 (m) | 定格総荷重 (t) | 作業半径 (m) | 定格総荷重 (t) | 作業半径 (m) | 定格総荷重 (t) | 作業半径 (m) | 定格総荷重 (t) | 作業半径 (m) | 定格総荷重 (t) | 作業半径 (m) | 定格総荷重 (t) |
| 82              | 4.3      | 0.70      | 6.0      | 0.70      | 9.1      | 0.70      | 11.6     | 0.68      |          |           |          |           |
| 80              | 4.9      | 0.70      | 6.7      | 0.70      | 9.7      | 0.70      | 12.0     | 0.68      |          |           |          |           |
| 78              | 5.6      | 0.70      | 7.3      | 0.70      | 10.2     | 0.70      | 12.5     | 0.68      |          |           |          |           |
| 74              | 6.8      | 0.70      | 8.4      | 0.70      | 11.2     | 0.70      | 13.3     | 0.60      |          |           |          |           |
| 72              | 7.4      | 0.65      | 9.0      | 0.70      | 11.7     | 0.70      | 13.7     | 0.54      |          |           |          |           |
| 70              | 8.0      | 0.55      | 9.6      | 0.65      | 12.2     | 0.70      | 14.1     | 0.48      |          |           |          |           |
| 67              | 8.9      | 0.45      | 10.4     | 0.55      | 12.9     | 0.55      | 14.6     | 0.43      |          |           |          |           |
| 65              | 9.4      | 0.40      | 10.9     | 0.50      | 13.3     | 0.50      | 15.0     | 0.40      |          |           |          |           |
| 62              | 10.3     | 0.33      | 11.7     | 0.43      | 14.0     | 0.40      |          |           |          |           |          |           |
| 60              | 10.8     | 0.27      | 12.2     | 0.39      | 14.4     | 0.35      |          |           |          |           |          |           |
| 57              |          |           | 12.9     | 0.35      | 14.9     | 0.30      |          |           |          |           |          |           |
| A(°)            | 45~82    |           | 45~82    |           | 40~82    |           | 45~82    |           |          |           |          |           |

| 5.5mブーム+15.9mジブ |          |           |          |           |          |           |          |           |          |           |          |           |
|-----------------|----------|-----------|----------|-----------|----------|-----------|----------|-----------|----------|-----------|----------|-----------|
| ジブオフセット         | 7°       |           | 15°      |           | 30°      |           | 45°      |           | 60°      |           | 75°      |           |
| ブーム角度 (°)       | 作業半径 (m) | 定格総荷重 (t) | 作業半径 (m) | 定格総荷重 (t) | 作業半径 (m) | 定格総荷重 (t) | 作業半径 (m) | 定格総荷重 (t) | 作業半径 (m) | 定格総荷重 (t) | 作業半径 (m) | 定格総荷重 (t) |
| 82              | 5.0      | 0.65      | 7.0      | 0.65      | 10.6     | 0.40      | 13.4     | 0.30      |          |           |          |           |
| 80              | 5.7      | 0.65      | 7.7      | 0.65      | 11.2     | 0.40      | 13.9     | 0.30      |          |           |          |           |
| 78              | 6.4      | 0.65      | 8.4      | 0.65      | 11.8     | 0.40      | 14.4     | 0.30      |          |           |          |           |
| 74              | 7.8      | 0.55      | 9.7      | 0.56      | 12.9     | 0.38      | 15.4     | 0.30      |          |           |          |           |
| 72              | 8.5      | 0.50      | 10.4     | 0.53      | 13.5     | 0.37      | 15.8     | 0.29      |          |           |          |           |
| 70              | 9.1      | 0.43      | 11.0     | 0.50      | 14.0     | 0.36      | 16.2     | 0.29      |          |           |          |           |
| 67              | 10.1     | 0.35      | 11.9     | 0.45      | 14.8     | 0.34      | 16.8     | 0.28      |          |           |          |           |
| 65              | 10.8     | 0.30      | 12.5     | 0.40      |          |           |          |           |          |           |          |           |
| 62              | 11.7     | 0.25      | 13.4     | 0.33      |          |           |          |           |          |           |          |           |
| 60              |          |           | 13.9     | 0.30      |          |           |          |           |          |           |          |           |
| A(°)            | 52~82    |           | 55~82    |           | 55~82    |           | 65~82    |           |          |           |          |           |

A: ブーム角度の範囲 (無負荷時)

■ 定格総荷重表 [補巻作業] アウトリガ最小張出 (1.64m) 一側方

※は5.0mジブ状態を示します。

| 15.0mブーム+4.1mジブ |          |           |          |           |          |           |          |           |          |           |          |           |
|-----------------|----------|-----------|----------|-----------|----------|-----------|----------|-----------|----------|-----------|----------|-----------|
| ジブオフセット         | ※7°      |           | ※15°     |           | 30°      |           | 45°      |           | 60°      |           | 75°      |           |
| ブーム角度 (°)       | 作業半径 (m) | 定格総荷重 (t) | 作業半径 (m) | 定格総荷重 (t) | 作業半径 (m) | 定格総荷重 (t) | 作業半径 (m) | 定格総荷重 (t) | 作業半径 (m) | 定格総荷重 (t) | 作業半径 (m) | 定格総荷重 (t) |
| 82              | 3.3      | 1.55      | 4.0      | 1.30      | 4.6      | 1.05      | 5.4      | 0.65      | 5.9      | 0.35      | 6.1      | 0.35      |
| 80              | 4.0      | 1.30      | 4.7      | 1.05      | 5.3      | 0.85      | 6.0      | 0.65      | 6.4      | 0.35      | 6.6      | 0.35      |
| 78              | 4.8      | 0.85      | 5.3      | 0.65      | 5.9      | 0.55      |          |           | 7.0      | 0.35      |          |           |
| A(°)            | 74~82    |           |          |           |          |           | 75~82    |           |          |           |          |           |

| 15.0mブーム+6.5mジブ |          |           |          |           |          |           |          |           |          |           |          |           |
|-----------------|----------|-----------|----------|-----------|----------|-----------|----------|-----------|----------|-----------|----------|-----------|
| ジブオフセット         | 7°       |           | 15°      |           | 30°      |           | 45°      |           | 60°      |           | 75°      |           |
| ブーム角度 (°)       | 作業半径 (m) | 定格総荷重 (t) | 作業半径 (m) | 定格総荷重 (t) | 作業半径 (m) | 定格総荷重 (t) | 作業半径 (m) | 定格総荷重 (t) | 作業半径 (m) | 定格総荷重 (t) | 作業半径 (m) | 定格総荷重 (t) |
| 82              | 4.0      | 1.20      | 4.8      | 0.80      |          |           |          |           |          |           |          |           |
| 80              | 4.7      | 1.05      | 5.6      | 0.75      |          |           |          |           |          |           |          |           |
| 78              | 5.5      | 0.65      |          |           |          |           |          |           |          |           |          |           |
| A(°)            | 74~82    |           |          |           |          |           |          |           |          |           |          |           |

A: ブーム角度の範囲 (無負荷時)

補巻作業

■ 定格総荷重表 [補巻作業] アウトリガ最小張出 (1.64m) 一側方

※は5.0mジブ状態を示します。

| 11.8mブーム+4.1mジブ |          |           |          |           |          |           |          |           |          |           |          |           |
|-----------------|----------|-----------|----------|-----------|----------|-----------|----------|-----------|----------|-----------|----------|-----------|
| ジブオフセット         | ※7°      |           | ※15°     |           | 30°      |           | 45°      |           | 60°      |           | 75°      |           |
| ブーム角度 (°)       | 作業半径 (m) | 定格総荷重 (t) | 作業半径 (m) | 定格総荷重 (t) | 作業半径 (m) | 定格総荷重 (t) | 作業半径 (m) | 定格総荷重 (t) | 作業半径 (m) | 定格総荷重 (t) | 作業半径 (m) | 定格総荷重 (t) |
| 82              | 2.8      | 1.70      | 3.4      | 1.65      | 4.0      | 1.40      | 4.8      | 1.20      | 5.3      | 1.00      | 5.5      | 0.75      |
| 80              | 3.4      | 1.70      | 3.9      | 1.60      | 4.5      | 1.40      | 5.3      | 1.10      | 5.7      | 0.90      | 5.9      | 0.75      |
| 78              | 3.9      | 1.55      | 4.6      | 1.20      | 5.1      | 1.00      | 5.7      | 0.80      | 6.2      | 0.70      |          |           |
| 74              | 5.1      | 0.80      | 5.7      | 0.55      | 6.0      | 0.50      |          |           |          |           |          |           |
| 72              | 5.6      | 0.50      | 6.1      | 0.40      |          |           |          |           |          |           |          |           |
| A(°)            | 70~82    |           | 67~82    |           | 72~82    |           | 74~82    |           | 74~82    |           | 75~82    |           |

| 11.8mブーム+6.5mジブ |          |           |          |           |          |           |          |           |          |           |          |           |
|-----------------|----------|-----------|----------|-----------|----------|-----------|----------|-----------|----------|-----------|----------|-----------|
| ジブオフセット         | 7°       |           | 15°      |           | 30°      |           | 45°      |           | 60°      |           | 75°      |           |
| ブーム角度 (°)       | 作業半径 (m) | 定格総荷重 (t) | 作業半径 (m) | 定格総荷重 (t) | 作業半径 (m) | 定格総荷重 (t) | 作業半径 (m) | 定格総荷重 (t) | 作業半径 (m) | 定格総荷重 (t) | 作業半径 (m) | 定格総荷重 (t) |
| 82              | 3.3      | 1.60      | 4.2      | 1.45      | 5.6      | 0.85      | 6.8      | 0.65      |          |           |          |           |
| 80              | 4.0      | 1.60      | 4.8      | 1.30      | 6.2      | 0.80      |          |           |          |           |          |           |
| 78              | 4.6      | 1.15      | 5.4      | 0.80      | 6.8      | 0.50      |          |           |          |           |          |           |
| 74              | 5.8      | 0.50      |          |           |          |           |          |           |          |           |          |           |
| A(°)            | 70~82    |           | 72~82    |           | 74~82    |           |          |           |          |           |          |           |

| 11.8mブーム+8.9mジブ |          |           |          |           |          |           |          |           |          |           |          |           |
|-----------------|----------|-----------|----------|-----------|----------|-----------|----------|-----------|----------|-----------|----------|-----------|
| ジブオフセット         | 7°       |           | 15°      |           | 30°      |           | 45°      |           | 60°      |           | 75°      |           |
| ブーム角度 (°)       | 作業半径 (m) | 定格総荷重 (t) | 作業半径 (m) | 定格総荷重 (t) | 作業半径 (m) | 定格総荷重 (t) | 作業半径 (m) | 定格総荷重 (t) | 作業半径 (m) | 定格総荷重 (t) | 作業半径 (m) | 定格総荷重 (t) |
| 82              | 4.0      | 1.20      | 5.2      | 1.05      |          |           |          |           |          |           |          |           |
| 80              | 4.7      | 1.20      | 5.9      | 0.85      |          |           |          |           |          |           |          |           |
| 78              | 5.4      | 0.90      | 6.5      | 0.60      |          |           |          |           |          |           |          |           |
| 74              | 6.8      | 0.35      |          |           |          |           |          |           |          |           |          |           |
| A(°)            | 72~82    |           |          |           |          |           |          |           |          |           |          |           |

| 11.8mブーム+13.6mジブ |          |           |          |           |          |           |          |           |          |           |          |           |
|------------------|----------|-----------|----------|-----------|----------|-----------|----------|-----------|----------|-----------|----------|-----------|
| ジブオフセット          | 7°       |           | 15°      |           | 30°      |           | 45°      |           | 60°      |           | 75°      |           |
| ブーム角度 (°)        | 作業半径 (m) | 定格総荷重 (t) | 作業半径 (m) | 定格総荷重 (t) | 作業半径 (m) | 定格総荷重 (t) | 作業半径 (m) | 定格総荷重 (t) | 作業半径 (m) | 定格総荷重 (t) | 作業半径 (m) | 定格総荷重 (t) |
| 82               | 5.4      | 0.70      | 7.2      | 0.50      |          |           |          |           |          |           |          |           |
| 80               | 6.2      | 0.70      | 8.0      | 0.50      |          |           |          |           |          |           |          |           |
| 78               | 7.1      | 0.60      |          |           |          |           |          |           |          |           |          |           |
| A(°)             | 72~82    |           | 74~82    |           |          |           |          |           |          |           |          |           |

| 11.8mブーム+15.9mジブ |          |           |          |           |          |           |          |           |          |           |          |           |
|------------------|----------|-----------|----------|-----------|----------|-----------|----------|-----------|----------|-----------|----------|-----------|
| ジブオフセット          | 7°       |           | 15°      |           | 30°      |           | 45°      |           | 60°      |           | 75°      |           |
| ブーム角度 (°)        | 作業半径 (m) | 定格総荷重 (t) | 作業半径 (m) | 定格総荷重 (t) | 作業半径 (m) | 定格総荷重 (t) | 作業半径 (m) | 定格総荷重 (t) | 作業半径 (m) | 定格総荷重 (t) | 作業半径 (m) | 定格総荷重 (t) |
| 82               | 6.1      | 0.65      | 8.1      | 0.40      |          |           |          |           |          |           |          |           |
| 80               | 7.0      | 0.65      | 9.0      | 0.40      |          |           |          |           |          |           |          |           |
| 78               | 7.9      | 0.45      |          |           |          |           |          |           |          |           |          |           |
| A(°)             | 74~82    |           |          |           |          |           |          |           |          |           |          |           |

A: ブーム角度の範囲 (無負荷時)

| 8.7mブーム+4.1mジブ |          |           |          |           |          |           |          |           |          |           |          |           |
|----------------|----------|-----------|----------|-----------|----------|-----------|----------|-----------|----------|-----------|----------|-----------|
| ジブオフセット        | ※7°      |           | ※15°     |           | 30°      |           | 45°      |           | 60°      |           | 75°      |           |
| ブーム角度 (°)      | 作業半径 (m) | 定格総荷重 (t) | 作業半径 (m) | 定格総荷重 (t) | 作業半径 (m) | 定格総荷重 (t) | 作業半径 (m) | 定格総荷重 (t) | 作業半径 (m) | 定格総荷重 (t) | 作業半径 (m) | 定格総荷重 (t) |
| 82             | 2.3      | 1.80      | 2.9      | 1.80      | 3.5      | 1.80      | 4.2      | 1.60      | 4.8      | 1.35      | 5.0      | 1.05      |
| 80             | 2.8      | 1.80      | 3.4      | 1.80      | 3.9      | 1.80      | 4.6      | 1.50      | 5.1      | 1.30      | 5.3      | 1.05      |
| 78             | 3.2      | 1.80      | 3.9      | 1.70      | 4.3      | 1.60      | 5.0      | 1.25      | 5.4      | 1.10      | 5.6      | 1.00      |
| 74             | 4.1      | 1.55      | 4.7      | 1.15      | 5.1      | 1.00      | 5.7      | 0.80      | 6.1      | 0.70      |          |           |
| 72             | 4.6      | 1.10      | 5.2      | 0.90      | 5.5      | 0.75      | 6.1      | 0.60      | 6.4      | 0.60      |          |           |
| 70             | 5.0      | 0.85      | 5.6      | 0.70      | 5.8      | 0.60      | 6.4      | 0.50      | 6.7      | 0.40      |          |           |
| 67             |          |           |          |           |          |           | 6.9      | 0.30      |          |           |          |           |
| A(°)           | 62~82    |           |          |           | 65~82    |           |          |           | 67~82    |           | 75~82    |           |

| 8.7mブーム+6.5mジブ |          |           |          |           |          |           |          |           |          |           |          |           |
|----------------|----------|-----------|----------|-----------|----------|-----------|----------|-----------|----------|-----------|----------|-----------|
| ジブオフセット        | 7°       |           | 15°      |           | 30°      |           | 45°      |           | 60°      |           | 75°      |           |
| ブーム角度 (°)      | 作業半径 (m) | 定格総荷重 (t) | 作業半径 (m) | 定格総荷重 (t) | 作業半径 (m) | 定格総荷重 (t) | 作業半径 (m) | 定格総荷重 (t) | 作業半径 (m) | 定格総荷重 (t) | 作業半径 (m) | 定格総荷重 (t) |
| 82             | 2.8      | 1.80      | 3.6      | 1.80      | 5.1      | 1.10      | 6.2      | 0.65      |          |           |          |           |
| 80             | 3.3      | 1.80      | 4.1      | 1.80      | 5.5      | 1.10      | 6.7      | 0.65      |          |           |          |           |
| 78             | 3.8      | 1.80      | 4.6      | 1.50      | 6.0      | 0.85      | 7.1      | 0.60      |          |           |          |           |
| 74             | 4.8      | 1.20      | 5.6      | 0.80      | 6.9      | 0.50      |          |           |          |           |          |           |
| 72             | 5.3      | 0.80      | 6.0      | 0.65      |          |           |          |           |          |           |          |           |
| 70             | 5.7      | 0.60      |          |           |          |           |          |           |          |           |          |           |
| A(°)           | 62~82    |           | 65~82    |           | 67~82    |           | 72~82    |           |          |           |          |           |

| 8.7mブーム+8.9mジブ |          |           |          |           |          |           |          |           |          |           |          |           |
|----------------|----------|-----------|----------|-----------|----------|-----------|----------|-----------|----------|-----------|----------|-----------|
| ジブオフセット        | 7°       |           | 15°      |           | 30°      |           | 45°      |           | 60°      |           | 75°      |           |
| ブーム角度 (°)      | 作業半径 (m) | 定格総荷重 (t) | 作業半径 (m) | 定格総荷重 (t) | 作業半径 (m) | 定格総荷重 (t) | 作業半径 (m) | 定格総荷重 (t) | 作業半径 (m) | 定格総荷重 (t) | 作業半径 (m) | 定格総荷重 (t) |
| 82             | 3.4      | 1.20      | 4.6      | 1.20      | 6.6      | 0.75      |          |           |          |           |          |           |
| 80             | 4.0      | 1.20      | 5.2      | 1.20      | 7.1      | 0.70      |          |           |          |           |          |           |
| 78             | 4.6      | 1.20      | 5.7      | 1.00      | 7.7      | 0.55      |          |           |          |           |          |           |
| 74             | 5.8      | 0.80      | 6.8      | 0.60      |          |           |          |           |          |           |          |           |
| 72             | 6.3      | 0.60      |          |           |          |           |          |           |          |           |          |           |
| 70             | 6.9      | 0.40      |          |           |          |           |          |           |          |           |          |           |
| A(°)           | 65~82    |           | 67~82    |           | 72~82    |           |          |           |          |           |          |           |

| 8.7mブーム+13.6mジブ |          |           |          |           |          |           |          |           |          |           |          |           |
|-----------------|----------|-----------|----------|-----------|----------|-----------|----------|-----------|----------|-----------|----------|-----------|
| ジブオフセット         | 7°       |           | 15°      |           | 30°      |           | 45°      |           | 60°      |           | 75°      |           |
| ブーム角度 (°)       | 作業半径 (m) | 定格総荷重 (t) | 作業半径 (m) | 定格総荷重 (t) | 作業半径 (m) | 定格総荷重 (t) | 作業半径 (m) | 定格総荷重 (t) | 作業半径 (m) | 定格総荷重 (t) | 作業半径 (m) | 定格総荷重 (t) |
| 82              | 4.8      | 0.70      | 6.5      | 0.70      |          |           |          |           |          |           |          |           |
| 80              | 5.5      | 0.70      | 7.3      | 0.70      |          |           |          |           |          |           |          |           |
| 78              | 6.3      | 0.70      | 8.0      | 0.55      |          |           |          |           |          |           |          |           |
| 74              | 7.7      | 0.45      |          |           |          |           |          |           |          |           |          |           |
| A(°)            | 67~82    |           | 72~82    |           |          |           |          |           |          |           |          |           |

| 8.7mブーム+15.9mジブ |          |           |          |           |          |           |          |           |          |           |          |           |
|-----------------|----------|-----------|----------|-----------|----------|-----------|----------|-----------|----------|-----------|----------|-----------|
| ジブオフセット         | 7°       |           | 15°      |           | 30°      |           | 45°      |           | 60°      |           | 75°      |           |
| ブーム角度 (°)       | 作業半径 (m) | 定格総荷重 (t) | 作業半径 (m) | 定格総荷重 (t) | 作業半径 (m) | 定格総荷重 (t) | 作業半径 (m) | 定格総荷重 (t) | 作業半径 (m) | 定格総荷重 (t) | 作業半径 (m) | 定格総荷重 (t) |
| 82              | 5.5      | 0.65      | 7.5      | 0.65      |          |           |          |           |          |           |          |           |
| 80              | 6.3      | 0.65      | 8.3      | 0.65      |          |           |          |           |          |           |          |           |
| 78              | 7.1      | 0.65      | 9.1      | 0.50      |          |           |          |           |          |           |          |           |
| 74              | 8.7      | 0.40      |          |           |          |           |          |           |          |           |          |           |
| A(°)            | 70~82    |           | 72~82    |           |          |           |          |           |          |           |          |           |

A: ブーム角度の範囲 (無負荷時)

| ジブオフセット   | ※7°      |           | ※15°     |           | 30°      |           | 45°      |           | 60°      |           | 75°      |           |
|-----------|----------|-----------|----------|-----------|----------|-----------|----------|-----------|----------|-----------|----------|-----------|
| ブーム角度 (°) | 作業半径 (m) | 定格総荷重 (t) | 作業半径 (m) | 定格総荷重 (t) | 作業半径 (m) | 定格総荷重 (t) | 作業半径 (m) | 定格総荷重 (t) | 作業半径 (m) | 定格総荷重 (t) | 作業半径 (m) | 定格総荷重 (t) |
| 82        | 1.8      | 1.80      | 2.5      | 1.80      | 3.0      | 1.80      | 3.8      | 1.80      | 4.3      | 1.70      | 4.6      | 1.40      |
| 80        | 2.2      | 1.80      | 2.8      | 1.80      | 3.3      | 1.80      | 4.0      | 1.80      | 4.5      | 1.70      | 4.8      | 1.40      |
| 78        | 2.6      | 1.80      | 3.2      | 1.80      | 3.6      | 1.80      | 4.3      | 1.80      | 4.8      | 1.55      | 4.9      | 1.40      |
| 74        | 3.3      | 1.80      | 3.9      | 1.75      | 4.2      | 1.80      | 4.8      | 1.40      | 5.2      | 1.30      |          |           |
| 72        | 3.6      | 1.75      | 4.2      | 1.60      | 4.5      | 1.55      | 5.1      | 1.30      | 5.4      | 1.15      |          |           |
| 70        | 3.9      | 1.65      | 4.5      | 1.45      | 4.7      | 1.35      | 5.3      | 1.10      | 5.6      | 1.00      |          |           |
| 67        | 4.4      | 1.50      | 4.9      | 1.15      | 5.1      | 1.15      | 5.6      | 0.90      | 5.9      | 0.85      |          |           |
| 65        | 4.7      | 1.20      | 5.2      | 1.05      | 5.4      | 1.00      | 5.8      | 0.80      | 6.1      | 0.75      |          |           |
| 62        | 5.2      | 0.95      | 5.7      | 0.80      | 5.7      | 0.80      | 6.1      | 0.70      |          |           |          |           |
| 60        | 5.5      | 0.80      | 6.0      | 0.70      | 5.9      | 0.70      | 6.3      | 0.60      |          |           |          |           |
| 57        | 5.9      | 0.65      |          |           | 6.3      | 0.60      | 6.6      | 0.50      |          |           |          |           |
| 55        | 6.1      | 0.60      |          |           | 6.5      | 0.50      | 6.8      | 0.45      |          |           |          |           |
| 52        |          |           |          |           | 6.8      | 0.40      | 7.0      | 0.35      |          |           |          |           |
| 50        |          |           |          |           | 6.9      | 0.35      |          |           |          |           |          |           |
| A(°)      | 50~82    |           | 40~82    |           | 45~82    |           | 50~82    |           | 60~82    |           | 75~82    |           |

| ジブオフセット   | 7°       |           | 15°      |           | 30°      |           | 45°      |           | 60°      |           | 75°      |           |
|-----------|----------|-----------|----------|-----------|----------|-----------|----------|-----------|----------|-----------|----------|-----------|
| ブーム角度 (°) | 作業半径 (m) | 定格総荷重 (t) | 作業半径 (m) | 定格総荷重 (t) | 作業半径 (m) | 定格総荷重 (t) | 作業半径 (m) | 定格総荷重 (t) | 作業半径 (m) | 定格総荷重 (t) | 作業半径 (m) | 定格総荷重 (t) |
| 82        | 2.3      | 1.80      | 3.1      | 1.80      | 4.6      | 1.50      | 5.8      | 1.10      | 6.6      | 0.80      | 7.0      | 0.65      |
| 80        | 2.7      | 1.80      | 3.5      | 1.80      | 4.9      | 1.50      | 6.1      | 1.10      | 6.8      | 0.80      | 7.2      | 0.65      |
| 78        | 3.1      | 1.80      | 3.9      | 1.80      | 5.3      | 1.30      | 6.4      | 0.95      | 7.1      | 0.80      | 7.4      | 0.65      |
| 74        | 3.9      | 1.80      | 4.6      | 1.55      | 6.0      | 0.95      | 7.0      | 0.70      | 7.6      | 0.60      |          |           |
| 72        | 4.2      | 1.65      | 5.0      | 1.30      | 6.3      | 0.85      | 7.3      | 0.65      | 7.8      | 0.50      |          |           |
| 70        | 4.6      | 1.35      | 5.4      | 1.10      | 6.6      | 0.75      | 7.5      | 0.55      | 8.0      | 0.45      |          |           |
| 67        | 5.2      | 1.05      | 5.9      | 0.80      | 7.1      | 0.60      | 7.9      | 0.40      |          |           |          |           |
| 65        | 5.5      | 0.90      | 6.2      | 0.70      |          |           |          |           |          |           |          |           |
| 62        | 6.0      | 0.70      | 6.7      | 0.55      |          |           |          |           |          |           |          |           |
| 60        | 6.4      | 0.55      | 7.0      | 0.45      |          |           |          |           |          |           |          |           |
| 57        | 6.9      | 0.40      |          |           |          |           |          |           |          |           |          |           |
| A(°)      | 55~82    |           | 57~82    |           | 60~82    |           | 65~82    |           | 75~82    |           |          |           |

| ジブオフセット   | 7°       |           | 15°      |           | 30°      |           | 45°      |           | 60°      |           | 75°      |           |
|-----------|----------|-----------|----------|-----------|----------|-----------|----------|-----------|----------|-----------|----------|-----------|
| ブーム角度 (°) | 作業半径 (m) | 定格総荷重 (t) | 作業半径 (m) | 定格総荷重 (t) | 作業半径 (m) | 定格総荷重 (t) | 作業半径 (m) | 定格総荷重 (t) | 作業半径 (m) | 定格総荷重 (t) | 作業半径 (m) | 定格総荷重 (t) |
| 82        | 3.0      | 1.20      | 4.1      | 1.20      | 6.1      | 0.80      | 7.7      | 0.70      | 8.8      | 0.50      | 9.3      | 0.35      |
| 80        | 3.4      | 1.20      | 4.6      | 1.20      | 6.5      | 0.80      | 8.1      | 0.70      | 9.1      | 0.50      | 9.6      | 0.35      |
| 78        | 3.9      | 1.20      | 5.0      | 1.20      | 6.9      | 0.80      | 8.4      | 0.60      |          |           |          |           |
| 74        | 4.8      | 1.20      | 5.9      | 1.20      | 7.7      | 0.65      | 9.1      | 0.45      |          |           |          |           |
| 72        | 5.3      | 1.20      | 6.4      | 0.90      | 8.1      | 0.55      |          |           |          |           |          |           |
| 70        | 5.8      | 1.00      | 6.8      | 0.75      | 8.5      | 0.45      |          |           |          |           |          |           |
| 67        | 6.4      | 0.80      | 7.4      | 0.60      | 9.0      | 0.35      |          |           |          |           |          |           |
| 65        | 6.8      | 0.60      | 7.8      | 0.50      |          |           |          |           |          |           |          |           |
| 62        | 7.5      | 0.50      |          |           |          |           |          |           |          |           |          |           |
| 60        | 7.9      | 0.40      |          |           |          |           |          |           |          |           |          |           |
| A(°)      | 57~82    |           | 62~82    |           | 65~82    |           | 67~82    |           | 72~82    |           | 75~82    |           |

| ジブオフセット   | 7°       |           | 15°      |           | 30°      |           | 45°      |           | 60°      |           | 75°      |           |
|-----------|----------|-----------|----------|-----------|----------|-----------|----------|-----------|----------|-----------|----------|-----------|
| ブーム角度 (°) | 作業半径 (m) | 定格総荷重 (t) | 作業半径 (m) | 定格総荷重 (t) | 作業半径 (m) | 定格総荷重 (t) | 作業半径 (m) | 定格総荷重 (t) | 作業半径 (m) | 定格総荷重 (t) | 作業半径 (m) | 定格総荷重 (t) |
| 82        | 4.3      | 0.70      | 6.0      | 0.70      | 9.1      | 0.50      |          |           |          |           |          |           |
| 80        | 4.9      | 0.70      | 6.7      | 0.70      | 9.7      | 0.50      |          |           |          |           |          |           |
| 78        | 5.6      | 0.70      | 7.3      | 0.70      | 10.2     | 0.50      |          |           |          |           |          |           |
| 74        | 6.8      | 0.70      | 8.4      | 0.70      |          |           |          |           |          |           |          |           |
| 72        | 7.4      | 0.63      | 9.0      | 0.50      |          |           |          |           |          |           |          |           |
| 70        | 8.0      | 0.55      | 9.6      | 0.40      |          |           |          |           |          |           |          |           |
| 67        | 8.9      | 0.40      |          |           |          |           |          |           |          |           |          |           |
| 65        | 9.4      | 0.35      |          |           |          |           |          |           |          |           |          |           |
| A(°)      | 62~82    |           | 67~82    |           | 70~82    |           |          |           |          |           |          |           |

| ジブオフセット   | 7°       |           | 15°      |           | 30°      |           | 45°      |           | 60°      |           | 75°      |           |
|-----------|----------|-----------|----------|-----------|----------|-----------|----------|-----------|----------|-----------|----------|-----------|
| ブーム角度 (°) | 作業半径 (m) | 定格総荷重 (t) | 作業半径 (m) | 定格総荷重 (t) | 作業半径 (m) | 定格総荷重 (t) | 作業半径 (m) | 定格総荷重 (t) | 作業半径 (m) | 定格総荷重 (t) | 作業半径 (m) | 定格総荷重 (t) |
| 82        | 5.0      | 0.65      | 7.0      | 0.65      | 10.6     | 0.40      |          |           |          |           |          |           |
| 80        | 5.7      | 0.65      | 7.7      | 0.65      | 11.2     | 0.40      |          |           |          |           |          |           |
| 78        | 6.4      | 0.65      | 8.4      | 0.65      | 11.8     | 0.40      |          |           |          |           |          |           |
| 74        | 7.8      | 0.55      | 9.7      | 0.50      |          |           |          |           |          |           |          |           |
| 72        | 8.5      | 0.50      | 10.4     | 0.40      |          |           |          |           |          |           |          |           |
| 70        | 9.1      | 0.40      | 11.0     | 0.30      |          |           |          |           |          |           |          |           |
| A(°)      | 65~82    |           | 67~82    |           | 72~82    |           |          |           |          |           |          |           |

A: ブーム角度の範囲 (無負荷時)

(注意)

1. 定格総荷重は、水平堅土上においてクレーンを水平に設置した状態での値で、つり具と補巻フック質量 (25kg) を含んだ値です。太線より上はクレーンの強度によって定められ、下はクレーンの安定度によって定められています。
2. ブームの角度を基準にしてください。なお、作業半径は、ブームのたわみを含んだ参考値を示します。
3. 補巻作業におけるフックのワイヤー標準巻掛本数は1本です。
4. 側方域でのつり上げ性能は、アウトリガ張出幅によって異なります。張出幅に応じた性能で作業をしてください。また、前方・後方域でのつり上げ性能は「アウトリガ最大張出」の定格総荷重ですが、アウトリガ張出幅によってその前方・後方域の範囲(角度 a)が異なります。

| 張出幅   | 中間張出 (4.3m) | 中間張出 (3.5m) | 中間張出 (2.5m) | 最小張出 (1.64m) |
|-------|-------------|-------------|-------------|--------------|
| 角度 a° | 35          | 25          | 15          | 5            |

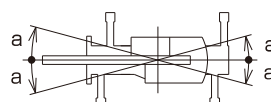

| 型式呼称    | 仕 様  | スペック番号          |
|---------|--|-----------------|
| GR-130F | 4.9t吊 4段ブーム 6段フルオートジブ H型アウトリガ、タイヤ 275/80R22.5 仕様 | GR-130F-1-00101 |
| GR-130F | 4.9t吊 4段ブーム 6段フルオートジブ H型アウトリガ、タイヤ 295/80R22.5 仕様 | GR-130F-1-00102 |

※お届けいたします製品は、改良などのため、この仕様書と相違する場合がありますのでご了承ください。